

Catsim[®]

Static Catenary-Elastic Analysis Software
from SeaSoft[®] Systems

User Manual

April, 2005

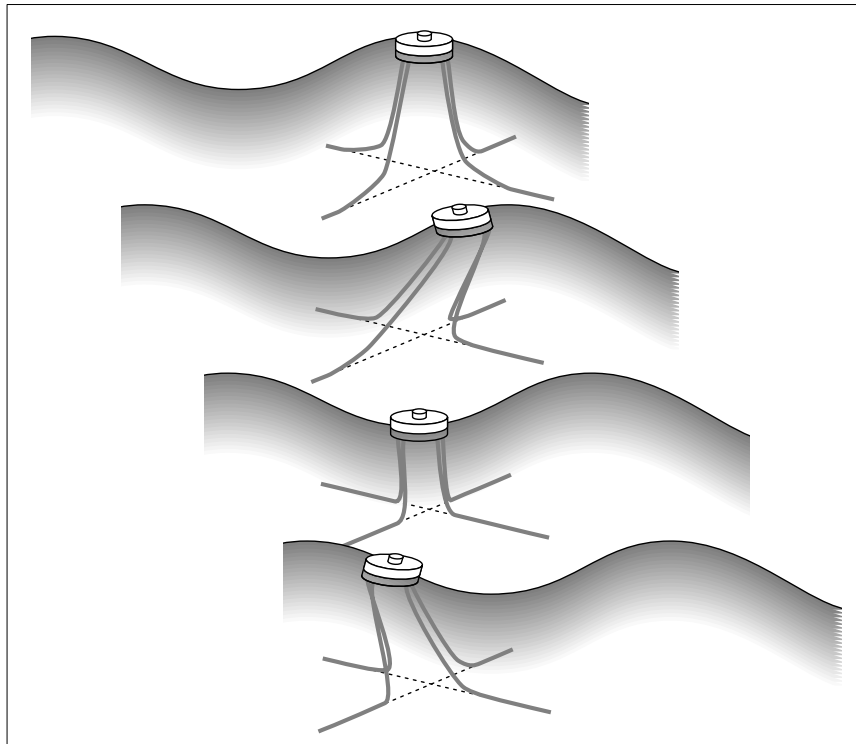

Catsim

Static Catenary-Elastic Analysis Software
from SeaSoft Systems

User Manual

Copyright © 1990-2005 by SeaSoft Systems

<http://www.seasoftsys.com>

Notice

The contents of this manual and the accompanying computer programs are provided on an "as is" basis without warranties of any kind, specific or implied. SeaSoft Systems and Richard J. Hartman, Ph.D., shall have no responsibility or liability for any loss or damage caused or alleged to be caused directly or indirectly by the use of this manual, the accompanying computer programs or any other materials or information provided in connection with the manual or programs.

About the SeaSoft Library

The SeaSoft family of software products for the offshore industry has been developed in response to a need for high quality, easy to use analytical tools for numerical simulation of the dynamic and static characteristics of a wide variety of offshore vessels and mooring structures.

The variety of computing platforms now used in engineering and naval architectural environments requires that offshore engineering software be easily transportable to a wide variety of computers (Macintosh, Unix, Windows, etc.) so that software tools can easily be moved to new computing facilities as the need arises. The SeaSoft program library was developed with these considerations in mind.

SeaSoft's products are capable, in most circumstances, of exceeding the physical modeling capabilities of older, operationally more complex codes while far surpassing them in terms of versatility and ease of use. Benchmark efforts by the DeepStar Committee (<http://www.deepstar.org>), using high-quality model test data as simulation quality arbiter, have shown unequivocally that the quality of the SeaSoft simulations surpasses all other available mooring tools, be they time-domain, frequency-domain or hybrid.

In the development of this suite of programs, the principal objectives have been (1) to deliver state of the art computational abilities to the offshore industry in packages that would permit their utilization by any technically trained individual with a need for the information, and (2) to insure that the quality and robustness of the underlying physical and analytical modeling are second to none.

The software is oriented specifically towards the practicing marine/offshore engineer and naval architect. In order to be of maximum utility to this audience, the software has been designed so that first-time or infrequent users can produce meaningful results.

Table of Contents

Chapter 1	<i>Introduction</i>	1
	Background.....	1
	Objectives.....	1
	Catsim-Statmoor Differences.....	1
	Support of Related Simulations	2
	Two-Vessel Problems: CALMsim.....	2
	Frequently Asked Questions (FAQ)	3
Chapter 2	<i>Program Package Contents</i>	4
	Program Files	4
	The User Interface.....	4
	User Manual Overview	4
	Automatic Backup of Input Files.....	5
Chapter 3	<i>Input Data Requirements</i>	6
	Data File Importation	6
	Importation of CALMsim Data Files.....	6
	Buoy-Along Analysis Considerations.....	7
	Data File Exportation.....	7
	Mooring System Data	7
	Treatment of Submerged Buoys and Clumped Weights.....	7
	Risers and Other Mooring-Type Structures.....	8
Chapter 4	<i>User Interface Description</i>	9
	General Editing Information	9
	Editor Screen Images	10
Chapter 5	<i>Output Stream Description</i>	38
	Output Description by Output Section.....	38
	The "CATOUT.stxt" File.....	38
	Interpolation Table-Related Output: Section I.....	38
	The "MEANOUT.stxt" File	39
	Equilibrium Condition Summary: Section II.....	39
	The "OFFSETS.stxt" File.....	40
	Lateral Offset Restoring Characteristics: Section III.....	42
	Yaw Offset Restoring Characteristics; Section IV	42
	Oblique Axis Rotational Offset Characteristics; Section V.....	42
	Vertical Offset Restoring Characteristics; Section VI.....	43
	Oblique Rectilinear Offset Characteristics; Section VII.....	43
	Continuous Equilibrium Under Specified Forcing: Section VIII	43
	Continuous Equilibrium Under Specified Torquing; Section IX.....	43

Table of Contents

Appendix A	Glossary	44
Appendix B	Sample Problem	47
	Input Data.....	47
	Buoy Particulars:.....	47
	Catsim Screen Images of Imported CALMDAT File.....	48
Appendix C	File Management	51
	File Requirements	51
	Importance of Archiving CATIN.....	51
Appendix D	Auxiliary Data File Formats	52
Appendix Y	Buoy Alone Output.....	57
Appendix Z	Sample Problem Output.....	58

Chapter 1

Introduction

Background

Catsim is a member of the SeaSoft family of software packages for the offshore industry. These programs have been developed to provide easy to use, state of the art analytical tools for simulation of dynamic and static characteristics of a wide variety of offshore vessels and structures.

Objectives

Catsim has been developed to satisfy the need for a more comprehensive static catenary analysis product than the conventional "Hand of God" catenary mooring tools of which Statmoor is an example. Catsim and Statmoor are complementary in the sense that each has capabilities not found in the other, but there is considerable overlap as well. This will be explored further below.

Although Catsim was created to support other SeaSoft simulations, its power as a stand-alone utility should be self-evident. For better or worse, much engineering analysis done in the offshore industry remains limited to static and "quasi-static" studies, to which Catsim is directly applicable. And of course in the final analysis a *thorough* understanding of the mean forces and offsets relevant to an offshore system and environment is the essential bedrock upon which all dynamical understanding is built.

Catsim-Statmoor Differences

Capabilities of Catsim not available in Statmoor:

- The permitted mooring line complexity in Catsim is much greater. Each line can be composed of 16 sub-lines which can be of arbitrary composition; in particular, any element can represent a "buoy" in the sense that it can possess a negative "weight in water" value. Statmoor by contrast permits a maximum of 3 line elements plus one buoy and one clump weight at special locations along the mooring leg.
- The permitted types of "Hand of God" vessel offsets permitted by Catsim are much more complex and comprehensive than those in Statmoor. In particular, Catsim permits rectilinear offsets *in any direction*, including vertical and oblique offsets not lying in the waterplane, and rotational offsets *about any axis*, including non-vertical oblique axes. Statmoor, by contrast, permits only lateral vessel offsets confined to the "waterplane" and rotational (yaw) offsets about a vertical axis.
- In addition to the comprehensive "Hand of God" offsets permitted in Catsim, "instantaneous equilibrium" offsets are allowed in which the vessel responds to the development of mooring and hydrostatic forces and moments during the offset sequence in order to maintain at all

times a mathematically rigorous equilibrium. Such offsets will, in general, result in *simultaneous* translation *and* rotation of the vessel in any direction (including out of the waterplane) and about any axis (including non-vertical).

Capabilities of Statmoor not available in Catsim:

- Statmoor possesses comprehensive sloping bottom capabilities; Catsim accommodates individually specifiable anchor depths, but the sea bed between fairlead and anchor is treated as flat, not sloping.

Support of Related Simulations

Because of Catsim's primary role as a support utility for SeaSoft's comprehensive catenary mooring simulations (Moorsim, CALMsim, SPMsim, TLPsim), it is intimately related to all of these and designed to work seamlessly with them. It is expected that the primary application of Catsim will be to evaluate the static restoring characteristics of mooring systems and vessels already described within other simulation data files. The most common source of data for Catsim then will be existing CALMsim, SPMsim, etc. data files. These data files (CALMDAT, SPMDAT, etc.) can be copied directly into the Catsim working directory, renamed CATDAT, and loaded directly into Catsim for evaluation.

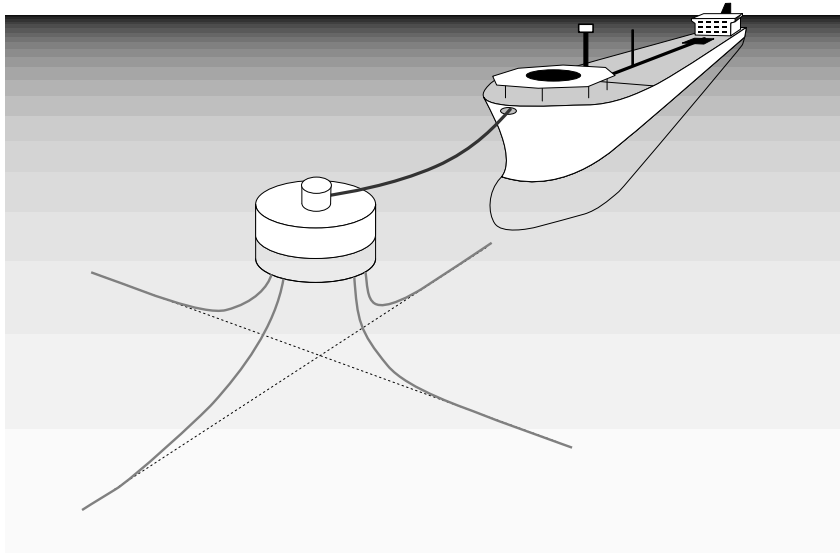

Two-Vessel Problems: CALMsim

CALMsim support is provided within Catsim by permitting analysis of buoy-hawser-tanker moorings. When CALMDAT files describing such systems are imported into Catsim, they are recognized automatically and some of the "exotic" analyses of Catsim are deactivated; the only analysis of these two-vessel system permitted are simple lateral offset sequences of both the "Hand of God" and "continuous equilibrium" types. The analysis will provide particulars of hawser load, individual buoy line loads and

vessel offsets as a function of buoy offset. In this analysis, the hawser is treated like any other mooring line, making available the full scope of Catsim's on-line support facilities.

Frequently Asked Questions (FAQ)

A database of "Frequently Asked Questions", or "FAQ", is maintained at the SeaSoft web site (<http://www.seasoftsys.com>) which contains a wealth of detailed real-life explanations and problem resolutions that supplements the User Manual, particularly for advanced users. In addition, the FAQ is updated more frequently than the user manuals and therefore may contain information pertinent to recent changes or additions that have not yet migrated into the manuals. The FAQ can be freely downloaded and searched by keyword(s); it is an invaluable resource for obtaining quick guidance on a wide range of issues from the mundane to the highly technical.

Chapter 2

Program Package Contents

The Catsim package comprises the user manual, the machine-executable program units, and support services provided by SeaSoft. The latter include bug reports, corrections and support of possible bug-related problems encountered during program execution.

Program Files

The disk files involved in a Catsim execution are of three generic types: binary program files, binary data files and formatted data files.

The sole executable binary program file is Catsim (the "Simulator"), which interacts dynamically (without user intervention) with a suite of binary overlay modules that are operating-system specific.

In addition to these executable modules, which are supplied with the package and which cannot be altered in any way by the user, a number of data files are created during the simulation process. These data files comprise two types, binary data files usable as input (CATDAT, CATBAK and LASTBAK) and formatted output data files (CATIN.stxt, CATOUT.stxt, MEANOUT.stxt, OFFSETS.stxt) containing input documentation and simulation output. Management and recommended archival procedures for these files are discussed in Appendix C.

The User Interface

The User Interface, an integral part of Catsim, is used to create and modify the input data file required for execution (called the "CATDAT" file). This input file contains physical information necessary for the simulation such as water depths, vessel physical characteristics, and so on. The file is the result of an interactive session between the user and Catsim (see Appendix B and Chapter 4 for a sample session). The Interface is also used to *modify* previously created data files when vessel characteristics, site or environmental conditions require changes. Note that the input file is in machine-readable format and cannot be viewed or modified without the Simulation.

User Manual Overview

The Catsim user manual constitutes the major tutorial tool provided with the program package. To derive maximum benefit, the manual should be thoroughly reviewed on two occasions: Upon initial package acquisition (before and during the first few simulation executions), and again after perhaps ten to twenty weeks of use. The second review, carried out after practical experience has been gained in the use of the program, is of inestimable value in sharpening the user's understanding of the program, its workings and its capabilities. The manual includes a reasonably extensive

glossary and an index, which, along with the table of contents and internal cross-references should permit quick location of specific topics.

Chapter 3 discusses the various classes of input data required and provides some details regarding special features and limitations of the simulation. It complements Chapter 4 by providing additional information on items of special importance and is therefore a valuable cross-reference point for the material in Chapter 4.

Chapter 4 gives a screen-by-screen description of input items required for Catsim and serves as a "super index" which can be used to answer most day-to-day operational questions that arise during Catsim execution. Cross-references to other portions of the user manual are given at appropriate points in Chapter 4.

Chapter 5 discusses in detail the Catsim output stream. It too is an important cross-reference point for Chapter 4, complementing the description of the output controls given there.

A collection of appendices provide a potpourri of miscellaneous useful information including file archive recommendations, a glossary and comprehensive sample problems (with input and output).

Automatic Backup of Input Files

When the Simulation is executed, it first inspects Catsim's local directory to see if any file with the name CATDAT is resident there. If so, a backup file named CATBAK is produced from the pre-existing CATDAT file while any pre-existing CATBAK file is copied to a file named LASTBAK. Any pre-existing LASTBAK file is lost. In this way, two generations of data files are maintained to protect against inadvertent data loss. This is discussed further under "file management" in Appendix C.

Chapter 3

Input Data Requirements

Catsim requirements for execution depend on the type of mooring analysis to be conducted. For example, a conventional lateral offset sequence, the "bread and butter" of mooring analysis for a hundred years, requires in addition to line characteristics only specification of the vertical height of each fairlead above its anchors to carry out the "Hand of God" offset analysis. If "Continuous Equilibrium" analysis is to be carried out, limited vessel hydrostatic information must also be supplied in order to compute the hydrostatic forces and moments associated with each offset position. Environmental data is not required since the possible analyses within Catsim are completely static in nature.

Data File Importation

As discussed in the Introduction, it is expected that the primary function of Catsim will be evaluation of mooring systems already described within other SeaSoft simulation data files. Only infrequently then will be a data file "Creation session for Catsim be required; rather most data will already be resident in existing Moorsim, CALMsim, SPMsim, etc. data files. These data files (MOORDAT, CALMDAT, SPMDAT, etc.) can be copied directly into the Catsim working directory, renamed CATDAT and "Modified in the usual way; all vessel and mooring system data contained in the imported file will thereby be automatically brought into Catsim leaving only output options to be set.

Notes:

- Care must be taken to *copy* rather than *move* the files as Catsim will modify them.
- Importation of vessels and mooring systems from *within* the Catsim Editor is also supported. See page 36 ff.

The Catsim user interface is identical in most respects to those of other comprehensive SeaSoft simulations with regard to definition of vessel and mooring system. Naturally, since static mooring analyses do not depend on environmental conditions, input relative to wind, waves or current is not relevant and any environmental data contained within an imported file will be invisible to the Catsim user *but is not lost*.

Importation of CALMsim Data Files

The input requirements for support of a CALM buoy-hawser-tanker system are only slightly more extensive than those for the CALM buoy alone. Normally the "storage vessel" in these analyses will be a tanker; we will usually refer to it as such.

Beyond the input requirements for a Catsim analysis of the moored buoy alone, hawser characteristics and hawser attachment points on buoy and tanker must be provided, along with tanker draft (for determining the absolute vertical location of the hawser fairlead at the tanker end). This supplemental information is included automatically in any imported CALMDAT file and will only need to be included manually if "C"reating a CALM-hawser-tanker system from scratch within Catsim.

Buoy-Along Analysis Considerations

When importing a CALMDAT file from CALMsim into Catsim, it is assumed that analysis of the entire buoy-hawser-tanker system is desired. When and if a stand-alone buoy analysis is desired, the hawser and tanker data must be "removed" from the data file. Files have been structured to make this process relatively painless (see page 35):

- Reduce the "Number of mooring legs" and the "Number of distinct mooring leg types" by one. This will "hide" the hawser data from Catsim, although the data remains in the file and *is not lost*. It may be recovered by reversing this procedure.
- Toggle the "Treat LAST line type/number as a hawser" flag to "No"
- Exchange the buoy and tanker draft and hydrostatic data by using the "Swap tanker, buoy data from CALMsim import file" facility on the second Catsim "Output Options" page (see page 35).

Data File Exportation

It is possible to *export* a Catsim data file back to its original application once imported into Catsim and modified. It should, however, be realized that Catsim alters data locations in the file that are unused in co-current versions of other SeaSoft simulations which *may* come into use in future versions; in that event unexpected and unanticipated conflicts may develop when updating old data files using the automatic data updating algorithms built into future SeaSoft simulations. To reduce exposure to these and other potential problems, you are advised to avoid exportation of Catsim data files back to the originating or to other SeaSoft simulations.

Mooring System Data

For purposes of quantifying its properties, the mooring line is logically decomposed into two levels of structure; individual "elements" or "sublines" of arbitrary size and mass properties, and "lines", which are by definition conglomerates of connected "elements" representing the fundamental mooring units.

Treatment of Submerged Buoys and Clumped Weights

Special line elements can be easily created which faithfully simulate the action of concentrated weights or of submerged or surface buoys. These special "sublines" should possess the net weight (or buoyancy) and the square-law drag properties of the simulated buoy or clump. The drag

coefficient times the net projected area (length times diameter) of the subline should match that of the modeled buoy or clump in order to properly mimic the important square-law drag forces. The net weight or buoyancy of the subline (length times submerged weight/unit length) should likewise match that of the buoy or clump. For this purpose, a negative submerged weight/unit length should be used for buoy simulations.

Risers and Other Mooring-Type Structures

Like buoys and clumped weights, production risers, SCRs (Steel Catenary Risers), etc., are all modeled as mooring elements, with exactly the same considerations as mooring lines. In particular, there is no capability to analyze or model bending stresses in these elements which, like mooring lines, are assumed to support only axial stresses.

Chapter 4

User Interface Description

This chapter is devoted to a description of the user interface to Catsim (the "Editor") which is employed for creation of new data files and editing of existing files.

The screen images presented here result from the importation of a CALMsim data file for static catenary analysis of (1) a buoy alone, without hawser or tanker and (2) a composite buoy-hawser-tanker system. Screen images relevant to the first case will be presented here and images relevant to the second case in Appendix B.

Since all options are represented by Editor selections, this chapter comprises an itemization of capabilities, input/output cross-reference and tutorial combined. All responses typed by the user at the console are in **bold** typeset, both on screen images and in the text of this chapter. User-typed carriage returns are indicated by `<c/r>`. Note that a carriage return (designated as "**Return**" on most keyboards but as "**Enter**" on some) is required as the last keystroke of *any* input to the console; thus, when we speak of "Entering the value 3", we in fact mean the keystroke combination "**3<c/r>**". (Quotation marks are included here and below *only* for readability; they are *never* to be used for data entry in the Editor.)

Screens are numbered sequentially according to the order of their appearance; unnumbered SubScreens that are subordinate to the main Screen but overlay it are designated by letter; SubScreen 3a would be the first SubScreen of Screen 3.

General Editing Information

The editing session is largely self-explanatory; the editing alternatives consist of several simple, fundamental types:

1. The "toggle": Many editing items are configured as toggles between two possible values; selection of these items will require no further data input from the user. For example, selection of "units of measure" on Screen 1 below will cause the selected units to toggle between "English" and "metric". All items displaying a value of "yes" or "no" are of the toggle type.

2. Single datum input: Most selections in the Editor require input or modification of a single item on a Screen. To change a particular item, input the item number followed by a carriage return (`<c/r>`) at the "Enter number of selection:" prompt, and an appropriate prompt line requesting the new input value will appear at the screen bottom. It is not necessary to input decimal points for floating point numbers with no fractional parts (i.e. 10.0 can be input as 10). When more than one input value is required

on an input line, the values should be separated by commas. A simple `<c/r>` in response to a request for data will leave the existing value of the data unchanged.

3. Expanded data input: For situations in which many numbers must be entered, or a choice more complicated than a simple datum input is involved, the Editor will produce a "SubScreen" subordinate to the active Screen to accomplish the input operation. For example, a SubScreen is used to permit semi-automatic input of the regular wave period array, the input of which one period at a time would be laborious.

4. Screen access "Help" menu: Entering "H" (*without* quotation marks) at any "Enter number of selection:" prompt will produce the page access Help menu displayed after console Screen 1 below. These paging options, which, like the "H" command, can be given at any "Enter number of selection:" prompt, are designed to permit ease of access to any Screen of the Editor from any other Screen. Both upper and lower case letters can be used.

The following mechanisms for paging through the Editor should be noted: To page forward to the next sequential Screen, press the carriage return at the "Enter selection number" prompt; to page *Backwards* to the previous Screen, enter "**B**<c/r>"; the *First* and *Last* input Screens can be accessed from any numbered Screen in the Editor by entering, respectively, "**F**<c/r>" or "**L**<c/r>"; one can *Skip* a Screen by entering "**S**<c/r>" or *Jump* to Screen "n" by entering "**Jn**<c/r>" (for example, **J5**<c/r> will produce a jump to Screen 5 from any numbered Screen in the Editor).

5. Help with specific items: Concise descriptions of many input items can be obtained on-line by entering "?n<c/r>" at any "Enter selection number" prompt; n is the item number of interest on the current Screen. Entering "?<c/r>" will cause all help text associated with the Screen presently in view to scroll by.

Editor Screen Images

The Screen images in this chapter correspond to the sample problem of Appendix B, to which reference should be made in order to fully appreciate the flow of logic and presentation of material in this chapter.

```

+-----+
|                                             |
|               **   Welcome to Catsim   **   |
|                                             |
|                Catsim   Version 5.05      |
|                                             |
|          Copyright (C) 2004 by SeaSoft Systems    |
|                                             |
+-----+
-----
(M) Modify existing data file, (C) Create a new file, (E) Execute simulation
Enter letter of selection: M<c/r>

```

Title page: This Screen presents options to Modify (**M**) an existing Data file, Create (**C**) a wholly new one or Execute (**E**) the Simulation using an existing Data file. No response but "**M**", "**m**", "**C**", "**c**", "**E**" or "**e**" will be accepted. If either (**M**) or (**C**) are entered, any first or second generation Data files in the current directory will be copied to backup files to avoid inadvertent loss of data. Thus, the two most recent generations of data files are automatically preserved. At the end of the Editor session, a Data file with the new or modified data will be created in the current directory in addition to the two generations of backup files. Appendix C discusses file management recommendations.

```

*****   Screen 1: Site conditions   *****

Two-line Identification for this simulation:

1) [Sample Problem: Catsim support of CALM installation      ]
2) [Buoy-alone configuration                                 ]

3) Units of measure: Metric

4) Site water depth:              35.00 meters
5) Water density:                 1025.18 kgw/cubic meter

Enter number of selection: H<c/r>

```

Screen 1: This Screen contains necessary site data and other miscellaneous information. The units of measure can be toggled between English and metric by selecting item 3. Input of new numerical data (e.g., item 4) or character string data (e.g., item 1) is accomplished by selecting the relevant numbered item and responding appropriately to the ensuing prompts.

```

(F) First page
(L) Last page
(S) Skip ahead a page
(E) Execute program
(B) Back a page
(Jn) Jump to page "n"
(?) Help summary for current page
(?n) Help on current page for selection "n"

```

Press <RETURN> to continue: <c/r>

Help Screen: This Screen contains instructions for access to various interface Screens and on-line help. The described actions are accomplished by entering the appropriate letter (uppercase or lowercase), followed by a carriage return, at an "Enter number of selection:" prompt on any page-numbered Screen.

```

**** Screen 2: General Mooring Information ****

```

```

1) Number of mooring legs (Max 49) ..... 6
2) Number of distinct mooring leg types (Max 49) ..... 1
3) Maximum interpolation table horizontal load ..... 750.00 metric tons
4) Smallest nonzero horizontal load ..... .10 metric tons
5) Number of points in interpolation table(s) ..... 30
6) Mean line profile determined by ..... line tension
7) Modify individual values of line tension

8) Default bottom friction coefficient ..... .00
9) Treat LAST line type/number as a hawser ..... No
10) Vessel draft ..... 3.50 meters
11) Vessel trim angle ..... .00 deg
12) Vessel heel angle ..... .00 deg

16) Reset default Anchor depth ..... 35.00 meters
17) Specify anchor depths individually ..... Yes
18) Default bottom boundary is "transparent" ..... No
19) First buoyant element stays at or below waterline: No

```

Screen 2: This screen contains miscellaneous data pertaining to the overall physical description of the mooring system.

Note: In the case of buoy-hawser-tanker systems, the hawser line is treated exactly like any other mooring line. In the present case, we would specify 7 lines and two line types, with the 7th line and the second line type being associated with the hawser. See page 49 ff for Screen images just after importation of the CALMDAT file. Item 9 is toggled to "Yes" to inform Catsim of the change from single-vessel to buoy-hawser-tanker configuration. The tanker draft and hawser attachment points will then be requested.

- Item 1: The total number of mooring legs; that is, the total number of fairlead points. A "mooring leg" comprises the entire mooring line from fairlead to anchor. This number should include all structures simulated as "mooring legs", including risers, etc.
- Item 2: Two mooring legs are indistinguishable only if their mooring elements (sublines, buoys, etc.) are identical *and* their anchor depths and fairlead heights are the same.
- Item 3: This specifies the largest horizontal load value used in the internally computed static load versus offset tables. Generally speaking it should be comparable to the breaking strength of the weakest subline in the system, although it can take any value. Selection of an excessively large value will result in unnecessarily inaccurate interpolated values. Selection of an excessively small value may result in the table bounds being exceeded during interpolation near large offset values.
- Item 4: This value specifies the first *nonzero* horizontal load in the internally computed load versus offset tables; it thus defines the *second* row in the tables since the first row corresponds to *zero* horizontal load. It should normally be *smaller* than any anticipated quasi-static line load; a typical range comprises 0.1% to 1% of the maximum horizontal load. If this value is set exactly to zero, the Simulation will choose a reasonable default value. When buoyant elements (represented by negative values of weight/unit length) are present, table rows associated with several of the smallest values of horizontal tension represented in the interpolation table may represent unphysical line configurations (see, for example, the discussion of Item 19).
- Item 5: The number of points in the interpolation table influences the computer time required for simulation and the volume of output in the interpolation table stream. Normally, this should be set to its maximum value (90).
- Item 6: The line profile associated with the null-environment "pretension" condition can be defined by specifying any of the following "pretension variables":

1. Vertical line departure angle at fairlead

The vertical line departure angle at fairlead is given in degrees from the horizontal; i.e., smaller angles correspond to higher pretensions.

2. Horizontal distance from fairlead to anchor

This refers to horizontal distance as seen in plan view. The facility for specifying horizontal distances from anchor to fairlead is useful for exploring the effect of changes in water depth as might occur, for example, due to the action of tides. One first executes at the nominal water depth with the desired line tension or declination angle at the fairlead. Anchor distances for this nominal condition are then used as data for a second run with the same line lengths but new anchor and water depths.

3. Total fairlead tension

4. Horizontal component of tension at fairlead.

- Item 7: Selection of this item produces a SubScreen to input the required numerical values of the chosen pretension variables.
- Item 8: The bottom friction coefficient affects tension estimates evaluated at the anchor by reducing all reported anchor loads by the weight of line lying on the bottom times the specified coefficient; it has no effect on fairlead load estimates.
- Item 9: In order to accommodate tanker-hawser-CALM buoy systems, thereby providing support for CALMsim in particular, the hawser, when present, is defined like any other mooring line but is handled differently by Catsim. Therefore, Catsim needs to know whether or not a hawser and second vessel are involved; this item provides that information. When this toggle is set to "yes", the last line number/type will be treated as a flexible hawser connecting a storage vessel to a conventionally moored CALM-type buoy. In this case, only line loads resulting from pure lateral offsets of the storage vessel can be evaluated. Appendix B and Appendix Z contain a demonstration of this capability.
- Item 10: Vessel draft comprises mean draft in the simulated condition. That is, if nonzero trim or heel are specified, the specified "mean" draft should correspond to the draft, at the same displacement, realized under conditions of zero trim and heel. Draft is required *only* to determine the vertical distances from anchor to fairlead (fairlead locations are given in vessel coordinates, relative to vessel keel). In the case of buoy-hawser-tanker systems, *both* vessel drafts will be requested.
- Items 11 & 12: Trim and heel angles can be specified in degrees with positive angles corresponding to "right-hand rule" positive rotations about the pitch (Vy) and roll (Vx) axes, respectively. The "zero-offset" plan-view vessel equilibrium point will reflect the influence of any vertical displacement of the fairleads resulting from initial trim/heel angular offsets.
- Item 16: Changes the default anchor depth for each mooring leg. When changed, the new default anchor depth will be applied to all mooring legs; anchor depths for each leg can be individually specified by setting the "Specify anchor depths individually" toggle to "Yes" and re-defining the desired anchor depths on the "Anchor" subline Screen for each mooring leg type.
- Item 17: When this toggle is set to "No", the indicated default anchor depth will be used for all anchor legs. To specify anchor depths individually, toggle this value to "Yes". Anchor depths are then set on the "Anchor" subline Screens for each line type.
- Item 18: When this toggle is set to "No", the normal solid-bottom condition applies; that is, in the absence of uplift at the anchor, there is line lying on the ocean bottom. When the toggle is set to "Yes", the bottom is "transparent"; that is, the line is allowed to hang from the anchor as if there were no bottom. This feature is normally used in conjunction

with individually set anchor depths for mooring to towers or docks where the bottom boundary is absent. The boundary condition for individual line types can be set on the "anchor" SubScreen.

- Item 19: When this toggle is "Yes", the *first* (if any) buoyant element in each line type (i.e., the closest to the fairlead) is restricted to lie at or beneath the water surface; this capability is provided to permit analysis of surface-resident "spring buoys" common in some offshore terminal applications. When this toggle is "No", the water surface is "invisible" to *all* buoyant line elements. This can, in some cases, result in a simulated buoyant element positioned *above* the waterline, a physically impossible condition which nonetheless may be useful in special situations.

```

**** Screen 3: More General Mooring Information ****

1) Number of mooring legs associated with each type --
   6 in Type A

2) Number of sublins associated with each type (max 10) --
   1 in Type A

3) Edit fairlead positions
4) Edit plan-view line departure angles

5) Edit mooring moment evaluation center

7) Vessel heading in quiescent conditions:      .00 Degrees

10) Number of excluded or broken lines:  0

```

Screen 3: This screen contains additional miscellaneous data pertaining to the overall physical description of the mooring system.

- Item 1: The number of mooring legs associated with each physically distinct line type must be given. These values must sum to the correct total number of lines or an error message will be displayed. Recall, two line types are distinct if the anchor depth, fairlead height or any subline differ.
- Item 2: The number of sublins associated with each distinct line type must be specified. The maximum value applies *not* to the total number of sublins but to the number of sublins in each line type. Buoys and clump weights should be counted as sublins; a single mooring leg broken in the middle by a spring buoy would therefore require a minimum of 3 sublins for proper specification.

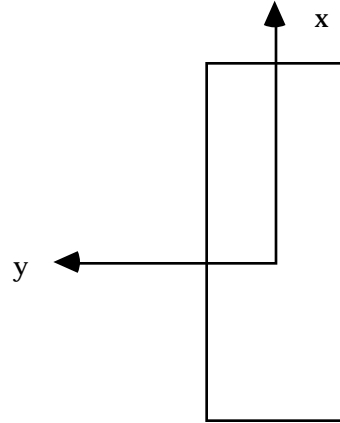

- Item 3: The vessel coordinate system, which is used to define fairlead locations in space, is a right-handed system with x pointing towards the bow and y to Port (left when facing forwards). z is positive upwards, measured from vessel keel. The *plan-view* origin of coordinates is at vessel cg.

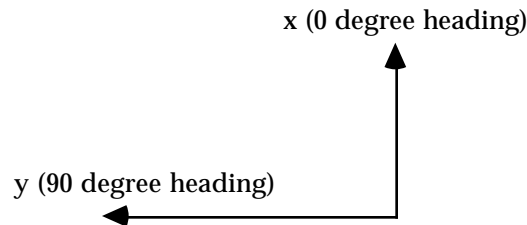

- Item 4: Plan-view line departure angles are defined in a "right-handed" earth-fixed ("Global") coordinate system with z positive upwards. The zero of angle is in the positive x direction; angles increase in a counter-clockwise direction. Thus, 90 degrees lies along the positive y axis. With a vessel heading of zero degrees, the global coordinate system coincides with the vessel coordinate system.
- Item 5: The point about which mooring moments are evaluated must be specified by the user. The point is given in the vessel coordinate system with (0,0,0) being at keel level (usually, directly underneath the vessel centroid).
- Item 7: The initial (zero environment) vessel heading relative to the "Global" zero of angle must be given. The Global x axis is often taken towards the North, but this is arbitrary; the Global zero angle can be chosen to lie along a particular mooring leg, for example.
- Item 10: To simulate line failures, any number of lines can be excluded during analysis. Note that this will affect the equilibrium-determination process and the resulting distribution of loads across the remaining uncompromised lines.

When the "excluded line" value is nonzero, the line numbers to be excluded must also be specified. In line-related tabular portions of the output stream, all loads and geometrical properties (angles, etc.) of these excluded lines will display as zero (0, 0.0, etc.) to permit identification of the excluded lines.

```

***** Screen 4A: Subline Specifics *****
("C", "D", "I", "X" to Copy, Delete, Insert, Exchange)

---> Subline attached to fairlead
---> Subline attached to anchor

1) Mooring leg type A (type 1 of 1)
2) Subline number: 1 of 1

3) Subline composition ..... Chain
4) Subline length ..... 457.00 meters
5) Subline outside diameter ..... 102.00 millimeters
6) Immersed weight/unit length ..... 208.83 kgw/meter
7) Dry weight/unit length ..... 240.33 kgw/meter
8) Breaking strength ..... 788.75 metric tons
9) Added mass coefficient ..... 1.00
10) Transverse drag coefficient ..... 2.50

11) Take elastic properties from an input file? .. No
12) Compliance coefficient #1 (alpha1) ..... 0.120E-04 (m.ton)**-1
13) Compliance coefficient #2 (alpha2) ..... 0.000E+00 (m.ton)**-2
14) Compliance coefficient #3 (alpha3) ..... 0.000E+00 (m.ton)**-3

16) Bottom is transparent to mooring line ..... No
17) Anchor depth for this leg type ..... 35.00 meters

20) Type A line numbers: 1, 2, 3, 4, 5, 6,

21) >> HELP << for subline physical property estimates

```

Screen type 4: The essential features of this Screen type are repeated a number of times equal to the sum of the number of sublimes over all line types as specified on Screen 2. Screen 5A, 5B, etc., refer to line types A and B (or, equivalently, 1 and 2), etc., and is repeated a number of times equal to the number of sublimes in each line type.

Note: When there are more than 26 line types (the 26th type being type "Z"), line identifiers in the editor and output stream track the ASCII character sequence; thus line 27, 28, 29, ..., 49 are line types "[", "/", "]", ..., "q". Thus, it is possible to have both a line type "A" and a line type "a" which are different. In that situation, when moving between line types using item "1" in the screen above, you will have to use the line *number* rather than its ASCII equivalent, because ASCII entry is case insensitive and will only accept values in the range [A-Z] or [a-z]. This circumstance is indicated in the response prompt to the item "1" selection and should therefore cause no confusion.

These Screens possess powerful "C"opy, "D"elete, "I"nsert and "X"change facilities to ease data manipulation of identical or similar line segments. Input of "C" (*without* quotation marks, as always) will produce prompts to accomplish an automated copy from a previously defined line type and subline number. Input of "D" will completely

delete the current subline; data for all larger subline numbers of the same line type thereby "collapse" by one subline number. In the above Screen, for example, the data for subline 2 of type A would "fall" into the current Screen and the subline 2 Screen would become void of data. Input of "I" pushes all subline data up by one number and clears all data from the current Screen. In order to simply clear the current Screen without effecting other subline data, input "D" followed immediately by "I". Input of "X" will cause a series of prompts to be issued to determine whether it is desired to "exchange" only the *displayed* subline or whether the *entire* line type, including sublines not visible on the immediate Screen, should also be exchanged, and with which line type/subline the exchange should be made.

- Item 1: This item, if selected, will permit "jumping" to the first subline of any other mooring leg type, or, if a value larger than the maximum value of leg types is input, to the first subline of the last leg. Access to individual mooring leg Screens is accomplished by this means or by advancing, one subline at a time, from the current location.
- Item 2: This item, if selected, will permit "jumping" to any other subline of the current leg type, or, if a value larger than the maximum value for the current leg is input, to the last subline. Access to individual sublines is accomplished by this means or by advancing, one subline at a time, from the current location.
- Item 3: Subline composition is for output documentation only. The maximum number of ASCII characters that will be saved and displayed is 8.
- Item 4: Self-explanatory.
- Item 5: The diameter required is the "nominal" diameter as used in standard line property tables. Thus, "3 inch chain" is fabricated out of 3 inch thick metal stock; the links themselves will be much larger in general. For standard cables of wire or synthetic material, the nominal diameter is the actual diameter of the cable. The diameter is used in hydrodynamic drag calculations and for the internal algorithms used to provide estimates of line weights, elastic properties and breaking strengths.
- Item 6: Self-explanatory. See page 20 for a special application of this item and page 7 for a discussion of buoy specification.
- Item 7: The dry weight/unit length (i.e., the line inertia) influences dynamical line load variations arising primarily from wave-frequency fairlead motions. A dry weight/unit length of zero or less will cause the simulation to produce an estimate equal to the immersed weight/unit length plus a displacement correction based on the subline diameter.
- Item 8: Breaking strength is used only in checking the load range to be covered by the force versus offset interpolation table produced internally for each line.
- Item 9: Unused by Catsim.
- Item 10: Unused by Catsim.

Item 11: When this toggle is set to "Yes", elastic properties for the active page's (type, subline) will be read from a user-supplied ASCII database file named "LINE_STRAIN_DB.txt". The file is comprised of a repeating block of ASCII data, one block for each (type, subline) page for which the toggle indicates "yes". See Appendix D for datafile description and example.

Items 12-14 The compliance coefficients (alpha1, alpha2, alpha3), abbreviated here ($\alpha_1, \alpha_2, \alpha_3$), are defined by a cubic tension-elongation characteristic:

$$e(t) = \alpha_1 t + \alpha_2 t^2 + \alpha_3 t^3$$

where "e" is strain (dimensionless) and "t" is tension (in kips or metric tons). Thus a strain of $e = 0.1$ means a stress-associated elongation of 10%. For materials possessing an approximately linear tension-elongation characteristic (e.g., wire rope and chain), $\alpha_2 = \alpha_3 = 0$ and

$$\alpha_1 = 1/(AE) = 1/[(\text{effective Area}) * (\text{Young's modulus})]$$

Note: Because of the use of "nominal diameter" in the definition of chain size, care must be taken when inferring the "effective" AE for chain from the AE of the stock material. In all cases, the first equation above defines unambiguously what is meant by the " α " coefficients. Checking user-supplied line properties with internal estimates will help to avoid errors.

Item 16: This item is displayed only for the "Anchor" subline and only if the "Specify anchor depths" toggle on Screen 2 is set to "yes", in which case anchor depths may be specified at different levels to simulate the effects of irregular bottom conditions or anchor placement on towers or docks. See the related comments on pp 12 ff. Note that this capability does *not* rigorously simulate a sloping bottom. Each anchor and its associated anchor leg are treated as if they lay on or above a level ocean bottom, whose depth can be made to vary from line to line by this mechanism.

Item 17: This item is displayed only for the "Anchor" subline and only if the "Specify anchor depths" toggle on Screen 2 is set to "yes".

Item 20: The line numbers associated with each line type must be specified; this item only appears on the "Fairlead" Subline page for each type.

Item 21: Selection of this item produces a Screen which will facilitate the estimation of weight/unit length, breaking strength and elastic coefficients for many mooring materials including IWRC wire rope, ORQ chain and a number of synthetics including nylon, Nystron, polypropylene and polyester. Selection of this Item calls up the following help Screen:

```

**** Simulation Help Facility ****

1) HELP with submerged weight per unit length...
2) HELP with breaking strength...
3) HELP with compliance coefficients...
4) HELP with dry weight per unit length...
5) Fairlead subline length for specified tautwire tension...

Enter number of selection ("H" for help):

```

SubScreen 4a: This is the Line Help Facility SubScreen. These calculations depend on the line diameter displayed on the Calling Screen from which Help was requested. Also, the line type (chain, wire, ...) required for specifying weight, strength, etc., is taken, not from the "subline composition" on Screen 4, but from a subsequent Screen display (see below).

- Item 1: Submerged weight per unit length in air, seawater or freshwater will be estimated for the specified line diameter and line type.
- Item 2: Breaking strength will be estimated for the specified line diameter and line type.
- Item 3: Compliance coefficients will be estimated for the specified line diameter and line type. Either the built-in compliance database or a user-input tension versus elongation curve can be used (see below). Compliance properties can, alternatively, be prepared and supplied via an external data file as described in the first "Screen 5" discussion block above.
- Item 4: Dry weight per unit length (i.e., the weight per unit length in air) will be estimated for the specified line diameter and line type.
- Item 5: This item is normally used for taut-wire or tension-leg calculations. Its selection results in the computation of the length of fairlead-attached subline required to produce the requested pretension for the associated Screen 4 line type. The line is assumed to be perfectly vertical for the calculation and to have a height-dependent local strain due to its self-weight. *All* weights and elastic coefficients for sublimes of the relevant line type must first be provided.

```

*** Help for line compliance coefficients ***

    >>> Chain Types <<<

1) Stud-link chain (generic O.R.Q.; 1975)
2) Stud-link chain (Ramnas O.R.Q.; 1994)
3) Studless Grade RQ4 Chain
4) Inextensible stud-link chain

    >>> Wire Rope Types <<<

6) I.W.R.C. wire rope (O.R.Q.)
7) Brydon spiral strand wire rope (unsheathed)
8) Brydon spiral strand wire rope (unsheathed; remodeled 1995)

    >>> Synthetic Rope Types <<<

11) Kevlar stranded rope (Samson)
12) Braided nylon rope (Samson "two-in-one")
13) Samson Nystron rope
14) Vermeire 100% polyester braided rope
15) Vermeire "Monogrip" 100% polypropylene rope
16) Vermeire manilla rope

Enter number of selection ("H" for help):

```

A window similar to the one above is displayed for most help items 1-4 in order to specify the line material to be used in the estimate.

```

*** Help for line compliance coefficients ***

1) User-specified stress/strain curve
2) Built-in compliance coefficients

Enter number of selection ("H" for help):

```

The Compliance Coefficient Sub-SubScreen.

Item 1: A user-supplied array of (tension, elongation) data points will be used to estimate the three required compliance coefficients. (See input Screens associated with this item below.)

Note: The built-in curve-fitting routine associated with Item 1 produces a cubic stress-strain polynomial. This can at times can be problematic because of the vagaries of cubic polynomials. For more complex stress-strain curve shapes, the "LINE_STRAIN_DB.txt" mechanism, discussed further above and in Appendix D, should be used instead.

Item 2: A built-in database covering a number of important line types will be used to estimate compliance coefficients. In this database, chain, wire

rope and Kevlar exhibit Hooke's law behavior (linear stress-strain characteristic) using a *single* nonzero compliance coefficient; other synthetics will display three distinct coefficients.

```

Enter number of data points (max 20, min 4): 6

-->> Array input for NONZERO Tension values (a point at [0,0] is ASSUMED)

1)      10.00
2)      20.00
3)      40.00
4)      80.00
5)     160.00
6)     320.00

Enter number of selection ("H" for help):

```

In order to compute compliance coefficients from a tension-elongation curve, the number of data points to be used must first be specified (from 4 to 20), then the values themselves must be provided. This window illustrates a sample tension input array. Tension values must be given in simulation-consistent units (kips or metric tons). The data point (0,0) is automatically included; no zero values of tension or elongation will be accepted. The maximum input tension value should be 1.25 to 1.5 times the material breaking strength for best curve fitting results. Since manufacturers data obviously cannot go beyond the breaking strength, the data should be extrapolated in a reasonable way to the necessary unphysically large tension values. A linear extrapolation of the supplied curve will usually suffice.

```

-->> Array input for NONZERO Elongation values (a point at [0,0] is ASSUMED)

1)      .01
2)      .02
3)      .05
4)      .12
5)      .26
6)      .60

Enter number of selection ("H" for help):

```

This window illustrates a sample input of the elongation array associated with the tension array in the previous window. Elongation values are input as a decimal fraction (i.e., an elongation of 10% is entered as 0.1). The data point (0,0) is automatically included; no zero values of tension or elongation will be accepted. The built-in routine produces a simple cubic fit to the supplied data which will be either *unweighted* or weighted by [1/elongation]; a prompt will be given just before execution of the curve fit to implement this final choice. Weighting the fit with 1/elongation will usually produce a better fit to the data at lower tension values. It is instructive at least once to execute a fit both ways and

visually compare the resulting cubics (using a spreadsheet program, for example) against the data using the stress-strain relation given above with the output values of $(\alpha_1, \alpha_2, \alpha_3)$.

Tip: To achieve the most satisfactory cubic fit using this mechanism, the *density* of supplied points should be greatest in the tension region of most importance to the simulation (typically, near the upper end of the tension range).

```

**** Screen 5: "Hand of God" Offset Specifications ****

1) Number of <<lateral>> offset directions (Max 10) ..... 1
2) Number of lateral offsets per direction (Max 50) ..... 15
3) Specify lateral offset directions
4) Specify lateral offset values

5) Number of <<yaw>> offset directions (Max 2) ..... 1
6) Number of yaw offsets per direction (Max 50) ..... 15
7) Specify yaw offset sense
8) Specify yaw offset values

9) Number of <<vertical>> offsets (Max 50) ..... 15
10) Specify vertical offset values

```

Screen 5: The conventional "Hand of God" offset specification screen. Offsets in Catsim are of several types. The simplest types, with a long history of use in the offshore industry, we have called "Hand of God" offsets because the target vessel is assumed to move as a rigid body according to the prescribed offset sequence (rotation about an axis or rectilinear translation). During these offset sequences, the "Hand of God" prevents response of the vessel in any degree of freedom to mooring forces developed by the offset. The "Hand of God" offsets are further subdivided for convenience into "oblique" and "conventional" (or "non-oblique"). The latter include simple rectilinear lateral offsets *in the waterplane* which have been used for years in evaluation of force-versus-offset curves for mooring applications. In our classification, these lateral waterplane-restricted offsets are joined by simple yaw offsets (rotations about a vertical axis through the vessel cg) and purely *vertical* translations. Thus the "conventional" or "non-oblique" Hand of God offsets comprise any vessel offset sequence in which the motion of the fairleads is *parallel* or *perpendicular* to the waterplane. Oblique offsets, by contrast, form a more general set permitting rectilinear offsets in *any* direction and rotations about *any* axis. Obviously, the "conventional" offset family is a subset of the more general "oblique" offsets. The conventional offsets are given separate treatment on their own Screen because of their historical importance.

Item 1: Use this item to specify the total number of desired lateral offset sequences. Each "lateral" sequence comprises a collection of "Hand of God" offsets in a particular direction in the waterplane. That is, the vessel may not respond in any way to forces or moments developed by the mooring system during a specified offset sequence.

- Item 2: All lateral offset sequences share a common array of offset values. This option establishes the number of values in the array.
- Item 3: Use this item to define plan-view lateral offset directions in an earth-fixed "right-handed" coordinate system (the "Global" system) with z positive upwards. The zero of angle is in the positive x direction; angles increase in a counter-clockwise direction. Thus, 90 degrees lies along the positive y axis. With a vessel heading of zero degrees, this global coordinate system coincides with the vessel coordinate system.
- Item 4: This option establishes the array of lateral offset values common to all lateral offset sequences.
- Item 5: Use this item to specify the total number of desired yaw offset sequences. Each sequence comprises a collection of "Hand of God" offsets. That is, the vessel may not respond in any way to forces or moments developed by the mooring system during a specified offset sequence.
- Item 6: All yaw offset sequences share a common array of offset values. This option establishes the number of values in the array.
- Item 7: Only two possible yaw offset sequences exist; clockwise or counter-clockwise when viewed from above.
- Item 8: This option establishes the array of yaw offset values common to all yaw offset sequences.
- Item 9: A vertical offset sequence comprises a simple vertical (positive or negative) translation of all fairleads; useful, for example, to accommodate tidal variations in mooring loads. Use this option to specify the number of desired vertical offset points in the sequence.
- Item 10: This option establishes the required array of vertical offset values.

```

**** Screen 6: "Hand of God" Oblique Offset Specifications ****
1) Number of oblique directions for <<rectilinear>> offsets (Max 10) 1
2) Number of linear offset points per direction (Max 50) ..... 15
3) Specify rectilinear offset directions
4) Specify rectilinear offset values

5) Number of oblique axes for <<rotational>> offsets (Max 10) ..... 1
6) Number of rotational offsets per oblique axis (Max 50) ..... 15
7) Specify oblique axis directions
8) Specify oblique axis coordinate origin
9) Specify oblique axis rotational sense
10) Specify oblique axis rotational offset values

15) Take offset data from INPUTOFF.txt text file ..... No

```

Screen 6: The generalized "Hand of God" offset page comprising "oblique" rectilinear offsets in any direction (including offsets at an angle to the waterplane) and rotations about any axis (including axes

oblique with respect to the waterplane and to the vertical).

Item 1: Use this item to simulate "Hand of God" oblique rectilinear offsets; this means the vessel cannot respond in any way to mooring system forces or moments developed during the offset sequence. There are *no* restrictions on specified offset directions.

Note: Choose offset directions in the waterplane (G_x, G_y) or along a Global principal axis direction (G_x, G_y, G_z) to duplicate conventional "lateral" and "vertical" offset capabilities.

Item 2: Use this option to establish the number of values in the rectilinear offset array.

Note: All offsets of a particular type (i.e., rectilinear or rotational) share a common array of offset distance values.

Item 3: Specify each offset direction by a global vector (G_x, G_y, G_z) pointing in the required direction. Thus, specify offsets along the G_x axis by the vector (1,0,0) and offsets along the G_x - G_y diagonal by (1,1,0).

Note: Vector *magnitude* is unimportant; (1,0,1) is the same direction as (2,0,2), etc.

Item 4: This option establishes the array of offset values common to *all* oblique rectilinear offset sequences.

Item 5: Any (possibly oblique) line passing through the waterplane centroid can serve as rotation axis for "Hand of God" rigid-body rotations. In these "oblique" rotational offsets, the vessel cannot respond in any way to mooring system forces or moments developed during offset.

Note: Choose rotations about a vertical axis to duplicate the conventional "yaw" offset capability.

Item 6: Use this option to establish the number of values in the rotational offset array.

Item 7: Specify the desired rotation axis by any global vector (G_x, G_y, G_z) pointing along the desired axis. For example, roll simulation requires rotation about the vessel x-axis; an appropriate vector is thus (1,0,0) provided the global and vessel coordinate systems initially coincide. Similarly, a suitable vector for pitch simulation (rotation about the vessel y-axis) is (0,1,0). Specify a rotation about a horizontal axis lying at 45 degrees to the x- and y-axes with the vector (1,1,0).

Note: Vector *magnitude* is unimportant; (1,0,1) is the same direction as (2,0,2), etc.

Item 8: The (V_x, V_y, V_z) location on the vessel serving as the origin of coordinates for the oblique rotational sequence can be specified. The customary selection is the waterplane centroid (V_x, V_y, V_z) = (0,0,draft) since this is the point about which static rotations naturally occur. However, any

point whatever can serve as coordinate origin for "Hand of God" rigid-body rotations.

- Item 9: Specify the "sense" of each desired rotation. There are two possibilities: twist directions associated with advance (sense = +1) or retraction (sense = -1) of a screw with standard right-handed thread. (Such a screw advances according to the engineering "right-hand rule".)
- Item 10: This option establishes the array of offset values common to *all* oblique rotational offset sequences.
- Item 15: You may specify an arbitrary and completely generalized array of c.g. offsets and orientations (or, "offset 6-vectors") by preparing a text file named "INPUTOFF.txt". The structure of this file is described in Appendix D.

```

**** Screen 7: "Continuous Equilibrium" Static Offset Specifications ****

1) Number of directions for FORCE application (Max 10) ..... 1
2) Number of specified forces per direction (Max 50) ..... 15
3) Specify force directions
4) Specify force values
5) Specify point of force application on vessel
6) Force direction specified relative to GLOBAL coordinate system

7) Number of axes for force couple application (Max 10) ..... 1
8) Number of specified force couples per direction (Max 50) .. 15
9) Specify force couple axis directions
10) Specify force couple values
11) Force couple axis specified relative to GLOBAL coordinate system

12) Apply forces & force couples <<separately>>

14) Override default selection of vertical interpolation grid   Yes
15) Number of vertical interpolation layers (Max 29, Min 3) ... 7
16) Total span of vertical interpolation region ..... 28.00 meters

```

Screen 7: The generalized "Continuous Equilibrium" offset page. On this page, rather than specifying "Hand of God" offset *directions* and *distances*, one specifies *force and/or moment directions and magnitudes acting on the vessel*. The vessel offsets produced differ from "Hand of God" offsets in that the vessel responds and the mooring system adjusts at each specified force and/or moment value to create an equilibrium condition under the combined action of hydrostatics, mooring system, and specified forces. Forces may be applied in any direction and moments may be applied about any axis (including axes oblique with respect to the waterplane and to the vertical). These capabilities are useful, among other things, in damage stability analyses for moored vessels.

- Item 1: Use this item to choose the number of force application sequences.

Note: You may *simultaneously* simulate an applied force and moment sequence.

- Item 2: Use this option to establish the number of values in the force sequence.
- Item 3: Specify each force direction by a vector (x,y,z) passing through the specified point of application (see below) and pointing in the desired direction. Thus, specify forces along the x axis by the vector (1,0,0) and forces along the x-y diagonal by (1,1,0).
- Notes:**
- Vector *magnitude* is unimportant; (1,0,1) is the same direction as (2,0,2), etc. Also, *all* applied forces in a sequence have the *same* direction.
 - In the case of a CALM-hawser type system, only the first two (x,y) components of the vectorial direction will be used; the third component is determined internally from hawser endpoint fairlead locations and instantaneous CALM position and orientation and will override any value provided here. Also, for CALM-hawser systems, the direction must be specified using the *Global* (Gx,Gy) coordinate system. This treatment thus simulates a *horizontal* force, applied at the tanker end of the hawser, assuming no hydrostatic adjustment of tanker-end hawser attachment height but full hydrostatic adjustment of buoy pitch, roll and submergence (i.e., assuming the tanker to be infinitely large relative to the buoy).
- Item 4: This option establishes the array of force values common to *all* requested sequences.
- Item 5: The point of force application must be specified (in the vessel coordinate system) so that moments arising from the force can be computed.
- Item 6: The applied force direction can be specified in either the vessel or global coordinate system. For example, the action of vessel-fixed thrusters should utilize the vessel-fixed system, while a tugboat pulling in a constant earth-fixed direction should utilize the global system.
- Item 7: Use this item to simulate a specified sequence of "Continuous Equilibrium" *moments* acting about a specified axis. As for the analogous forced offsets, these differ from the "Hand of God" condition in that the vessel responds and the mooring system adjusts at each specified moment value to create an equilibrium condition under the combined action of hydrostatics, mooring system, and specified moment.
- Note:** You may *simultaneously* simulate an applied force and moment sequence.
- Item 8: Use this option to establish the number of values in the moment sequence.
- Item 9: Specify each moment axis by a vector (x,y,z), defined in either a global or vessel-fixed coordinate system and pointing in the desired direction. For example, a pure vessel rolling moment is associated with the x-axis; an appropriate vector is thus (1,0,0), defined in the vessel

coordinate system. Similarly, a suitable vector for pitch moments (applied about the vessel y-axis) is (0,1,0). Specify an oblique moment about a horizontal axis lying at 45 degrees to the x- and y-axes with the vector (1,1,0). Note that the right-hand rule and the direction of this vector establish the directional sense of the moment.

Note: Vector *magnitude* is unimportant; (1,0,1) is the same direction as (2,0,2), etc.

Item 10: This option establishes the array of moment values common to *all* moment sequences.

Note: All applied moments in a sequence share the *same* moment axis.

Item 11: The moment axis vector can be specified in either global or vessel coordinate system.

Item 12: Use this option to apply simultaneously the specified force and moment values; the alternative is to apply them independently. To simultaneously apply force and moment values, the *number* of force and moment sequences and the number of *values* in each sequence must be the same.

Item 14: When this item is visible, some of the requested offset types require vertical fairlead motions, which motions necessitate additional interpolation tables applying to vertical levels above and below the initial (zero-offset) fairlead locations. Use this toggle to specify the number and disposition of these levels or, alternatively, to request that they be set automatically by the program.

Item 15: Use this option to set the number of vertical interpolation levels, which must be an odd number greater than or equal to 3.

Item 16: Use this option to specify the vertical span necessary to contain the vertical fairlead motions. The value should be large enough that all fairleads remain confined vertically within the selected span as they move according to the requested offset sequence(s), but not so large as to greatly "overshoot" the vertical region of interest.

Notes:

- A reasonable limit on this span for rotations is twice the distance from the waterplane centroid to the most distant fairlead.
- During "Continuous Equilibrium" offset sequences, it is not possible in general to know ahead of time how far a vessel will move in response to the specified force sequence. If the vessel moves outside the permissible vertical bounds, a warning will be issued and the simulation can be rerun using larger vertical or lateral bound.

```

***** Screen 8: Vessel Hydrostatic Characteristics *****
1) Vessel displacement ..... 412.00 m.ton
2) Transverse metacentric height (KMT) ..... 4.30 m
3) Longitudinal metacentric height (KML) ..... 4.30 m
4) Vertical center of buoyancy (VKB) ..... 1.80 m
5) Vertical center of gravity (VKG) ..... 2.50 m
6) Vessel water plane area ..... 113.10 m^2
7) Length of vessel at waterline ..... 12.00 m
8) Beam of vessel at waterline ..... 12.00 m
9) Mean vessel draft ..... 3.50 m

```

Screen 8: The vessel definition screen is visible *only* if "Continuous Equilibrium" offsets have been requested. This is because during "Hand of God" offsets, hydrostatic forces acting on the vessel are ignored and there is no need for hydrostatic characteristics to be defined. For Continuous Equilibrium, the hydrostatic force *changes* are taken into account by including hydrostatic force and moment contributions to the force/moment balance according to the following rules:

$$\begin{aligned}
 d(\text{Heave Force}) &= D_w * AWP * dZ \\
 d(\text{Pitch Moment}) &= D_w * \Delta * GML * dP \\
 d(\text{Roll Moment}) &= D_w * \Delta * GMT * dR.
 \end{aligned}$$

Here D_w is water weight density, AWP is waterplane area, Δ is vessel volume displacement, GML , GMT the longitudinal and transverse metacentric heights above cg , (dZ , dP , dR) are respectively the differential vertical, pitch and roll motions. From the form of these relationships, it should be evident that the inclusion of hydrostatic effects is an approximate one, since no allowance is made for the *changes* in AWP , Δ , GML or GMT with changes in vessel position as it responds to the force/moment sequence. The procedure therefore is limited to force/moment sequences which produce negligible changes in these basic hydrostatic quantities. Normally, this will be an excellent approximation for pitch/roll angles up to about 10 degrees and draft changes up to about 20 percent. A more careful treatment would require the integration of a complete vessel hydrostatics package into Catsim and a comprehensive specification of vessel lines to support such an expanded hydrostatic evaluation.

Items 1-9: This screen is fundamental to all SeaSoft simulations; its description will not be reviewed further here. Refer to the on-line help accessible at this screen or the Shipsim or Moorsim manuals for further information, if necessary.

```

**** Screen 9: Pre-Offset Conditions ****

1) Compute initial offset from a prescribed force/moment:   Yes

2) X force component ..... .00 metric tons
3) Y force component ..... .00 metric tons
4) Applied moment (force couple) value ..... 0.000E+00 ton-meters

5) Auxiliary force components defined in <<global>> coordinate system

  ++> Coordinates of Applied Force are in <<vessel>> system

6) Applied force X-coordinate (from c.g.) ... .00 meters
7) Applied force Y-coordinate (from c.g.) ... .00 meters

10) Apply initial (non-equilibrium) vessel offset:   Yes

  ++> Initial offset values are relative to the <<global>> system

11) Initial X offset ..... .00 meters
12) Initial Y offset ..... .00 meters
13) Initial Z offset ..... .00 meters
14) Initial yaw offset ..... .00 degrees

```

Screen 9: This Screen permits a wide variety of *initial* (i.e., "pre-offset") configurations to be accommodated.

Thus, for example, any "Hand of God" offset sequence can begin from a user-specified non-equilibrium *location* or with the vessel positioned according to a user-specified non-equilibrium force or moment combination. Initial forces must be in the waterplane; initial moments must be about the vertical (z) axis.

Note: Specification of initial forces or offsets are inconsistent with "continuous equilibrium-type offsets; this screen is therefore suppressed if any Screen 8 "continuous equilibrium offsets have been requested.

Item 1: Use this item to simulate a constant force and/or moment acting in either the vessel or global coordinate system; this will produce a new equilibrium point displaced from the original unforced equilibrium point. All requested offset sequences will then take place about this displaced equilibrium point.

Items 2-4: Use these options to specify the magnitude of the indicated force or moment. Note that the moment specified in item 4 should be a pure *couple* about the specified force application point.

Item 5: Use this toggle to specify whether the applied force remains constant in the "vessel" or "global" coordinate system. For example, the action of a vessel-fixed thruster is constant in the vessel-fixed system, while a tugboat pulling in a constant earth-fixed direction is constant in the global system.

Items 6-7: Use these options to specify the plan-view point of application of the prescribed force. The (Vx,Vy) coordinates of this point are *always* given in the vessel coordinate system, a right-handed system with Vx pointing towards the bow and Vy to Port (left when facing the bow). Vz is positive upwards. The plan-view origin of coordinates is the vessel center of gravity.

Note: Any force not acting through the vessel cg will automatically produce a moment about the cg. The force couple specified here is *in addition to* and independent of any moment resulting from the action of the specified force.

Item 10: Use this toggle to specify a starting (non-equilibrium) global offset point and orientation directly, without specification of a force and/or moment. (The output stream will document the force and moment required to *produce* the requested offset.) All specified offset sequences will then use this point and/or yaw orientation as the starting condition for requested offset sequences.

Items 11-14: Specify the requested initial position by a global offset (Gx,Gy,Gz and yaw) from the equilibrium point and orientation associated with the unforced system equilibrium condition.

Note: The initial force and offset specified here are treated differently in one minor respect. In Output Section II (see Chapter 5) the initial *offset* is ignored in producing the MEANOUT file, while the initial *force* is not but is rather treated like a steady environmental offsetting force. However in the *remainder* of the Catsim output stream (comprising principally the OFFSETS file) the initial conditions specified on this page are *additive* in the sense that the initial offset is as specified and the initial *force* is carried through in all force calculations and force balances. This asymmetry of treatment is related to the role of MEANOUT in reporting, when necessary, failures of the user-supplied pretensions to produce a true equilibrium.

```

**** Screen 14: Output options 1 ****
1) Output static offset data ..... Yes
2) Output element endpoint & angle interpolation tables ..... No
3) Compute quiescent equilibrium ..... Yes
4) Output mean orientation & line loads data ..... Yes
    
```

Screen 14: Options to reduce/expand the volume of the output stream.

Item 1: Causes the interpolation table data and other static mooring information to be output.

Item 2: "Element endpoint & angle interpolation tables" are somewhat

voluminous and infrequently needed. They can be eliminated from the output stream using this option.

- Item 3: If the supplied line pretension conditions and line layout do *not* result in an equilibrium condition (that is, the sum of all mooring forces and moments acting on the vessel do not vanish), new pretensions close to the originals will be determined which *do* produce equilibrium. The simulation can, however, be forced to use the original specified (non-equilibrium) configuration by setting this toggle to "No".
- Item 4: Selects for output, at the computed (or user-specified) produced mean offset positions, a line tension and departure angle summary.

```

**** Screen 15: Line-Specific Options ****

>>> Line Tension Data (global, waterplane-relative) <<<

1) Total line tension at fairlead ..... Yes
2) Net Horizontal tension at fairlead (Gh = Gxy) ..... No
3) Vertical tension component (Gz) at fairlead ..... No
4) Net Horizontal tension component at anchor (Gh = Gxy) ..... No
5) Vertical tension component (Gz) at anchor ..... No

>>> Length & Distance Data <<<

6) Total suspended line length ..... No
7) Line lying on bottom ..... No
8) Fairlead-Anchor distances ..... No

>>> Angle Data (global, waterplane-relative) <<<

9) Declination angles at fairlead (from horizontal) ..... No
10) Line uplift angle at anchor (from horizontal)..... No
11) Plan-view line departure angles (global-zero relative) .... No

```

Screen 15: Individual line output options for line-specific variables.

- Items 1-5: Select various components of line tension to be output for each offset sequence point.
- Item 6: Line lengths are reported as "unstretched" lengths; that is, line length after elimination of all internal stresses. This length is always somewhat less than the length of the same amount of line under load.
- Item 7: Total length of line from touchdown point to anchor.
- Item 8: Total plan-view distance from fairlead to anchor.
- Item 9: Line departure angle from the fairlead is measured from the horizontal, positive downwards.
- Item 10: Line departure angle from the anchor is measured from the horizontal, positive upwards.

Item 11: Use this item to generate plan-view line departure angles at the fairlead for each offset point.

```

**** Screen 16: Net Vessel Loads & Miscellaneous Options ****

      >>> Net Mooring Loads <<<

1) Net loads/moments (vessel-bound, deck-relative) ..... Yes
2) Net loads/moments (global, waterplane-relative) ..... No

      >>> Stiffness Variables <<<

3) 6x6 Stiffness matrix (vessel-bound, deck-relative) ..... Yes
4) Prepare standard mooring stiffness matrix

5) 6x6 Stiffness matrix (global, waterplane-relative) ..... No

7) Differential increment for *Cartesian* degrees of freedom .100 meters
8) Differential increment for *angular* degrees of freedom .100 deg.

      >>> Energy & Cross-Coupling Data <<<

10) Line & system potential energy analysis ..... No
11) Cross-coupling summary ..... Yes

      >>> Miscellaneous Options <<<

21) Permit offsets beyond interpolation table ..... Yes
22) Output page of oblique offset definitions ..... No
23) Adjust NET mooring loads at initial offset to zero ..... No
24) Fairleads attached to rotating turret? ..... No
25) Use double precision for stiffness matrices? ..... No
26) Prepare TLP-style interpolation tables? ..... No

31) Swap tanker, buoy data from CALMsim import file

32) Debug option is on ..... No
    
```

Screen 16: System-wide net load options, etc.

Items 1 & 2: Net mooring forces and moments can be computed in either a vessel-bound, deck-vertical system or an earth-fixed, waterplane-relative system or both.

Items 3 & 5 The mooring stiffness comprises, at each requested offset point, a 6x6 matrix containing all 36 components of the mooring line force/moment versus coordinate/angle cross derivatives. Its form is:

dF_x/dx	dF_y/dx	dF_z/dx	dM_x/dx	dM_y/dx	dM_z/dx
dF_x/dy	dF_y/dy	dF_z/dy	dM_x/dy	dM_y/dy	dM_z/dy
dF_x/dz	dF_y/dz	dF_z/dz	dM_x/dz	dM_y/dz	dM_z/dz
dF_x/dP_x	dF_y/dP_x	dF_z/dP_x	dM_x/dP_x	dM_y/dP_x	dM_z/dP_x
dF_x/dP_y	dF_y/dP_y	dF_z/dP_y	dM_x/dP_y	dM_y/dP_y	dM_z/dP_y
dF_x/dP_z	dF_y/dP_z	dF_z/dP_z	dM_x/dP_z	dM_y/dP_z	dM_z/dP_z

Here the F's are mooring force components, M's are moment components, (dx,dy,dz) is the coordinate differential and (dPx,dPy,dPz) are differential angles about the indicated axes. The matrix can be evaluated in either a vessel-bound, deck-vertical system or an earth-fixed, waterplane-relative system or both. Moments are computed about the user-specified moment origin (as opposed to the waterline, center of gravity or mooring centroid). The units of the matrix elements are in the units of the simulation, for example, kips/ft, kips/radian, kip-ft/ft or kip-ft/radian.

Items 4 & 6: If the 6x6 mooring stiffness matrix is evaluated for an equilibrium mooring configuration, it can be formally shown to be fully symmetric across its diagonal because gravitational forces can be derived from a scalar potential function. However, for Catsim's offset sequences, the "Hand of God" (or any other applied force and/or moment required to achieve the offset) breaks this symmetry and the mooring stiffness matrix becomes assymmetric.

Because the combination of mooring line forces *plus* the applied force are always in equilibrium, regardless of the type of offset, a fully symmetric stiffness matrix can be obtained by including the (constant) applied offsetting force and moment with the mooring forces in the calculation. This option permits evaluation of this *symmetric* matrix which adds the applied force and moment contribution to the purely mooring-line related forces.

Items 7 & 8: These options permit user adjustment of the default values for lateral and angular differentials needed for finite-difference stiffness matrix evaluation. They must be nonzero or the simulation will crash.

Note: When requested, stiffness matrices are produced for every offset of every requested sequence; this can introduce a large amount of data into the output stream.

Item 10: Line and system potential energy as a function of offset. The zero of energy for each line type is referred to the fairlead position associated with zero horizontal force (i.e., the first row of the interpolation table) and, in the event vertical offsets are required, the lowest fairlead position in the resulting vertical interpolation grid.

Item 11: The cross-coupling summary provides an analysis of forces and moments produced by the specified offset sequence(s). This includes, for example, net mooring load orthogonal to the offset direction and net pitch, roll and yaw moments generated by the offset(s).

Item 21: Use this toggle to suppress or include output for offset values exceeding interpolation table limits when the requested offset sequence exceeds the interpolation table bounds. When set to "Yes", the offset value which first exceeds the interpolation table bounds is noted on all output pages both graphically (with a right arrow symbol ">") and descriptively at the bottom of each affected output page.

Item 22: Use this toggle to suppress or include an output page defining various output items relating to the "oblique offset" options.

- Item 23: Use this toggle to adjust all *net* moments and loads to vanish at the initial offset point by subtracting the initial (zero-offset) net moment and load from the entire offset sequence. Alternatively, the actual (unadjusted) net moment and load values will be reported at every offset point. For example, the initial net vertical mooring load will seldom vanish, but can be set to zero by subtracting the non-zero initial value from every vertical mooring load in the sequence.
- Item 24: Fairleads can be fixed relative to the vessel (the usual spread-moor condition) or can be free to rotate about their plan-view centroid to simulate the action of a freely rotating fairlead support turret.
- Item 25: When toggled to "yes" this item will cause a subset of the stiffness matrix calculations to be carried out in double precision. This will generally improve the precision of the matrix elements, although because most calculations are still carried in single precision, the use of this option is currently of limited utility and is primarily included as a debugging tool to assist SeaSoft. It should be considered an unsupported feature until further notice.
- Item 26: When set to "yes", this toggle causes TLP-style interpolation table layers to be produced, thereby facilitating the study of tendon-type structures. Because these structures are extremely stiff, they permit substantial fairlead excursions only in the *downwards* direction. Therefore, interpolation layers need not be approximately symmetric about the quiescent equilibrium level, as they are for ordinary catenary-style moorings, where motions above and below the quiescent equilibrium level are more symmetrical. This flag therefore allows much more efficient use of the available interpolation layers for rigid TLP-type structures.
- Item 31: When importing data files for hawser-based CALM systems from CALMsim, characteristics of both buoy and "storage" vessel are contained in the CALMDAT file. At the time of import Catsim assumes and is set up for a "hawser"-type evaluation involving both vessels and the connecting hawser. To carry out a "buoy alone" *single*-vessel analysis (i.e., with tanker and hawser removed from the buoy), tanker and hawser information must be "hidden". To "hide" the hawser, reduce the "Number of mooring legs" and the "Number of distinct mooring leg types" by one and toggle the "Treat last line as hawser" item on Screen 2 to "No". To "hide" the tanker, swap its data for that of the buoy using this option. (All of these actions are reversible.) The necessary buoy draft (and, if "continuous equilibrium analyses are to be carried out, buoy hydrostatic properties) will now be available to Catsim and visible from within the Editor.
- Item 32: The "debug" option, when activated ("on") causes rather unintelligible output to be sent to the Screen during program execution. The principal use of this feature is to aid SeaSoft in determining the cause of program failures. Its activation has no effect on program operation, other than a reduction in execution speed.

```

**** Screen 17: End of Session ****

1) Exit to operating system and update data file
2) Exit to operating system WITHOUT updating data file

3) Execute simulation in interactive mode
4) Execute simulation in silent mode

5) Produce diskfile of input data
6) Produce "WAVEOUT" file containing regular wave kinematics data

7) Import vessel and environment data from an external file
8) Import mooring system data from an external file

(Press <RETURN> to review data.)

Enter number of selection:

```

Screen 17: This is the final Screen image of the Editor.

Item 1: This option will save the current *DAT data file (and, if necessary, produce appropriate *BAK and/or LASTBAK backup files) and exit to the operating system. It is used to "save" an incomplete *DAT data file prior to completion of data entry (to avoid data loss from unexpected power outages, for example).

No error checking is involved in this operation; a save and exit will always be accomplished without further ado.

Be warned, however, that repeated invocations of this option will cause the *original* data file to be lost "off the end" of the backup process as repeated [*DAT -> *BAK -> LASTBAK -> deletion] cascades take place. You should therefore always work on a copy of important data files lest you lose valuable data.

Item 2: Permits exit of the Editor with *no changes* to the current data file; all data modifications made during the current editing session *will be lost*.

Item 3: This option causes simulation execution to proceed with a comprehensive information stream directed to the console. This stream is useful for troubleshooting purposes. This is the same as the "E"xecution item available from any editor page or from the opening screen.

Item 4: This option causes the normal console messages that accompany execution to be written instead to a text file ("Diagnostics.stxt"). Because console output is very CPU-intensive, executions will run to completion substantially faster with this option; batch operations in particular will enjoy a considerable speed increase.

The downside: Should unusual conditions be encountered during simulation, there is no mechanism for user control or intervention. Problematic simulations may therefore terminate prematurely in "silent"

mode. These should be re-run in "interactive" mode because they can often be coaxed to completion with appropriate user response(s) to run-time error conditions.

Item 5: Produces a diskfile named MOORIN.stxt (or SPMIN.stxt, or ...) of all Editor session Screen images for documentation purposes.

Item 7: This option permits importation of vessel and environmental data from any SeaSoft data file. It is particularly useful for importing complex vessels such as Semisubmersibles.

Item 8: This option permits importation of an entire mooring system from any SeaSoft data file.

Notes: The source data file(s) for Items 7 and 8 can be from any simulation, but should have been created by or updated to the same version number as the importing application or the imported data may be corrupted. For example, to import Semisubmersible vessel data from a prehistoric "legacy" Moorsim project, you must first update the legacy MOORDAT (or SEMIDAT) file using the *current* version of Moorsim (or Semisim).

The file selection mechanism is very rudimentary to preserve cross-platform independence: The editor will produce a prompt to which you must supply, in the notation of your operating system, a valid *absolute* or *relative* path to the target file. Some examples:

- *Absolute* path to a file in any directory

C:\SeaSoft\SPM\Proj_1\SEMIDAT	(Windows OS)
HD3:SeaSoft:SPM:Proj_1:SEMIDAT	(Classic Macintosh)
\SeaSoft\SPM\Proj_1\SEMIDAT	(Linux, Mac OS X)

The *relative* path method is simpler and is recommended, especially if the desired import file is in a deeply-buried directory. Place a copy of the target file in your working directory, give it a convenient short name (e.g., "ND" for New Data), and type that short name at the simulation prompt.

Then, for a resident file "ND" in the *working* directory, the *relative* path is simply:

ND	(All Operating Systems)
----	-------------------------

Chapter 5

Output Stream Description

Output Description by Output Section

The following discussion relates to the sample problem output pages presented in Appendix Y and Appendix Z.

The "CATOUT.stxt" File

The first output file produced by Catsim contains the title page and, if requested by the user in the Editor session, a variety of static interpolation table data.

Interpolation Table-Related Output: Section I

This tabular offset information is the source of all static line force versus offset data used in the Simulation. Linear interpolation between table rows defines completely all aspects of line static behavior. Table limits are defined by the user in the Editor session.

Notes:

- Every generic output page in Output Section I is repeated in the output stream a number of times equal to the product of the number of line *types* times the number of *interpolation levels* required. The number of interpolation levels is 1 (if no offsets requiring vertical fairlead translations are requested), 7 (the program default value) or a user-specified value from 3 to 29. For each line type and interpolation level, there are up to four output pages comprising "I. Line Characteristics Summary"; "Ib. Element Endpoint Position Tables" (one for horizontal (X) endpoints and one for vertical (Z) endpoints), and "Ic. Element Endpoint Angle Table". Thus, for example, a system with two line types and seven interpolation levels could produce up to $2 \times 7 \times 4 = 56$ pages of interpolation table data.
- Interpolation levels are numbered upwards, beginning at the *lowest*. Also indicated are (1) the vertical distance from each "level" to the "nominal fairlead level" for the indicated line type and (2) the "vertical separation between endpoints" which is to say the vertical separation between the current interpolation level and anchor. "Nominal fairlead level" is simply the fairlead height associated with the particular line type at the current interpolation layer.
- **Section I** ("Line Characteristics Summary") contains a summary of several useful subline characteristics as a function of fairlead line load. "Top Tension" is *total* tension at the fairlead and anchor respectively; "Horizontal Tension" is the actual independent variable in the table and, in the absence of bottom friction, is the same at all points along the line from anchor to fairlead; "Endpoint Separation" is total *horizontal* distance between fairlead and anchor; "Bottom Length" is the length of line from touchdown to anchor. The sign conventions for the fairlead

and anchor "Line Angles" are: a positive *fairlead* line angle corresponds to a line departing the fairlead in a *downwards* direction, while a positive *anchor* line angle corresponds to a line departing the anchor in an *upwards* direction.

- The "Table Index", displayed in the first column of all Section I tables, links together all the tables for a given interpolation level and line type. For example, "Table Index 3" corresponds to the same physical line state in tables I, Ib and Ic, allowing an association to be made between any two variables even though they do not appear in the same table, such as "Subline Endpoint Positions" (Section Ib) and "Bottom Length" (Section I).
- **Section Ib** ("Element Endpoint Position Table") contains element *endpoint* position. Subline counting begins at the fairlead (i.e., Subline 1 begins at the fairlead and its "endpoint" is at its anchor-ward end.) Should more detailed line position data be needed, individual *uniform* sublimes can be broken up into shorter segments, provided that the maximum allowable number of sublimes per line is not exceeded. The first table in Section Ib comprises horizontal endpoint positions, while the second comprises vertical endpoint positions relative to the fairlead. The sign convention is that positive X values are towards the anchor, while positive Z values are upwards (above the fairleads). Therefore, most "Z" locations have a negative sign.
- **Section Ic** ("Element Endpoint Angle Table") contains element endpoint *angles*. For example, the "T1" angle is the vertical angle (in degrees) at the fairlead end of the *first* subline. A zero angle corresponds to a horizontal tangent and a positive angle represents a tangent line sloping *downwards* towards the anchor.

The "MEANOUT.stxt" File

The second output file produced by Catsim is an "Equilibrium Condition Summary" containing general information on the user-specified zero-offset mooring configuration and, if applicable, system response to user-specified "initial" applied forces and moments.

Equilibrium Condition Summary: Section II

The "Equilibrium Condition Summary" characterizes (1) the user-specified quiescent (zero-offset) condition and in the case of nonzero user-specified initial force, (2) the mean condition at the initial offset. In the event that the specified line tensions, fairlead positions and plan-view departure angles did *not* result in a condition of zero net force and moment on the system, the Simulation will report (1) the user-specified conditions and (2) Simulation-corrected pretensions which *do* produce a true equilibrium condition. If there is also a user-specified initial offset force, the simulation will in this event produce yet a *third* summary using the user-specified offset force to determine a second equilibrium position removed from either the Simulation-revised pretension condition *or* the user-specified pretension condition, depending on the state of user toggle 3 on Screen 14.

The "OFFSETS.stxt" File

The third and final output file produced by Catsim contains requested line load versus offset information summarized in several different ways. First, each of the various *types* of offset (i.e., Rectilinear Lateral Offsets, Yaw Offsets, Oblique Rectilinear Offsets, Oblique Rotational Offsets, Continuous Equilibrium Forcing Offsets and Continuous Equilibrium Torquing Offsets) is given its own output section number for identification. Each requested offset sequence, regardless of offset *type*, produces an output stream satisfying user requests set in the Editor Output Options Screens. The output pages corresponding to different *types* of offset are identical in structure and format and will be described below.

Most Exposed Line Characteristics: This output page is *always* produced, regardless of the selections made in the Editor. It summarizes various force components for the most loaded line as well as total *restoring* force, which *by definition* is the *component* of the total mooring force or moment *opposing* the prescribed offset. In the case of buoy-hawser-tanker systems, this output page is produced in *two* copies, one containing buoy-related data, the other containing hawser-specific data.

Notes on The "Total Restoring Force"

Our definition of the "Total Restoring Force" may at first appear to produce unexpected results for the many "unconventional" offset sequence types accommodated by Catsim. For example, you will be accustomed to a zero initial value of "Total Restoring Force" for rectilinear-lateral offset sequences of the kind most often used in the offshore industry for mooring analyses. This is simply because the *horizontal* component of total mooring force always vanishes at equilibrium, therefore the *component* of mooring force opposing a simple lateral offset in the waterplane will also vanish at the zero offset point (the *total* mooring force, which includes a large vertical component, does *not* vanish, of course). However, once offsets with a *vertical* component are considered it is *not* the case that the net mooring force vanishes at the zero offset point; there is almost always a large net *vertical* mooring force, even at the equilibrium (zero offset) point. This force is of course balanced by hydrostatic adjustments in vessel vertical position to produce an equilibrium in the vertical dimension. Therefore, for *any* offset sequences with a vertical component of motion (for rectilinear Hand of God offsets) or force (for continuous equilibrium force-specified offsets), the "Total Restoring Force" value corresponding to the first (zero offset) point will not vanish. In fact, for a pure *vertical* offset sequence the initial "Total Restoring Force" will be exactly the total vertical component of mooring force at the equilibrium position (see the sample problem output for an example of this). Catsim provides a mechanism for subtracting out this initial force; see the discussion of item 23 on Editor Screen 16. We spell out explicitly what is meant by "Total Restoring Force" for each Catsim offset type below.

- In *rectilinear* Hand of God offset sequences, the "Total Restoring Force" is the *component* of the total mooring force *opposite* the direction of

the rectilinear offset.

- In *rotational* Hand of God offset sequences, the "Total Restoring Moment" is the *component* of the total mooring moment *opposing* the prescribed rotational offset; the "directions" of angular quantities being, as always, defined by the engineering "right-hand rule".
- In "Continuous Equilibrium Forcing" sequences, the "Total Restoring Force" is the component of the total mooring force opposing the *offset* realized by the imposed force (and *not* in this case opposing the specified offsetting *force*; the applied forces and resulting offsets are not in general co-linear in this type of sequence).
- In "Continuous Equilibrium Torquing" sequences, the "Total Restoring Moment" is the component of mooring moment opposing the specified offsetting moment (and *not* in this case opposite in direction to the angular *offset* realized by the imposed moment). (The apparent asymmetry in definition between forces and moments in this regard arises from the inability to assign a direction vector to finite-angle rotations.)
- In the case of buoy-hawser-tanker systems, *two* mandatory "most exposed line" -type output pages are produced, one for the buoy and one for the hawser. On the "buoy" output page, the "Total Restoring Force" column will indicate approximately zero for all buoy offset positions. This is because the net *lateral* force on the buoy *always* vanishes since the horizontal component of hawser force is equal and oppositely directed to the resultant horizontal force from the remaining mooring lines. The "Total Restoring Force" column on the hawser data page contains the horizontal component of the hawser load, which is normally associated with the "offsetting force".

Total Restoring Characteristics and Cross-Coupling Summary: This page breaks down the total mooring force acting on the vessel into force and moment components *relative to the vessel-fixed frame*. Thus the displayed force components are associated with Surge, Sway and Heave, while the displayed moment components are associated with Roll, Pitch and Yaw.

Note

- The "Orthogonal to Offset" column gives the component of *total* mooring force orthogonal to the offset direction in the case of rectilinear Hand of God offset sequences; this component does *not* generally lie in the waterplane. Unfortunately, it is usually the case in conventional reports of this type to quote the *projection* of the orthogonal component *in the waterplane*. Statmoor is a case in point; the same mooring system will produce different values for the two programs in this data column. This column has no meaning for *rotational* offsets and is therefore omitted for both oblique rotational and continuous equilibrium torquing sequences. The "Orthogonal to Offset" values, particularly non-zero values occurring at zero offset, are subject to the same considerations as the "Total Restoring Force" discussed above.

Summary of Continuous Equilibrium Offsets: This page appears only for the "continuous equilibrium-type sequences. It documents vessel translational and rotational adjustments (or "offsets") in all six degrees of freedom required to continuously maintain equilibrium under the specified force and torque conditions. It is, in a way, the inverse of other presentations in Catsim in that it explicitly acknowledges by its format the role of forces (or moments) as the *independent* variables and the role of motions as the *dependent* variables in "continuous equilibrium-type sequences.

Lateral Offset Restoring Characteristics: Section III

The so-called "Lateral" offsets, comprising rectilinear offsets of the vessel in arbitrary directions *in the waterplane*, constitute the first block of offset data in OFFSETDAT.

Notes:

- Vertical force components in this (and *all* other sections) are *signed*. The signs relate to the usual vessel coordinate system with z positive upwards.
- The (possibly multiple) supplemental pages containing mooring line-by-mooring line itemization of line tensions, plan view angles, suspended lengths, etc., are not labelled "Section III"; all output pages sandwiched between Section III and later Section numbers are associated with Section III, as indicated by the offset "type and direction" information given on each page header.
- In the case of the CALM buoy-hawser-tanker evaluation, Section III contains *two* obligatory output pages, one for the hawser alone and one for the buoy. See the general comments above on the "Total Restoring Force" and Appendix Z for more information. In all lateral offset analyses of this type, the independent variable is the *buoy* offset distance. The first table row, corresponding to zero offsetting force, is notable in a hawser analysis. In the first table row (the "zero horizontal force" row), because the hawser has nonzero weight, the tanker attempts to override the buoy, or in reality, to approach as closely as physically possible. Catsim reports this condition as zero buoy offset and zero tanker offset. The second offset row, corresponding to the smallest nonzero horizontal force component, produces a large change in offset for the tanker as the restoring force in the hawser becomes dominated by hawser *compliance* rather than hawser *weight*.

Yaw Offset Restoring Characteristics; Section IV

The so-called "Yaw" offsets comprise rotational offsets about a vertical axis through the cg or mooring centroid. All fairlead motions in response to these offsets are parallel to the waterplane.

Oblique Axis Rotational Offset Characteristics; Section V

These offsets are analogous to the "Yaw" offsets of Section IV, only they are not confined to vertical rotation axes.

Vertical Offset Restoring Characteristics; Section VI

These offsets are a special case of the "Oblique Rectilinear Offsets" of Section VII; they are broken out separately for reasons of convention and convenience.

Oblique Rectilinear Offset Characteristics; Section VII

These offsets are analogous to the "Lateral" offsets of Section III, only they are not confined to motions parallel to the waterplane. They form a superset that includes *all* Section III-type offset sequences.

Continuous Equilibrium Under Specified Forcing; Section VIII

These sequences contain a qualitatively different type of information than any of the other "Hand of God" offset sequences in that they permit vessel motions in response to mooring and hydrostatic forces and moments as the offset sequence develops, maintaining at each offset point an equilibrium between the user-specified force on the one hand and mooring and hydrostatic forces on the other. The offset of the center of gravity and the pitch, roll and yaw angular offsets of the vessel are provided for each equilibrium condition

Continuous Equilibrium Under Specified Torquing; Section IX

These offsets are analogous to those of Section VIII, only they apply to applied *moments* (torques) instead of applied *forces*.

Appendix A

Glossary

added mass	Refers to the enhancement of inertial properties of a body undergoing accelerated motion in a surrounding fluid.
Auto Repeat	A feature permitting rapid input of a long string of equally spaced input variables, such as regular wave periods.
coordinate convention	In this document, x is positive forward, y positive to port (left when facing forward), z positive upwards; origin at vessel baseline directly below the center of gravity.
floating point	Refers to a numerical variable in Fortran which is used and stored in memory in exponential format as opposed to simple integer ("fixed point") format.
global coordinates	Any coordinate system fixed to the earth which provides a suitable reference system for definition of environmental forces and directions. The origin is at the mooring centroid.
GM	The vertical distance between the center of gravity and metacenter. Equal to KM minus KG. Transverse and longitudinal values are associated respectively with KMT and KML.
gyradius	The square root of the ratio between the mass moment of inertia of a body about its center of gravity and its mass. A measure of the angular inertia of a body.
in-plane	Refers to points lying in a vertical aligned with the mean offset direction from the quiescent-condition mooring centroid to the displaced (environmentally-determined) mean mooring centroid.
input file	File produced by the Editor containing input data.
KB, KG, KML, KMT	The vertical positions of the center of buoyancy, center of gravity, and longitudinal and transverse metacenters, all measured from the keel baseline.
kgw	Kilogram weight; a unit of weight equal to 1/1000 of a metric ton.
kip	The unit of weight used when English units are selected. Equal to 1000 pounds.
low-frequency	In this manual this refers to oscillations whose period is much greater than periods associated with naturally occurring waves. In particular, the natural periods of oscillation of

	moored vessels fall in this category, these being typically from one to ten minutes.
Lpp, LBP	The "length between perpendiculars" is a common measure of vessel length that is generally quite close to the length of the waterline at maximum draft condition. It is usually about 5% less than the overall vessel length (LOA).
machine-readable	Data files which remain in machine-encoded format and which cannot be easily interpreted without a computer program equipped to display them, such as the Editor.
mainframe	A large data processing machine with special floating point mathematics processors, high speed circuitry and core addressing capabilities measured in hundreds of megabytes.
metric ton	The unit of weight used when metric units are selected. Equal to the weight of 1000 kilograms at a nominal gravitational acceleration of 9.8 meters/second**2, or roughly 2205 pounds.
moulded depth	For practical purposes, this is the profile height of the hull from keel to main deck level; it is by definition draft plus freeboard in this document.
N.A.	Not Applicable.
natural period	The period with which a vessel will oscillate in a particular degree of freedom, once displaced from equilibrium. For unmoored vessels, this only applies to degrees of freedom (roll, pitch, heave) which experience static restoring forces upon displacement from equilibrium. For highly asymmetric vessels, well-defined natural periods for roll, pitch and heave may not exist due to coupling between the degrees of freedom.
paging	The facility in the Editor which permits progress through the input file in either the forward (with a "carriage return") or backward (by inputting a "B") directions.
quasi-static	This refers to dynamic phenomena which occur on a time scale which is so long that the system is at each instant very near to an equilibrium configuration; in particular acceleration, damping and other quantities which depend explicitly upon time derivatives of dynamical variables can be considered negligible.
Simulation Draft	The mean draft associated with the desired partial loading condition for the target vessel.
toggle	This is a generic mechanism used to change an input variable having two possible values, such as metric versus English units specification.

vessel-fixed	This refers, in particular, to a coordinate system fixed with respect to the vessel with x-axis forward, y-axis to port and z-axis vertical. The origin of this system is generally taken to be at keel level below the plan-view centroid of the waterplane area.
waterplane coefficient	The waterplane area of a vessel at a given waterline divided by the product of its waterline beam and length; a measure of the rectangularity of the waterplane (symbolized by C_{wp}).

Appendix B

Sample Problem

As a tutorial aid in the use of Catsim, this appendix includes the data required to carry out an evaluation of static mooring loads on a typical CALM buoy with and without a hawser-moored tanker. This sample problem uses the same vessels and mooring system as the CALMsim sample problem in the CALMsim manual supplement, which should be consulted for additional details. The data required for Catsim comprises only a subset of the information required for execution of CALMsim; the required mooring system information is duplicated here for convenience. The output streams appear in Appendices Y & Z.

Input Data

Buoy Particulars:

1. Displacement.....	412.0 metric tons
2. Length	12.0 meters
3. Beam	12.0 meters
4. Draft	3.50 meters
5. KMT.....	4.3 meters
6. KML.....	4.3 meters
7. VKB	1.8 meters
8. VKG.....	2.5 meters
9. Water plane area.....	113.1 square meters

Buoy Fairlead Particulars:

1. Number of lines.....	6
2. Maximum line load	750 metric tons
3. Fairlead locations	7.15 meters (radial)
4. Height of fairlead attachment.....	at keel level
5. Height of hawser attachment.....	6.6 meters
6. Water depth	35 meters

Buoy Mooring Line Particulars:

- 6x457 meters of 102 mm ORQ chain.
- Lines laid out in a regular radial array with 60 degrees between adjacent legs; one leg aligned with global 0 degrees.
- Uniform pretension of 15.6 metric tons.
- SeaSoft default line physical properties.

Tanker Particulars:

1. Draft 21.8 meters
2. Height of hawser attachment..... 30 meters

Hawser Particulars:

- 2 meters of 102 mm ORQ chafe chain at tanker.
- 50 meters of 240 mm diameter Nylon hawser to buoy.
- SeaSoft default line physical properties.

Offset Particulars:

- Buoy-Tanker system: offset sequences on and between buoy mooring legs.
- Buoy alone: A complete set of demonstration offset sequences.

Catsim Screen Images of Imported CALMDAT File

Upon initial import of the CALMDAT file into Catsim, both hawser and tanker data required for simulation of the composite system is present in the data file and the Screen 2 image is as shown below. The transition from buoy-hawser-tanker composite to the buoy-alone system of Chapter 5 and elsewhere is accomplished in four steps (see also pps 7 and 35):

- Reduce the "Number of mooring legs" *and* the "Number of distinct mooring leg types" by one. This will "hide" the hawser data from Catsim, although the data remains in the file and *is not lost*. It may be recovered by reversing this procedure.
- Toggle the "Treat LAST line type/number as a hawser" flag to "No".
- Exchange the buoy and tanker draft and hydrostatic data by using the "Swap tanker, buoy data from CALMsim import file" facility on the second Catsim "Output Options" Screen (see page 35):

```

**** Screen 2: General Mooring Information <<INCLUDES hawser>> ****
++> NOTE: Line number 7 & line type B comprise Hawser data

1) Number of mooring legs (Max 49) ..... 7
2) Number of distinct mooring leg types (Max 49) ..... 2
3) Maximum interpolation table horizontal load ..... 750.00 metric tons
4) Smallest nonzero horizontal load ..... .10 metric tons
5) Number of points in interpolation table(s) ..... 30
6) Mean line profile determined by ..... line tension
7) Modify individual values of line tension

8) Default bottom friction coefficient ..... .00
9) Treat LAST line type/number as a hawser ..... Yes
10) Vessel draft ..... 21.80 meters
11) Buoy draft ..... 3.50 meters

16) Reset default Anchor depth ..... 35.00 meters
17) Specify anchor depths individually ..... Yes
18) Default bottom boundary is "transparent" ..... No
19) First buoyant element stays at or below waterline: No

```

Note that both "vessel" and buoy drafts are displayed. Hawser data appears as any other mooring line in the data file as indicated on Screens 3 and 4B below.

```

**** Screen 3: More General Mooring Information <<INCLUDES hawser>> ****
>>> NOTE: Line number 7 & line type B comprise Hawser data

1) Number of mooring legs associated with each type --
   6 in Type A      1 in Type B

2) Number of sublimes associated with each type (max 10) --
   1 in Type A      2 in Type B

3) Edit fairlead positions
4) Edit plan-view line departure angles

5) Edit mooring moment evaluation center (on buoy)
6) Edit hawser attachment point on storage vessel

7) Tanker heading in quiescent conditions:      .00 Degrees
8) <Buoy> heading in quiescent conditions:      .00 Degrees

10) Number of excluded or broken lines: 0

```

Note that when hawser data is present, this fact is flagged on each mooring data screen; hawser data appears as for any other line. Note that tanker attachment point must be specified for the buoy-hawser-tanker problem.

```

***** Screen 4B: Subline Specifics *****
("C", "D", "I", "X" to Copy, Delete, Insert, Exchange)

---> Subline attached to buoy

1) Hawser comprising line type B (type 2)
2) Subline number: 1 of 2

3) Subline composition ..... Nylon
4) Subline length ..... 50.00 meters
5) Subline outside diameter ..... 240.00 millimeters
6) Immersed weight/unit length ..... 38.59 kgw/meter
7) Dry weight/unit length ..... 38.59 kgw/meter
8) Breaking strength ..... 972.29 metric tons
9) Added mass coefficient ..... 1.00
10) Transverse drag coefficient ..... 2.50

11) Take elastic properties from an input file? .. No
12) Compliance coefficient #1 (alpha1) ..... 0.834E-03 (m.ton)**-1
13) Compliance coefficient #2 (alpha2) ..... -0.618E-06 (m.ton)**-2
14) Compliance coefficient #3 (alpha3) ..... 0.168E-09 (m.ton)**-3

20) Type B line numbers: 7,

21) >> HELP << for subline physical property estimates

```

```

***** Screen 4B: Subline Specifics *****
("C", "D", "I", "X" to Copy, Delete, Insert, Exchange)

---> Subline attached to tanker

1) Hawser comprising line type B (type 2)
2) Subline number: 2 of 2

3) Subline composition ..... Chain
4) Subline length ..... 2.00 meters
5) Subline outside diameter ..... 102.00 millimeters
6) Immersed weight/unit length ..... 240.33 kgw/meter
7) Dry weight/unit length ..... 228.32 kgw/meter
8) Breaking strength ..... 788.75 metric tons
9) Added mass coefficient ..... 1.00
10) Transverse drag coefficient ..... 1.00

11) Take elastic properties from an input file? .. No
12) Compliance coefficient #1 (alpha1) ..... 0.120E-04 (m.ton)**-1
13) Compliance coefficient #2 (alpha2) ..... 0.000E+00 (m.ton)**-2
14) Compliance coefficient #3 (alpha3) ..... 0.000E+00 (m.ton)**-3

21) >> HELP << for subline physical property estimates

```

The hawser definition windows are identified as such and no "anchor depth" data is requested, this being supplied by the tanker attachment points specified.

Appendix C

File Management

File Requirements

As discussed earlier, the Editor produces an unformatted data file called CATDAT containing particulars of a given simulation including vessel, site and environmental characteristics. Once a satisfactory CATDAT file has been produced, as determined by satisfactory output from Catsim, this file should be archived for safekeeping by giving it a more meaningful name and copying it to a specially reserved archive area of the hard disc. A copy of the archived data file can then, at any later time, be *copied* (not *moved*) back to the Catsim work area, renamed to CATDAT, and reviewed and/or reworked as necessary.

Final output from production simulation executions, *including* the CATIN text file (generated automatically at program execution or by the "Produce disk file of input data" option on the final page of the Editor), should normally be archived along with the associated CATDAT file. The entire input/output package can be compressed with any of a number of widely available compression and archival utilities and saved for later reference.

Importance of Archiving CATIN.stxt

It is *essential* to archive, along with the binary CATDAT file, the CATIN.stxt formatted data file produced with the "Produce diskfile of input data" option on the last editor screen. This is important because it is impossible to view the data in binary files without the Editor. Although it is SeaSoft policy to provide upgrade paths for data files as the Simulation's data structures change over time, these changes may in unusual circumstances make reading very old CATDAT files problematic. In such cases it may be advantageous to create a new data file manually from a CATIN archive.

Appendix D

Auxiliary Data File Formats

A few of the built-in SeaSoft data structures and models can be superseded with user-supplied information in tabular ASCII (i.e., text) format. Available user-supplied modeling constructs for Catsim comprise:

Slender-body elastic properties	(LINE_STRAIN_DB.txt)
Oblique "Hand of God" offset particulars	(INPUTOFF.txt)

General Comments

These user-defined input capabilities can be combined without restriction. The naming conventions are meant to be self-descriptive; the ".txt" suffix indicates they are *input* files, distinguished from *output* files which have a ".stxt" suffix.

The required user data files can be produced "by hand" using any text editor or word processor, or from electronically copied tabular output from any source. The data can be in any Fortran-compatible floating-point format, for example either ".123E-2" or ".00123", with any number of significant digits. Refer to the various sample data files given below (constructed to be unrealistically small to minimize manual display space).

- Notes:**
- The data files *must* contain purely ASCII text characters (i.e., no formatting). The files are record-based, with one data record per line. Each line must end with the End Of Line (EOL) character(s) appropriate to the operating system being used. Normally, this will happen automatically provided the text file is prepared using tools on the computing platform hosting the simulation. Problems can arise in moving these data files across platforms (such as from Windows to Macintosh or Linux). In that event, the EOL markers will in general need to be modified to match those of the host platform using standard text-processing tools and procedures.
 - The data files must reside in the working directory (i.e., the same directory as the CATDAT file in use).

LINE_STRAIN_DB.txt

This data file can be used to provide elastic properties for any or all subline elements in the mooring system. See comments on page 17 ff.

Format of the *LINE_STRAIN_DB.txt* Data File

File structure: A repeating block of data, one block for each (type, subline) for which user data is to be specified.

The format of these files is reflected in the following descriptive code snippet.

```
C Begin Snippet
      IMPLICIT NONE
      INTEGER NBLOKS, NVALS(NBLOKS), ITYPE(NBLOKS), ISUBLINE(NBLOKS)
      REAL TENS_ARRAY(NVALS,NBLOKS), STRAIN_ARRAY(NVALS,NBLOKS)
C
C NBLOKS      - Total number of user-specified tension-elongation blocks
C NVALS      - Total number data values in the active block
C IVAL       - Local data value index
C LTYPE      - Line Type Index Array
C LSUBLINE   - Subline Index Array
C TENS_ARRAY - Array of tension values
C STRAIN_ARRAY - Array of elongation (AKA strain) values
C
C Read LINE_STRAIN_DB
C
      DO 50 IBLOK = 1, NBLOKS
      READ (UNIT,*) NVALS(IBLOK),LTYPE(IBLOK),LSUBLINE(IBLOK)  !Block properties
      DO 50 IVAL = 1,NVALS(IBLOK)                               !Block data input
      READ (UNIT,*) TENS_ARRAY(IVAL,IBLOK), STRAIN_ARRAY(IVAL,IBLOK)
50    CONTINUE
C End Snippet
```

LINE_STRAIN_DB: General Usage Notes

A simple example data block, suitable for a linear tension-elongation (t-e) relationship [$e(t) = .001*t$] follows immediately below

```
>>> Begin sample data block
      2,1,3
      0.00, 0.00
      500.0,0.50
>>> End sample data block
```

The first row (AKA "record") in each data block is the number of (t,e) data pairs in the block (= 2 in this example) followed by the line type (= 1) and the subline number (= 3) to which the block relates. The (tension, elongation) data follows immediately (2 rows of (t,e) pairs in this case).

Multiple data blocks, one block per subline, can be concatenated within the database file.

Data Block Notes:

- The first (t,e) value must be (0,0).
- The tension range should span at least 1.5 times the (user-specified) "Maximum interpolation table horizontal load" value on page 12.
- Numeric values can be tab, space or comma delimited.
- The maximum supported number of (t,e) pairs in each block is indicated in a note on the editor page, e.g.:

[You must provide a maximum of 30 (tension, elongation) values for (type, subline) = (1,3) in the LINE_STRAIN_DB.txt database file.]

- The file name must be as indicated on the editor page note ("LINE_STRAIN_DB.txt" in this example; the file name may vary across operating systems).
- (type, subline) data blocks in the file must occur in the same sequence as their appearance in the editor, with no intervening blank lines.
- The file must terminate with at least one blank line.
- A LINE_STRAIN_DB.txt file containing user-specified tension-elongation data for three sublimes (three data blocks) might look like:

```
>>> Begin LINE_STRAIN_DB.txt example (data is tab, comma or space delimited)
  2,1,1      ! First block with two data points for (type,subline) = (1,1)
  0.00, 0.00 ! First data point
  500.0,0.50 ! Second data point
  3,1,3      ! Second block with three data points for (type,subline) = (1,3)
  0.00, 0.00 ! First data point
  250.0,0.25 ! Second data point
  500.0,0.50 ! Third data point
  3,2,1      ! Third block with three data points for (type,subline) = (2,1)
  0.00, 0.00 ! First data point
  250.0,0.20 ! Second data point
  500.0,0.40 ! Third data point

>>> End LINE_STRAIN_DB example (note blank line terminates data)
```

INPUTOFF.txt

You may specify an arbitrary and completely generalized array of c.g. offsets and vessel orientations (or, "offset 6-vectors") by preparing a text file named "INPUTOFF.txt". See page 24 ff.

Description of the 6-Vector

The 6-vector structure comprises (Gx,Gy,Gz,Rx,Ry,Rz). The first three values (Gx,Gy,Gz) are the global components of the desired CG offset vector and the last three values (Rx,Ry,Rz) are the components of the desired (finite angle) rotation vector. To obtain (Rx,Ry,Rz), you need to prepare a three-vector whose *magnitude* (i.e., length) is the desired rotation angle, and whose *direction* is the desired axis of rotation (assuming the right-hand rule). Thus, (Rx,Ry,Rz) = (1,1,1) would correspond to a clockwise rotation of magnitude $\sqrt{3} = 1.73\dots$ radians (*not* degrees). The rotation *axis* comprises the shaft of an "arrow" pointing from (Gx,Gy,Gz) = (0,0,0) to (Gx,Gy,Gz) = (1,1,1).

Rotation Origin

The desired vessel-bound rotation origin (Vx,Vy,Vz) must be specified; see item 8 and discussion on page 24 ff. If item 8 is not visible, set a nonzero number of oblique rotational axes in item 5; this can then be re-set to zero, if desired, after item 8 is appropriately adjusted.

Format of the INPUTOFF.txt Data File

File structure: An initial record indicating the number of offset sequences ("NSEQ") contained in the file, followed by NSEQ repeating blocks of data, one block for each offset sequence. The format of this file is reflected in the following descriptive code snippet.

```
C  Begin Snippet
      IMPLICIT NONE
      INTEGER NSEQ,NOFF(NSEQ)
      REAL SIXVEC(6,NOFF(NSEQ),NSEQ)
C
C  NSEQ          - Total number of user-specified sequences
C  NOFF          - Total number of offset values per sequence
C  ISEQ         - Sequence index
C  IOFF         - Offset index
C
C  Read INPUTOFF.txt
C
C      READ (UNIT,*) NSEQ
C      DO 50 ISEQ = 1, NSEQ
C          READ (UNIT,*) NOFF(ISEQ)
C          DO 50 IOFF = 1,NOFF(ISEQ)
C              READ (UNIT,*) (SIXVEC(I,IOFF,ISEQ),I=1,6)
50      CONTINUE
C  End Snippet
```

INPUTOFF: General Usage Notes

A simple two-block data file (two generalized offset sequences of 6-vectors) follows:

```
>>> Begin simple two-block data file
  2
  3
  0.0    0.0    0.0    0.1    0.1    0.0
  1.0    0.0    0.0    0.2    0.2    0.0
  2.0    0.0    0.0    0.3    0.3    0.0
  4
  0.0    3.0    1.0    0.1    0.1    0.1
  0.0    2.0    2.0    0.1    0.1    0.1
  0.0    1.0    3.0    0.1    0.1    0.1
  0.0    0.0    4.0    0.1    0.1    0.1

>>> End sample data file
```

The first record value (2 in this case) contains the number of sequences (NSEQ) in the file. There is no limit to the number of distinct sequences. The remaining records form a sequence of blocks structured as follows:

The first row in each data block is the number of offsets represented in the block (3 in block one and 4 in block 2 of this example). The *limit* on the number of offsets NOFF in each sequence is 50. The offset 6-vector data follows immediately (3 or 4 rows of 6 values each for the blocks in this case).

Miscellaneous Notes:

- The file name must be "INPUTOFF.txt" and must be in the same directory as CATDAT.
- Numeric values can be tab, space or comma delimited.
- Any suitable floating point notation can be used for the 6-vector components.
- The file must terminate with at least one blank line.

Appendix Y

Buoy Alone Output

This appendix contains output generated by Catsim as a result of a simulation execution using input data presented in Appendix B and Chapter 5 for the "buoy alone" case. Note that the output depicted here *is not complete*. Interpolation levels 3 through 7 have been omitted to reduce output volume.

Appendix Z

Sample Problem Output

This appendix contains output generated by Catsim as a result of a simulation execution using input data presented in Appendix B for the composite buoy-hawser-tanker case.

SeaSoft Systems Simulation Library

Volume 8

Catenary-Elastic Mooring Statics Calculator

 Catsim Version 5.11

Copyright (C) 2005
 By SeaSoft Systems

Sample Problem: Catsim support of CALM installation
 Buoy-alone configuration

Executed at 10:46 on 4/5/05

**
 ***** I. Line Characteristics Summary *****
 **

>>> Interpolation level 1 for line type A of 1 type(s)
 Vertical distance to nominal fairlead 14.00 m.
 Vertical separation between endpoints 17.50 m.

- Segment - Type	Length (m.)	Nominal Diameter (mm)	Submerged Weight (kgw/m.)	---- Elastic Coefficients ----		
				Alpha 1 (m.ton** ⁻¹)	Alpha 2 (m.ton** ⁻²)	Alpha 3 (m.ton** ⁻³)
1 Chain	457.00	102.00	208.83	0.120E-04	0.000E+00	0.000E+00

Table Index	Top	Anchor	Horizontal	-- Line angle --		Endpoint Separation (m.)	Bottom Length (m.)
	Tension (m.ton)	Tension (m.ton)	Tension (m.ton)	Top (deg)	Anchor (deg)		
1	3.65	.00	.00	90.0	.0	439.50	439.50
2	3.75	.10	.10	88.5	.0	441.10	439.03
3	3.79	.14	.14	87.9	.0	441.50	438.85
4	3.84	.19	.19	87.2	.0	441.97	438.62
5	3.91	.26	.26	86.2	.0	442.54	438.30
6	4.01	.36	.36	84.9	.0	443.19	437.87
7	4.15	.49	.49	83.2	.0	443.93	437.29
8	4.33	.68	.68	81.0	.0	444.76	436.52
9	4.59	.93	.93	78.3	.0	445.66	435.51
10	4.93	1.28	1.28	75.0	.0	446.60	434.19
11	5.41	1.76	1.76	71.0	.0	447.57	432.49
12	6.08	2.42	2.42	66.5	.0	448.54	430.33
13	6.98	3.33	3.33	61.5	.0	449.49	427.62
14	8.23	4.58	4.58	56.2	.0	450.39	424.26
15	9.95	6.30	6.30	50.7	.0	451.23	420.13
16	12.31	8.66	8.66	45.3	.0	451.99	415.12
17	15.56	11.91	11.91	40.1	.0	452.69	409.08
18	20.03	16.38	16.38	35.2	.0	453.32	401.84
19	26.18	22.53	22.53	30.6	.0	453.88	393.23
20	34.64	30.98	30.98	26.6	.0	454.39	383.00
21	46.26	42.61	42.61	22.9	.0	454.85	370.91
22	62.25	58.60	58.60	19.7	.0	455.28	356.65
23	84.24	80.59	80.59	16.9	.0	455.70	339.86
24	114.49	110.84	110.84	14.5	.0	456.12	320.11
25	156.08	152.44	152.44	12.4	.0	456.57	296.90
26	213.29	209.64	209.64	10.6	.0	457.07	269.66
27	291.96	288.32	288.32	9.1	.0	457.66	237.69
28	400.16	396.53	396.53	7.7	.0	458.39	200.18
29	548.97	545.34	545.34	6.6	.0	459.33	156.18
30	753.62	750.00	750.00	5.6	.0	460.55	104.56

**
 ***** I. Line Characteristics Summary *****
 **

>>> Interpolation level 2 for line type A of 1 type(s)
 Vertical distance to nominal fairlead 9.33 m.
 Vertical separation between endpoints 22.17 m.

- Segment - Type	Length (m.)	Nominal Diameter (mm)	Submerged Weight (kgw/m.)	---- Elastic Coefficients ----		
				Alpha 1 (m.ton**-1)	Alpha 2 (m.ton**-2)	Alpha 3 (m.ton**-3)
1 Chain	457.00	102.00	208.83	0.120E-04	0.000E+00	0.000E+00

Table Index	Top Tension (m.ton)	Anchor Tension (m.ton)	Horizontal Tension (m.ton)	-- Line angle --		Endpoint Separation (m.)	Bottom Length (m.)
				Top (deg)	Anchor (deg)		
1	4.63	.00	.00	90.0	.0	434.83	434.83
2	4.73	.10	.10	88.8	.0	436.54	434.36
3	4.77	.14	.14	88.3	.0	436.98	434.19
4	4.82	.19	.19	87.8	.0	437.51	433.95
5	4.89	.26	.26	87.0	.0	438.14	433.62
6	4.99	.36	.36	85.9	.0	438.88	433.18
7	5.12	.49	.49	84.5	.0	439.74	432.59
8	5.31	.68	.68	82.7	.0	440.71	431.80
9	5.56	.93	.93	80.4	.0	441.78	430.76
10	5.91	1.28	1.28	77.5	.0	442.93	429.38
11	6.39	1.76	1.76	74.0	.0	444.14	427.60
12	7.05	2.42	2.42	69.9	.0	445.38	425.31
13	7.96	3.33	3.33	65.3	.0	446.60	422.40
14	9.21	4.58	4.58	60.2	.0	447.79	418.77
15	10.93	6.30	6.30	54.8	.0	448.91	414.28
16	13.29	8.66	8.66	49.3	.0	449.95	408.78
17	16.54	11.91	11.91	43.9	.0	450.90	402.11
18	21.01	16.38	16.38	38.8	.0	451.76	394.09
19	27.16	22.53	22.53	33.9	.0	452.53	384.49
20	35.61	30.98	30.98	29.5	.0	453.22	373.08
21	47.24	42.61	42.61	25.6	.0	453.85	359.55
22	63.23	58.60	58.60	22.1	.0	454.42	343.57
23	85.22	80.59	80.59	19.0	.0	454.96	324.71
24	115.46	110.84	110.84	16.3	.0	455.49	302.52
25	157.06	152.44	152.44	13.9	.0	456.03	276.42
26	214.26	209.64	209.64	11.9	.0	456.61	245.76
27	292.93	288.32	288.32	10.2	.0	457.27	209.77
28	401.13	396.53	396.53	8.7	.0	458.06	167.51
29	549.94	545.34	545.34	7.4	.0	459.04	117.92
30	754.59	750.00	750.00	6.3	.0	460.31	59.69

**
 ***** I. Line Characteristics Summary *****
 **

>>> Interpolation level 3 for line type A of 1 type(s)
 Vertical distance to nominal fairlead 4.67 m.
 Vertical separation between endpoints 26.83 m.

- Segment - Type	Length (m.)	Nominal Diameter (mm)	Submerged Weight (kgw/m.)	---- Elastic Coefficients ----		
				Alpha 1 (m.ton**-1)	Alpha 2 (m.ton**-2)	Alpha 3 (m.ton**-3)
1 Chain	457.00	102.00	208.83	0.120E-04	0.000E+00	0.000E+00

Table Index	Top Tension (m.ton)	Anchor Tension (m.ton)	Horizontal Tension (m.ton)	-- Line angle --		Endpoint Separation (m.)	Bottom Length (m.)
				Top (deg)	Anchor (deg)		
1	5.60	.00	.00	90.0	.0	430.17	430.17
2	5.70	.10	.10	89.0	.0	431.96	429.69
3	5.74	.14	.14	88.6	.0	432.43	429.52
4	5.79	.19	.19	88.1	.0	433.00	429.28
5	5.86	.26	.26	87.5	.0	433.69	428.95
6	5.96	.36	.36	86.6	.0	434.51	428.51
7	6.10	.49	.49	85.4	.0	435.47	427.91
8	6.28	.68	.68	83.8	.0	436.56	427.11
9	6.53	.93	.93	81.8	.0	437.79	426.04
10	6.88	1.28	1.28	79.3	.0	439.13	424.62
11	7.36	1.76	1.76	76.2	.0	440.55	422.77
12	8.02	2.42	2.42	72.4	.0	442.03	420.38
13	8.93	3.33	3.33	68.1	.0	443.53	417.33
14	10.18	4.58	4.58	63.3	.0	444.99	413.47
15	11.90	6.30	6.30	58.1	.0	446.40	408.68
16	14.26	8.66	8.66	52.6	.0	447.72	402.77
17	17.51	11.91	11.91	47.1	.0	448.94	395.57
18	21.98	16.38	16.38	41.8	.0	450.04	386.87
19	28.13	22.53	22.53	36.8	.0	451.04	376.44
20	36.58	30.98	30.98	32.1	.0	451.93	363.98
21	48.21	42.61	42.61	27.9	.0	452.74	349.18
22	64.20	58.60	58.60	24.1	.0	453.47	331.67
23	86.19	80.59	80.59	20.8	.0	454.15	310.98
24	116.43	110.84	110.84	17.8	.0	454.79	286.61
25	158.03	152.44	152.44	15.3	.0	455.43	257.93
26	215.23	209.64	209.64	13.1	.0	456.10	224.21
27	293.90	288.32	288.32	11.2	.0	456.83	184.60
28	402.10	396.53	396.53	9.6	.0	457.69	138.08
29	550.91	545.34	545.34	8.2	.0	458.73	83.46
30	755.55	750.00	750.00	7.0	.0	460.04	19.32

**
 ***** I. Line Characteristics Summary *****
 **

>>> Interpolation level 4 for line type A of 1 type(s)
 Vertical distance to nominal fairlead .00 m.
 Vertical separation between endpoints 31.50 m.

Segment Type	Length (m.)	Nominal Diameter (mm)	Submerged Weight (kgw/m.)	Elastic Coefficients		
				Alpha 1 (m.ton**-1)	Alpha 2 (m.ton**-2)	Alpha 3 (m.ton**-3)
1 Chain	457.00	102.00	208.83	0.120E-04	0.000E+00	0.000E+00

Table Index	Top Tension (m.ton)	Anchor Tension (m.ton)	Horizontal Tension (m.ton)	Line angle		Endpoint Separation (m.)	Bottom Length (m.)
				Top (deg)	Anchor (deg)		
1	6.58	.00	.00	90.0	.0	425.50	425.50
2	6.68	.10	.10	89.1	.0	427.37	425.03
3	6.72	.14	.14	88.8	.0	427.87	424.85
4	6.77	.19	.19	88.4	.0	428.48	424.61
5	6.84	.26	.26	87.8	.0	429.22	424.28
6	6.94	.36	.36	87.0	.0	430.10	423.83
7	7.07	.49	.49	86.0	.0	431.14	423.23
8	7.25	.68	.68	84.6	.0	432.34	422.42
9	7.51	.93	.93	82.9	.0	433.70	421.33
10	7.86	1.28	1.28	80.6	.0	435.21	419.88
11	8.34	1.76	1.76	77.8	.0	436.84	417.98
12	9.00	2.42	2.42	74.4	.0	438.55	415.51
13	9.91	3.33	3.33	70.4	.0	440.30	412.34
14	11.16	4.58	4.58	65.8	.0	442.05	408.31
15	12.87	6.30	6.30	60.7	.0	443.74	403.26
16	15.24	8.66	8.66	55.4	.0	445.34	397.01
17	18.49	11.91	11.91	49.9	.0	446.83	389.35
18	22.96	16.38	16.38	44.5	.0	448.20	380.05
19	29.10	22.53	22.53	39.3	.0	449.43	368.86
20	37.56	30.98	30.98	34.4	.0	450.54	355.47
21	49.18	42.61	42.61	30.0	.0	451.53	339.54
22	65.17	58.60	58.60	26.0	.0	452.43	320.64
23	87.16	80.59	80.59	22.4	.0	453.26	298.30
24	117.41	110.84	110.84	19.3	.0	454.03	271.94
25	159.00	152.44	152.44	16.5	.0	454.78	240.90
26	216.20	209.64	209.64	14.2	.0	455.54	204.39
27	294.88	288.32	288.32	12.1	.0	456.36	161.48
28	403.07	396.53	396.53	10.3	.0	457.28	111.07
29	551.87	545.34	545.34	8.8	.0	458.38	51.85
30	756.53	750.01	750.00	7.5	.3	459.75	.00

**
 ***** I. Line Characteristics Summary *****
 **

>>> Interpolation level 5 for line type A of 1 type(s)
 Vertical distance to nominal fairlead -4.67 m.
 Vertical separation between endpoints 36.17 m.

Segment Type	Length (m.)	Nominal Diameter (mm)	Submerged Weight (kgw/m.)	Elastic Coefficients		
				Alpha 1 (m.ton**-1)	Alpha 2 (m.ton**-2)	Alpha 3 (m.ton**-3)
1 Chain	457.00	102.00	208.83	0.120E-04	0.000E+00	0.000E+00

Table Index	Top Tension (m.ton)	Anchor Tension (m.ton)	Horizontal Tension (m.ton)	Line angle		Endpoint Separation (m.)	Bottom Length (m.)
				Top (deg)	Anchor (deg)		
1	7.55	.00	.00	90.0	.0	420.83	420.83
2	7.65	.10	.10	89.3	.0	422.77	420.36
3	7.69	.14	.14	89.0	.0	423.29	420.18
4	7.74	.19	.19	88.6	.0	423.93	419.94
5	7.81	.26	.26	88.1	.0	424.71	419.61
6	7.91	.36	.36	87.4	.0	425.65	419.16
7	8.04	.49	.49	86.5	.0	426.77	418.55
8	8.23	.68	.68	85.3	.0	428.07	417.73
9	8.48	.93	.93	83.7	.0	429.55	416.63
10	8.83	1.28	1.28	81.7	.0	431.21	415.16
11	9.31	1.76	1.76	79.1	.0	433.03	413.22
12	9.97	2.42	2.42	76.0	.0	434.96	410.68
13	10.88	3.33	3.33	72.2	.0	436.96	407.41
14	12.13	4.58	4.58	67.8	.0	438.97	403.23
15	13.85	6.30	6.30	63.0	.0	440.94	397.97
16	16.21	8.66	8.66	57.7	.0	442.83	391.41
17	19.46	11.91	11.91	52.3	.0	444.60	383.35
18	23.93	16.38	16.38	46.8	.0	446.23	373.53
19	30.88	22.53	22.53	41.5	.0	447.71	361.66
20	38.53	30.98	30.98	36.5	.0	449.05	347.43
21	50.16	42.61	42.61	31.8	.0	450.24	330.45
22	66.15	58.60	58.60	27.6	.0	451.32	310.29
23	88.14	80.59	80.59	23.9	.0	452.30	286.42
24	118.38	110.84	110.84	20.6	.0	453.21	258.24
25	159.97	152.44	152.44	17.7	.0	454.08	225.02
26	217.18	209.64	209.64	15.1	.0	454.95	185.93
27	295.85	288.32	288.32	13.0	.0	455.85	139.97
28	404.04	396.53	396.53	11.1	.0	456.85	85.95
29	552.84	545.34	545.34	9.5	.0	458.01	22.47
30	757.57	750.09	750.00	8.1	.9	459.41	.00

**
 ***** I. Line Characteristics Summary *****
 **

>>> Interpolation level 6 for line type A of 1 type(s)
 Vertical distance to nominal fairlead -9.33 m.
 Vertical separation between endpoints 40.83 m.

- Segment - Type	Length (m.)	Nominal Diameter (mm)	Submerged Weight (kgw/m.)	---- Elastic Coefficients ----		
				Alpha 1 (m.ton**-1)	Alpha 2 (m.ton**-2)	Alpha 3 (m.ton**-3)
1 Chain	457.00	102.00	208.83	0.120E-04	0.000E+00	0.000E+00

Table Index	Top	Anchor	Horizontal	-- Line angle --		Endpoint Separation (m.)	Bottom Length (m.)
	Tension (m.ton)	Tension (m.ton)	Tension (m.ton)	Top (deg)	Anchor (deg)		
1	8.53	.00	.00	90.0	.0	416.17	416.17
2	8.63	.10	.10	89.3	.0	418.16	415.69
3	8.66	.14	.14	89.1	.0	418.70	415.52
4	8.72	.19	.19	88.8	.0	419.37	415.27
5	8.79	.26	.26	88.3	.0	420.19	414.94
6	8.88	.36	.36	87.7	.0	421.18	414.49
7	9.02	.49	.49	86.9	.0	422.36	413.88
8	9.20	.68	.68	85.8	.0	423.75	413.05
9	9.46	.93	.93	84.4	.0	425.35	411.94
10	9.81	1.28	1.28	82.5	.0	427.15	410.45
11	10.29	1.76	1.76	80.1	.0	429.14	408.48
12	10.95	2.42	2.42	77.2	.0	431.27	405.89
13	11.86	3.33	3.33	73.7	.0	433.50	402.53
14	13.11	4.58	4.58	69.6	.0	435.78	398.22
15	14.82	6.30	6.30	64.9	.0	438.03	392.77
16	17.19	8.66	8.66	59.7	.0	440.20	385.96
17	20.44	11.91	11.91	54.4	.0	442.26	377.53
18	24.91	16.38	16.38	48.9	.0	444.16	367.24
19	31.05	22.53	22.53	43.5	.0	445.90	354.76
20	39.51	30.98	30.98	38.3	.0	447.47	339.75
21	51.13	42.61	42.61	33.6	.0	448.88	321.82
22	67.12	58.60	58.60	29.2	.0	450.14	300.48
23	89.11	80.59	80.59	25.3	.0	451.29	275.20
24	119.35	110.84	110.84	21.8	.0	452.34	245.32
25	160.95	152.44	152.44	18.7	.0	453.33	210.08
26	218.15	209.64	209.64	16.1	.0	454.31	168.58
27	296.82	288.32	288.32	13.7	.0	455.31	119.76
28	405.01	396.53	396.53	11.7	.0	456.38	62.36
29	553.81	545.34	545.34	10.0	.1	457.62	.00
30	758.69	750.24	750.00	8.7	1.5	459.02	.00

**
 ***** I. Line Characteristics Summary *****
 **

>>> Interpolation level 7 for line type A of 1 type(s)
 Vertical distance to nominal fairlead -14.00 m.
 Vertical separation between endpoints 45.50 m.

- Segment - Type	Length (m.)	Nominal Diameter (mm)	Submerged Weight (kgw/m.)	---- Elastic Coefficients ----		
				Alpha 1 (m.ton**-1)	Alpha 2 (m.ton**-2)	Alpha 3 (m.ton**-3)
1 Chain	457.00	102.00	208.83	0.120E-04	0.000E+00	0.000E+00

Table Index	Top	Anchor	Horizontal	-- Line angle --		Endpoint Separation (m.)	Bottom Length (m.)
	Tension (m.ton)	Tension (m.ton)	Tension (m.ton)	Top (deg)	Anchor (deg)		
1	9.50	.00	.00	90.0	.0	411.50	411.50
2	9.60	.10	.10	89.4	.0	413.54	411.03
3	9.64	.14	.14	89.2	.0	414.10	410.85
4	9.69	.19	.19	88.9	.0	414.80	410.61
5	9.76	.26	.26	88.5	.0	415.65	410.27
6	9.86	.36	.36	87.9	.0	416.69	409.82
7	9.99	.49	.49	87.2	.0	417.93	409.21
8	10.18	.68	.68	86.2	.0	419.40	408.37
9	10.43	.93	.93	84.9	.0	421.10	407.25
10	10.78	1.28	1.28	83.2	.0	423.03	405.75
11	11.26	1.76	1.76	81.0	.0	425.18	403.75
12	11.92	2.42	2.42	78.3	.0	427.51	401.11
13	12.83	3.33	3.33	75.0	.0	429.97	397.68
14	14.08	4.58	4.58	71.0	.0	432.49	393.27
15	15.80	6.30	6.30	66.5	.0	435.02	387.65
16	18.16	8.66	8.66	61.5	.0	437.47	380.60
17	21.41	11.91	11.91	56.2	.0	439.81	371.86
18	25.88	16.38	16.38	50.7	.0	441.99	361.13
19	32.03	22.53	22.53	45.3	.0	443.99	348.09
20	40.48	30.98	30.98	40.1	.0	445.80	332.37
21	52.11	42.61	42.61	35.1	.0	447.43	313.55
22	68.10	58.60	58.60	30.6	.0	448.90	291.12
23	90.08	80.59	80.59	26.5	.0	450.22	264.52
24	120.33	110.84	110.84	22.9	.0	451.42	233.04
25	161.92	152.44	152.44	19.7	.0	452.55	195.90
26	219.12	209.64	209.64	16.9	.0	453.63	152.13
27	297.79	288.32	288.32	14.5	.0	454.73	100.62
28	405.98	396.53	396.53	12.4	.0	455.89	40.04
29	554.82	545.38	545.34	10.6	.7	457.18	.00
30	759.89	750.48	750.00	9.3	2.0	458.59	.00

**
 ***** II. Equilibrium Condition Summary *****
 **

++> User-specified still-water conditions produced the following net mooring force and moment components:

	Global system (Gravity Vertical)	Vessel system (Gravity Vertical)
X Mooring Force	0.00 m.ton	0.00 m.ton
Y Mooring Force	0.00 m.ton	0.00 m.ton
Z Mooring Force	-76.61 m.ton	-76.61 m.ton
Total Plan View Force	0.00 m.ton	0.00 m.ton
Plan View Force Angle	59.04 deg	59.04 deg
X Mooring Moment	.00 ton-meter	.00 ton-meter
Y Mooring Moment	.00 ton-meter	.00 ton-meter
Z Mooring Moment	0.00 ton-meter	0.00 ton-meter

---> These mooring moments are reported about the Vessel coordinate ---
 (Vx,Vy,Vz) = (0.000E-01, 0.000E-01, 0.000E-01)

>>> User-specified still-water line conditions

Line #/Type	Total Tension (m.ton)		Horizontal Tension (m.ton)	Endpoint Separation (m.)	Bottom Length (m.)	Fairlead Line Angle (deg)	
	Top	Anchor				Plan	Profile
1/a	15.60	9.02	9.02	445.51	396.15	-.00	54.75
2/a	15.60	9.02	9.02	445.51	396.15	60.00	54.75
3/a	15.60	9.02	9.02	445.51	396.15	120.00	54.75
4/a	15.60	9.02	9.02	445.51	396.15	180.00	54.75
5/a	15.60	9.02	9.02	445.51	396.15	240.00	54.75
6/a	15.60	9.02	9.02	445.51	396.15	300.00	54.75

***** III. Lateral Offset Restoring Characteristics *****

```

:-----:
::
:: Offset Type: Rectilinear Lateral Translation ::
::
:: Plan-View Offset Direction = 180.00 deg ::
::
:-----:

```

Moments reported about Vessel coordinate
 (Vx,Vy,Vz) = (0.000E-01, 0.000E-01, 0.000E-01)

---- Most Exposed Line Characteristics ----

Offset (m.)	Line #	-- Fairlead Tensions --			Unstretched Suspended Length (m.)	Anchor Forces Rel. to Bottom		Total Restoring Force (m.ton)
		Total (m.ton)	Horiz. (m.ton)	Vert. (m.ton)		<Parallel> (m.ton)	<Perp.> (m.ton)	
.0	1	15.60	9.02	-12.77	60.9	9.02	-.00	-1.431E-06
1.0	1	17.78	11.20	-13.88	66.0	11.20	-.00	-5.778E+00
2.0	1	20.70	14.12	-15.26	72.3	14.12	-.00	-1.196E+01
3.0	1	24.51	17.93	-16.82	79.9	17.93	-.00	-1.888E+01
4.0	1	29.70	23.12	-18.68	89.2	23.12	-.00	-2.729E+01
5.0	1	37.32	30.75	-21.17	101.3	30.75	-.00	-3.788E+01
6.0	1	48.87	42.30	-24.50	117.2	42.30	-.00	-5.285E+01
7.0	1	67.14	60.57	-29.07	138.6	60.57	-.00	-7.480E+01
8.0	1	96.94	90.37	-35.38	167.5	90.37	-.00	-1.084E+02
9.0	1	143.84	137.27	-43.33	205.2	137.27	-.00	-1.601E+02
10.0	1	213.50	206.93	-52.61	251.4	206.93	-.00	-2.348E+02
11.0	1	312.13	305.57	-63.96	304.1	305.57	-.00	-3.403E+02
12.0	1	433.32	426.77	-75.50	358.5	426.77	-.00	-4.690E+02
13.0	1	570.48	563.95	-86.38	412.1	563.95	.26	-6.164E+02
14.0	1	720.62	714.09	-97.30	457.0	714.09	2.93	-7.791E+02

***** III. Lateral Offset Restoring Characteristics *****

```

:-----:
::
:: Offset Type: Rectilinear Lateral Translation ::
::
:: Plan-View Offset Direction = 180.00 deg ::
::
:-----:

```

Moments reported about Vessel coordinate
(Vx,Vy,Vz) = (0.000E-01, 0.000E-01, 0.000E-01)

+++++

Total Restoring Characteristics
and Cross-Coupling Summary

+++++

Offset (m.)	Total Restoring Force (m.ton)	---- Induced Moments ----			---- Vessel-Relative Forces ----			
		Roll	Pitch	Yaw	Orthogonal to Offset	Surge	Sway	Heave
		----- (m.ton*m.) -----			----- (m.ton)-----			
.0	0.0	0.00E-01	0.00E-01	2.11E-05	76.6	0.0	0.0	-76.6
1.0	-5.8	0.00E-01	2.12E+01	3.92E-05	77.3	5.8	0.0	-77.3
2.0	-12.0	-7.63E-06	4.33E+01	3.44E-05	78.1	12.0	0.0	-78.1
3.0	-18.9	0.00E-01	6.61E+01	2.75E-05	79.3	18.9	0.0	-79.3
4.0	-27.3	7.63E-06	9.20E+01	3.56E-05	81.5	27.3	0.0	-81.5
5.0	-37.9	7.63E-06	1.20E+02	4.58E-05	84.2	37.9	0.0	-84.2
6.0	-52.9	0.00E-01	1.56E+02	5.67E-05	88.5	52.9	0.0	-88.5
7.0	-74.8	0.00E-01	2.01E+02	5.25E-05	93.8	74.8	0.0	-93.8
8.0	-108.4	0.00E-01	2.56E+02	6.08E-05	101.5	108.4	0.0	-101.5
9.0	-160.1	0.00E-01	3.27E+02	8.37E-05	111.5	160.1	0.0	-111.5
10.0	-234.8	1.07E-04	4.06E+02	1.04E-04	122.4	234.8	0.0	-122.4
11.0	-340.3	0.00E-01	5.04E+02	1.09E-04	137.0	340.3	0.0	-137.0
12.0	-469.0	7.63E-05	6.01E+02	1.05E-04	151.4	469.0	0.0	-151.4
13.0	-616.4	0.00E-01	6.99E+02	1.36E-04	166.6	616.4	0.0	-166.6
14.0	-779.1	1.22E-03	7.98E+02	3.38E-04	182.2	779.1	0.0	-182.2

***** III. Lateral Offset Restoring Characteristics *****

```

:-----:
::
:: Offset Type: Rectilinear Lateral Translation ::
::
:: Plan-View Offset Direction = 180.00 deg ::
::
:-----:

```

Moments reported about Vessel coordinate
(Vx,Vy,Vz) = (0.000E-01, 0.000E-01, 0.000E-01)

Offset (m.)	<--- Vessel-Relative Forces --->			<--- Vessel-Relative Moments --->		
	Fvx	Fvy	Fvz	Mvx	Mvy	Mvz
	----- (m.ton) -----			----- (m.ton*m.) -----		
.0	0.1431E-05	0.2384E-05	-.7661E+02	0.0000E+00	0.0000E+00	0.2107E-04
1.0	0.5778E+01	0.1907E-05	-.7726E+02	0.0000E+00	0.2120E+02	0.3923E-04
2.0	0.1196E+02	0.1907E-05	-.7807E+02	-.7629E-05	0.4327E+02	0.3439E-04
3.0	0.1888E+02	0.1907E-05	-.7934E+02	0.0000E+00	0.6614E+02	0.2748E-04
4.0	0.2729E+02	0.2861E-05	-.8147E+02	0.7629E-05	0.9200E+02	0.3564E-04
5.0	0.3788E+02	0.1907E-05	-.8419E+02	0.7629E-05	0.1199E+03	0.4578E-04
6.0	0.5285E+02	0.2861E-05	-.8846E+02	0.0000E+00	0.1556E+03	0.5674E-04
7.0	0.7480E+02	0.3815E-05	-.9380E+02	0.0000E+00	0.2009E+03	0.5245E-04
8.0	0.1084E+03	0.3815E-05	-.1015E+03	0.0000E+00	0.2564E+03	0.6080E-04
9.0	0.1601E+03	0.1907E-05	-.1115E+03	0.0000E+00	0.3272E+03	0.8368E-04
10.0	0.2348E+03	-.1144E-04	-.1224E+03	0.1068E-03	0.4056E+03	0.1040E-03
11.0	0.3403E+03	0.7629E-05	-.1370E+03	0.0000E+00	0.5039E+03	0.1092E-03
12.0	0.4690E+03	-.3815E-05	-.1514E+03	0.7629E-04	0.6011E+03	0.1049E-03
13.0	0.6164E+03	0.1144E-04	-.1666E+03	0.0000E+00	0.6989E+03	0.1364E-03
14.0	0.7791E+03	-.6752E-03	-.1822E+03	0.1221E-02	0.7984E+03	0.3376E-03

***** III. Lateral Offset Restoring Characteristics *****

```

:
:
: Offset Type: Rectilinear Lateral Translation :
:
:
: Plan-View Offset Direction = 180.00 deg :
:
:

```

Moments reported about Vessel coordinate
(Vx,Vy,Vz) = (0.000E-01, 0.000E-01, 0.000E-01)

>>> Raw Mooring Stiffness matrix in vessel-bound system (Vx, Vy, Vz)

dFx/dx	dFy/dx	dFz/dx	dMx/dx	dMy/dx	dMz/dx
dFx/dy	dFy/dy	dFz/dy	dMx/dy	dMy/dy	dMz/dy
dFx/dz	dFy/dz	dFz/dz	dMx/dz	dMy/dz	dMz/dz
dFx/dPx	dFy/dPx	dFz/dPx	dMx/dPx	dMy/dPx	dMz/dPx
dFx/dPy	dFy/dPy	dFz/dPy	dMx/dPy	dMy/dPy	dMz/dPy
dFx/dPz	dFy/dPz	dFz/dPz	dMx/dPz	dMy/dPz	dMz/dPz

Column => 1 2 3 4 5 6

Row	Offset Value = .00 m.					
v						
1	-.6602E+01	-.7153E-05	0.0000E+00	0.0000E+00	-.2896E+02	0.8158E-05
2	-.2384E-05	-.6602E+01	0.0000E+00	0.2893E+02	-.3815E-04	-.1276E-03
3	-.4768E-05	0.0000E+00	-.5734E+01	0.0000E+00	-.3815E-04	0.1838E-04
4	0.0000E+00	-.5249E+02	-.2186E-02	-.3398E+03	0.0000E+00	-.5421E-03
5	0.5241E+02	0.0000E+00	0.0000E+00	0.0000E+00	-.3404E+03	0.0000E+00
6	-.4098E-03	-.6830E-03	0.0000E+00	0.0000E+00	-.2186E-02	-.3933E+03

Column => 1 2 3 4 5 6

Row	Offset Value = 1.00 m.					
v						
1	-.5545E+01	-.4768E-05	0.5076E+00	0.7629E-04	-.1847E+02	0.4686E-04
2	-.1192E-04	-.5541E+01	0.0000E+00	0.1893E+02	-.1907E-04	-.1038E-01
3	0.5215E+00	-.4768E-05	-.4239E+01	-.3815E-04	0.1377E+01	0.9015E-05
4	0.4098E-03	-.5719E+02	0.0000E+00	-.3049E+03	-.5464E-02	-.2150E+02
5	0.5723E+02	-.5464E-03	0.7165E+01	-.2186E-02	-.3066E+03	0.2178E-02
6	0.8196E-03	-.5793E+01	0.0000E+00	-.2535E+00	0.3278E-02	-.4011E+03

Column => 1 2 3 4 5 6

Row	Offset Value = 2.00 m.					
v						
1	-.6188E+01	0.4768E-05	0.1012E+01	0.3815E-04	-.1969E+02	-.2906E-04
2	0.0000E+00	-.5542E+01	0.0000E+00	0.1818E+02	-.5722E-04	-.2069E-01
3	0.1062E+01	-.4768E-05	-.4222E+01	0.0000E+00	0.2644E+01	0.8941E-05
4	0.0000E+00	-.5814E+02	0.0000E+00	-.3067E+03	0.2186E-02	-.4389E+02
5	0.5686E+02	0.0000E+00	0.1460E+02	0.0000E+00	-.3204E+03	0.2169E-02
6	0.0000E+00	-.1196E+02	0.0000E+00	-.6601E+00	0.4371E-02	-.4176E+03

Column => 1 2 3 4 5 6

Row	Offset Value = 3.00 m.					
v						
1	-.8456E+01	0.0000E+00	0.2290E+01	-.3815E-04	-.3067E+02	-.5811E-04
2	0.0000E+00	-.7181E+01	0.3815E-04	0.2949E+02	0.0000E+00	0.2609E-01
3	0.2004E+01	-.4768E-05	-.5651E+01	-.7629E-04	0.5494E+01	-.5752E-04
4	0.0000E+00	-.5422E+02	0.0000E+00	-.3513E+03	0.0000E+00	-.6730E+02
5	0.5231E+02	0.2732E-03	0.2436E+02	-.2186E-02	-.3769E+03	-.8538E-05
6	0.5464E-03	-.1887E+02	0.0000E+00	-.1311E+01	0.4371E-02	-.4462E+03

Column => 1 2 3 4 5 6

Row	Offset Value = 4.00 m.					
v						
1	-.1029E+02	-.9537E-05	0.3544E+01	-.3815E-04	-.3135E+02	-.2861E-04
2	-.9537E-05	-.6493E+01	0.0000E+00	0.2025E+02	-.3815E-04	-.4208E-01
3	0.3069E+01	-.4768E-05	-.4844E+01	-.7629E-04	0.9630E+01	0.0000E+00
4	0.0000E+00	-.5972E+02	0.0000E+00	-.3263E+03	0.0000E+00	-.9335E+02
5	0.5152E+02	0.2732E-03	0.3692E+02	0.0000E+00	-.4063E+03	0.0000E+00
6	0.0000E+00	-.2732E+02	0.0000E+00	-.1285E+01	-.4371E-02	-.4926E+03

Column => 1 2 3 4 5 6

Row	Offset Value = 5.00 m.					
v						
1	-.1200E+02	-.4768E-05	0.2632E+01	-.7629E-04	-.2971E+02	0.5662E-04
2	-.1907E-04	-.6502E+01	-.3815E-04	0.1792E+02	-.7629E-04	-.1070E+00
3	0.2665E+01	0.0000E+00	-.4273E+01	0.0000E+00	0.3177E+01	0.9537E-05
4	0.0000E+00	-.6300E+02	0.2186E-02	-.3319E+03	0.2186E-02	-.1215E+03
5	0.5659E+02	0.2732E-03	0.4095E+02	-.2186E-02	-.4367E+03	-.2732E-02
6	0.0000E+00	-.3801E+02	0.0000E+00	-.1329E+01	-.4371E-02	-.5597E+03

Column => 1 2 3 4 5 6

Row	Offset Value = 6.00 m.					
v						
1	-.1759E+02	0.6580E-03	0.4789E+01	-.1984E-02	-.3894E+02	-.5960E-06
2	-.1907E-04	-.9044E+01	0.3815E-04	0.3064E+02	0.0000E+00	-.1371E-01
3	0.4162E+01	0.4768E-05	-.5231E+01	-.7629E-04	0.7633E+01	-.2861E-04
4	0.0000E+00	-.6069E+02	-.2186E-02	-.3883E+03	0.0000E+00	-.1582E+03
5	0.5388E+02	-.5464E-03	0.6040E+02	0.0000E+00	-.5330E+03	0.0000E+00
6	0.1093E-02	-.5286E+02	0.0000E+00	-.2865E+01	0.4371E-02	-.6650E+03

Column => 1 2 3 4 5 6

Row	Offset Value = 7.00 m.					
v						
1	-.2906E+02	0.0000E+00	0.7398E+01	0.0000E+00	-.5749E+02	-.1907E-04
2	-.7629E-03	-.8854E+01	0.5341E-03	0.2412E+02	-.1602E-02	-.2434E+00
3	0.7093E+01	0.9537E-05	-.5679E+01	-.3815E-04	0.1432E+02	0.1907E-04
4	0.4371E-02	-.6753E+02	0.0000E+00	-.3941E+03	-.4371E-02	-.2038E+03
5	0.3933E+02	0.0000E+00	0.8858E+02	-.2186E-02	-.7133E+03	0.0000E+00
6	0.2186E-02	-.7497E+02	0.0000E+00	-.3080E+01	0.0000E+00	-.8238E+03

```
-----
Column => 1          2          3          4          5          6
-----
Row
|
v
      Offset Value =      8.00 m.

1  -.4397E+02  0.9537E-05  0.1046E+02  -.3815E-04  -.7210E+02  0.4292E-04
2  0.0000E+00  -.1256E+02  0.0000E+00  0.3797E+02  0.0000E+00  -.1898E+00
3  0.9349E+01  0.0000E+00  -.6436E+01  0.3815E-04  0.1824E+02  -.3815E-04
4  0.0000E+00  -.6794E+02  0.0000E+00  -.4448E+03  0.0000E+00  -.2606E+03
5  0.3503E+02  -.5464E-03  0.1267E+03  -.4371E-02  -.9420E+03  -.2459E-02
6  0.0000E+00  -.1086E+03  -.2186E-02  -.4673E+01  0.8743E-02  -.1074E+04
-----
```

```
-----
Column => 1          2          3          4          5          6
-----
Row
|
v
      Offset Value =      9.00 m.

1  -.6020E+02  0.0000E+00  0.9679E+01  0.0000E+00  -.6841E+02  0.4768E-05
2  0.7629E-04  -.1265E+02  0.0000E+00  0.3066E+02  0.0000E+00  -.8067E+00
3  0.1040E+02  0.9537E-05  -.5706E+01  0.7629E-04  0.1517E+02  0.4768E-05
4  -.4371E-02  -.7959E+02  0.0000E+00  -.4641E+03  0.8743E-02  -.3317E+03
5  0.3814E+02  0.5464E-03  0.1753E+03  0.0000E+00  -.1269E+04  0.1708E-02
6  0.0000E+00  -.1609E+03  -.4371E-02  -.4380E+01  -.1749E-01  -.1464E+04
-----
```

```
-----
Column => 1          2          3          4          5          6
-----
Row
|
v
      Offset Value =     10.00 m.

1  -.8882E+02  0.1516E-02  0.1319E+02  -.3891E-02  -.8863E+02  -.2337E-03
2  -.7629E-04  -.1756E+02  -.3815E-04  0.4663E+02  0.0000E+00  -.1044E+01
3  0.1232E+02  0.0000E+00  -.6872E+01  0.1526E-03  0.1676E+02  -.4768E-04
4  0.4371E-02  -.7883E+02  0.0000E+00  -.5527E+03  0.0000E+00  -.4124E+03
5  0.3882E+02  0.0000E+00  0.2516E+03  -.4371E-02  -.1791E+04  -.2186E-02
6  0.0000E+00  -.2355E+03  0.0000E+00  -.8528E+01  0.0000E+00  -.2024E+04
-----
```

```
-----
Column => 1          2          3          4          5          6
-----
Row
|
v
      Offset Value =     11.00 m.

1  -.1240E+03  -.9537E-05  0.1673E+02  0.7629E-04  -.1135E+03  0.4530E-04
2  -.1526E-03  -.1860E+02  0.7629E-04  0.3689E+02  -.4578E-03  -.2281E+01
3  0.1497E+02  -.9537E-05  -.6322E+01  0.7629E-04  0.2118E+02  0.3815E-04
4  -.8743E-02  -.9763E+02  0.0000E+00  -.5670E+03  0.0000E+00  -.5106E+03
5  0.3502E+02  0.0000E+00  0.3616E+03  0.0000E+00  -.2534E+04  0.2186E-02
6  0.0000E+00  -.3426E+03  0.0000E+00  -.6443E+01  0.0000E+00  -.2821E+04
-----
```

```
-----
Column => 1          2          3          4          5          6
-----
Row
|
v
      Offset Value =     12.00 m.

1  -.1455E+03  -.2308E-02  0.1865E+02  0.5417E-02  -.1183E+03  0.2789E-03
2  0.1526E-03  -.2774E+02  0.7629E-04  0.6223E+02  0.3052E-03  -.2343E+01
3  0.1614E+02  0.1907E-04  -.7418E+01  0.0000E+00  0.2471E+02  0.0000E+00
4  0.0000E+00  -.9784E+02  -.4371E-02  -.6809E+03  0.0000E+00  -.6111E+03
5  0.4741E+02  0.0000E+00  0.4938E+03  0.0000E+00  -.3432E+04  -.5464E-03
6  0.0000E+00  -.4714E+03  0.0000E+00  -.1154E+02  -.1749E-01  -.3793E+04
-----
```

```
-----
Column => 1          2          3          4          5          6
-----
Row
|
v
      Offset Value =     13.00 m.

1  -.1604E+03  0.2327E-02  0.1688E+02  -.3510E-02  -.1135E+03  -.4864E-03
2  0.0000E+00  -.2799E+02  -.7629E-04  0.4548E+02  0.0000E+00  -.4212E+01
3  0.1534E+02  0.0000E+00  -.6667E+01  0.0000E+00  0.2059E+02  -.1526E-03
4  0.0000E+00  -.1172E+03  -.4371E-02  -.7426E+03  0.0000E+00  -.7089E+03
5  0.6629E+02  -.1093E-02  0.6371E+03  0.0000E+00  -.4440E+04  -.4371E-02
6  0.1749E-01  -.6206E+03  0.0000E+00  -.9390E+01  0.1749E-01  -.4918E+04
-----
```

```
-----
Column => 1          2          3          4          5          6
-----
Row
|
v
      Offset Value =     14.00 m.

1  -.1654E+03  -.1907E-04  0.1454E+02  0.7629E-04  -.8710E+02  -.4768E-05
2  0.0000E+00  -.4122E+02  0.7629E-04  0.7341E+02  0.3052E-03  -.3481E+01
3  0.1611E+02  0.1907E-04  -.7584E+01  -.2289E-03  0.2268E+02  0.0000E+00
4  0.0000E+00  -.1159E+03  0.0000E+00  -.9046E+03  0.0000E+00  -.8129E+03
5  0.8381E+02  0.0000E+00  0.8017E+03  -.4371E-02  -.5556E+04  0.0000E+00
6  -.1749E-01  -.7823E+03  0.0000E+00  -.1658E+02  -.1749E-01  -.6170E+04
-----
```

***** Total Fairlead Line Tensions *****
(m.ton)

::: Offsets :::
::
:: Offset Type: Rectilinear Lateral Translation ::
::
:: Plan-View Offset Direction = 180.00 deg ::
::
::: Offsets :::

Table with 7 columns: Line #, 1, 2, 3, 4, 5, 6. Rows show Offset (m.) values for lines 1 through 14.

***** IV. Yaw Offset Restoring Characteristics *****

::: Offsets :::
::
:: Offset Type: Rotational Yaw Translation ::
::
:: Rotation Sense = 1. (C-Clockwise) ::
::
::: Offsets :::

Moments reported about Vessel coordinate
(Vx,Vy,Vz) = (0.000E-01, 0.000E-01, 0.000E-01)

---- Most Exposed Line Characteristics ----

Table with 9 columns: Offset (deg), Line #, Fairlead Tensions (Total, Horiz., Vert.), Unstretched Suspended Length (m.), Anchor Forces (Rel. to Bottom, <Parallel>, <Perp.>), Total Yaw Restoring Moment (m.ton*m.). Rows show characteristics for lines 1 through 35.

***** IV. Yaw Offset Restoring Characteristics *****

```

:-----:
:
: Offset Type: Rotational Yaw Translation :
:
: Rotation Sense = 1. (C-Clockwise) :
:
:-----:
    
```

Moments reported about Vessel coordinate
(Vx,Vy,Vz) = (0.000E-01, 0.000E-01, 0.000E-01)

+++++
Total Restoring Characteristics
and Cross-Coupling Summary
+++++

Offset (deg)	Total Yaw Restoring Moment (m.ton*m.)	---- Induced Moments ----			Vessel-Relative Forces		
		Roll	Pitch	Yaw	Surge	Sway	Heave
		----- (m.ton*m.)	----- (m.ton*m.)	-----	----- (m.ton)	-----	-----
.0	2.107E-05	0.00E-01	0.00E-01	2.11E-05	0.0	0.0	-76.6
2.5	-1.718E+01	0.00E-01	-7.63E-06	-1.72E+01	0.0	.0	-76.7
5.0	-3.451E+01	7.63E-06	-1.14E-05	-3.45E+01	0.0	0.0	-76.8
7.5	-5.210E+01	-7.63E-06	0.00E-01	-5.21E+01	0.0	0.0	-77.1
10.0	-7.010E+01	0.00E-01	0.00E-01	-7.01E+01	.0	0.0	-77.5
12.5	-8.864E+01	7.63E-06	-7.63E-06	-8.86E+01	0.0	0.0	-78.0
15.0	-1.078E+02	0.00E-01	3.81E-06	-1.08E+02	0.0	0.0	-78.5
17.5	-1.278E+02	0.00E-01	0.00E-01	-1.28E+02	0.0	0.0	-79.2
20.0	-1.486E+02	7.63E-06	0.00E-01	-1.49E+02	0.0	.0	-79.9
22.5	-1.704E+02	0.00E-01	3.81E-06	-1.70E+02	0.0	0.0	-80.6
25.0	-1.932E+02	-7.63E-06	-3.81E-06	-1.93E+02	0.0	0.0	-81.4
27.5	-2.172E+02	7.63E-06	3.81E-06	-2.17E+02	0.0	0.0	-82.3
30.0	-2.423E+02	0.00E-01	-3.81E-06	-2.42E+02	0.0	0.0	-83.1
32.5	-2.687E+02	0.00E-01	-7.63E-06	-2.69E+02	0.0	0.0	-83.9
35.0	-2.962E+02	0.00E-01	7.63E-06	-2.96E+02	0.0	0.0	-84.8

***** IV. Yaw Offset Restoring Characteristics *****

```

:-----:
:
: Offset Type: Rotational Yaw Translation :
:
: Rotation Sense = 1. (C-Clockwise) :
:
:-----:
    
```

Moments reported about Vessel coordinate
(Vx,Vy,Vz) = (0.000E-01, 0.000E-01, 0.000E-01)

Offset (deg)	<--- Vessel-Relative Forces --->			<--- Vessel-Relative Moments --->		
	Fvx	Fvy	Fvz	Mvx	Mvy	Mvz
	----- (m.ton)	----- (m.ton)	-----	----- (m.ton*m.)	----- (m.ton*m.)	-----
.0	0.1431E-05	0.2384E-05	-.7661E+02	0.0000E+00	0.0000E+00	0.2107E-04
2.5	0.1431E-05	0.0000E+00	-.7667E+02	0.0000E+00	-.7629E-05	-.1718E+02
5.0	0.1192E-05	-.2861E-05	-.7684E+02	0.7629E-05	-.1144E-04	-.3451E+02
7.5	0.9537E-06	-.9537E-06	-.7711E+02	-.7629E-05	0.0000E+00	-.5210E+02
10.0	0.0000E+00	-.1907E-05	-.7749E+02	0.0000E+00	0.0000E+00	-.7010E+02
12.5	0.2384E-05	0.9537E-06	-.7796E+02	0.7629E-05	-.7629E-05	-.8864E+02
15.0	0.4768E-06	-.3815E-05	-.7852E+02	0.0000E+00	0.3815E-05	-.1078E+03
17.5	-.9537E-06	-.2861E-05	-.7916E+02	0.0000E+00	0.0000E+00	-.1278E+03
20.0	0.2146E-05	0.0000E+00	-.7987E+02	0.7629E-05	0.0000E+00	-.1486E+03
22.5	0.1907E-05	-.1907E-05	-.8063E+02	0.0000E+00	0.3815E-05	-.1704E+03
25.0	0.4768E-06	-.2861E-05	-.8143E+02	-.7629E-05	-.3815E-05	-.1932E+03
27.5	-.9537E-06	-.1907E-05	-.8226E+02	0.7629E-05	0.3815E-05	-.2172E+03
30.0	0.2384E-05	-.9537E-06	-.8310E+02	0.0000E+00	-.3815E-05	-.2423E+03
32.5	-.9537E-06	-.9537E-06	-.8395E+02	0.0000E+00	-.7629E-05	-.2687E+03
35.0	0.2861E-05	-.1907E-05	-.8478E+02	0.0000E+00	0.7629E-05	-.2962E+03

***** IV. Yaw Offset Restoring Characteristics *****

```

:-----:
:      :
:      :
: Offset Type: Rotational Yaw Translation :
:      :
:      :
:      :
: Rotation Sense = 1. (C-Clockwise)     :
:      :
:-----:

```

Moments reported about Vessel coordinate
(Vx,Vy,Vz) = (0.000E-01, 0.000E-01, 0.000E-01)

>>> Raw Mooring Stiffness matrix in vessel-bound system (Vx, Vy, Vz)

dFx/dx	dFy/dx	dFz/dx	dMx/dx	dMy/dx	dMz/dx
dFx/dy	dFy/dy	dFz/dy	dMx/dy	dMy/dy	dMz/dy
dFx/dz	dFy/dz	dFz/dz	dMx/dz	dMy/dz	dMz/dz
dFx/dPx	dFy/dPx	dFz/dPx	dMx/dPx	dMy/dPx	dMz/dPx
dFx/dPy	dFy/dPy	dFz/dPy	dMx/dPy	dMy/dPy	dMz/dPy
dFx/dPz	dFy/dPz	dFz/dPz	dMx/dPz	dMy/dPz	dMz/dPz

Column => 1 2 3 4 5 6

Row	Offset Value = .00 deg					
v						
1	-.6602E+01	-.7153E-05	0.0000E+00	0.0000E+00	-.2896E+02	0.8158E-05
2	-.2384E-05	-.6602E+01	0.0000E+00	0.2893E+02	-.3815E-04	-.1276E-03
3	-.4768E-05	0.0000E+00	-.5734E+01	0.0000E+00	-.3815E-04	0.1838E-04
4	0.0000E+00	-.5249E+02	-.2186E-02	-.3398E+03	0.0000E+00	-.5421E-03
5	0.5241E+02	0.0000E+00	0.0000E+00	0.0000E+00	-.3404E+03	0.0000E+00
6	-.4098E-03	-.6830E-03	0.0000E+00	0.0000E+00	-.2186E-02	-.3933E+03

Column => 1 2 3 4 5 6

Row	Offset Value = 2.50 deg					
v						
1	-.6601E+01	0.1907E-04	0.0000E+00	0.1280E+01	-.2885E+02	-.6676E-04
2	-.1001E-03	-.6601E+01	0.0000E+00	0.2882E+02	0.1278E+01	-.9537E-04
3	-.2384E-05	-.2384E-05	-.5721E+01	-.7629E-04	0.0000E+00	-.2142E+01
4	0.1069E+01	-.5258E+02	0.2186E-02	-.3396E+03	-.8593E+01	-.5464E-03
5	0.5250E+02	0.1072E+01	0.0000E+00	0.8583E+01	-.3402E+03	-.1093E-02
6	-.1366E-03	0.5464E-03	-.2540E+01	-.2186E-02	0.0000E+00	-.3949E+03

Column => 1 2 3 4 5 6

Row	Offset Value = 5.00 deg					
v						
1	-.6601E+01	0.3815E-04	0.0000E+00	0.2537E+01	-.2853E+02	0.0000E+00
2	-.2849E-03	-.6601E+01	0.0000E+00	0.2851E+02	0.2532E+01	0.0000E+00
3	0.5960E-05	-.9537E-05	-.5683E+01	0.0000E+00	-.1907E-04	-.4274E+01
4	0.2133E+01	-.5285E+02	0.2186E-02	-.3390E+03	-.1727E+02	-.1093E-02
5	0.5278E+02	0.2138E+01	-.2186E-02	0.1724E+02	-.3396E+03	0.1093E-02
6	0.1366E-03	0.2732E-03	-.5066E+01	-.2186E-02	0.0000E+00	-.3996E+03

Column => 1 2 3 4 5 6

Row	Offset Value = 7.50 deg					
v						
1	-.6602E+01	0.1144E-03	0.3815E-04	0.3748E+01	-.2801E+02	0.3815E-04
2	-.4506E-03	-.6603E+01	0.0000E+00	0.2799E+02	0.3742E+01	-.5722E-04
3	0.9537E-05	-.9537E-05	-.5620E+01	0.0000E+00	0.3815E-04	-.6383E+01
4	0.3185E+01	-.5331E+02	-.2186E-02	-.3380E+03	-.2606E+02	0.0000E+00
5	0.5323E+02	0.3194E+01	0.0000E+00	0.2602E+02	-.3387E+03	-.1093E-02
6	0.8879E-03	-.8196E-03	-.7530E+01	0.0000E+00	0.1093E-02	-.4075E+03

Column => 1 2 3 4 5 6

Row	Offset Value = 10.00 deg					
v						
1	-.6603E+01	0.1001E-03	0.3815E-04	0.4893E+01	-.2730E+02	-.7629E-04
2	0.3242E-03	-.6603E+01	0.0000E+00	0.2727E+02	0.4887E+01	0.1526E-03
3	-.1073E-04	0.4768E-05	-.5533E+01	0.0000E+00	-.5722E-04	-.8459E+01
4	0.4222E+01	-.5393E+02	0.0000E+00	-.3367E+03	-.3507E+02	-.2186E-02
5	0.5386E+02	0.4232E+01	0.0000E+00	0.3504E+02	-.3373E+03	0.0000E+00
6	0.2732E-03	0.0000E+00	-.9781E+01	-.2186E-02	-.1093E-02	-.4182E+03

Column => 1 2 3 4 5 6

Row	Offset Value = 12.50 deg					
v						
1	-.6604E+01	-.2527E-03	0.3815E-04	0.5952E+01	-.2640E+02	-.1526E-03
2	0.5794E-03	-.6604E+01	0.0000E+00	0.2637E+02	0.5944E+01	0.0000E+00
3	0.5960E-05	-.9537E-05	-.5424E+01	-.3815E-04	0.7629E-04	-.1049E+02
4	0.5237E+01	-.5473E+02	0.0000E+00	-.3350E+03	-.4433E+02	-.2186E-02
5	0.5466E+02	0.5250E+01	-.2186E-02	0.4430E+02	-.3356E+03	0.0000E+00
6	-.2732E-03	-.1639E-02	-.1188E+02	0.4371E-02	-.1093E-02	-.4318E+03

Column => 1 2 3 4 5 6

Row	Offset Value = 15.00 deg					
v						
1	-.6605E+01	0.1431E-03	0.3815E-04	0.6901E+01	-.2533E+02	0.1144E-03
2	0.1991E-03	-.6605E+01	0.0000E+00	0.2531E+02	0.6892E+01	0.0000E+00
3	-.5960E-05	-.4768E-05	-.5294E+01	0.3815E-04	0.0000E+00	-.1247E+02
4	0.6225E+01	-.5568E+02	0.0000E+00	-.3330E+03	-.5393E+02	0.0000E+00
5	0.5561E+02	0.6240E+01	0.0000E+00	0.5390E+02	-.3335E+03	0.4371E-02
6	0.9562E-03	0.5464E-03	-.1380E+02	0.2186E-02	0.1093E-02	-.4482E+03

Column => 1 2 3 4 5 6

Row	Offset Value = 17.50 deg					
v						
1	-.6606E+01	0.3529E-03	0.3815E-04	0.7733E+01	-.2412E+02	0.0000E+00
2	0.8476E-03	-.6606E+01	0.0000E+00	0.2409E+02	0.7725E+01	-.3815E-04
3	0.1192E-05	0.4768E-05	-.5144E+01	-.3815E-04	-.1907E-04	-.1438E+02
4	0.7181E+01	-.5677E+02	0.0000E+00	-.3305E+03	-.6392E+02	-.2186E-02
5	0.5670E+02	0.7200E+01	0.0000E+00	0.6387E+02	-.3311E+03	0.0000E+00
6	-.4098E-03	-.2732E-03	-.1547E+02	0.0000E+00	-.1093E-02	-.4671E+03

```

-----
Column => 1          2          3          4          5          6
-----
Row
|
v
          Offset Value = 20.00 deg
1  -.6608E+01  -.3815E-04  0.3815E-04  0.8432E+01  -.2277E+02  -.7629E-04
2  -.1597E-03  -.6607E+01  -.3815E-04  0.2274E+02  0.8418E+01  0.7629E-04
3  -.5960E-05  -.1907E-04  -.4978E+01  0.0000E+00  -.1907E-04  -.1622E+02
4  0.8102E+01  -.5799E+02  0.2186E-02  -.3278E+03  -.7433E+02  0.0000E+00
5  0.5792E+02  0.8121E+01  0.0000E+00  0.7427E+02  -.3283E+03  -.8743E-02
6  -.3415E-03  -.2732E-03  -.1685E+02  0.0000E+00  0.0000E+00  -.4881E+03
-----

```

```

-----
Column => 1          2          3          4          5          6
-----
Row
|
v
          Offset Value = 22.50 deg
1  -.6609E+01  0.1144E-03  -.3815E-04  0.8985E+01  -.2132E+02  0.0000E+00
2  -.2193E-03  -.6610E+01  -.3815E-04  0.2129E+02  0.8970E+01  0.7629E-04
3  0.0000E+00  0.1431E-04  -.4797E+01  -.7629E-04  0.1907E-04  -.1798E+02
4  0.8981E+01  -.5932E+02  0.0000E+00  -.3246E+03  -.8524E+02  0.0000E+00
5  0.5926E+02  0.9002E+01  0.0000E+00  0.8517E+02  -.3251E+03  -.4371E-02
6  -.6830E-04  -.2732E-03  -.1796E+02  0.0000E+00  -.3278E-02  -.5112E+03
-----

```

```

-----
Column => 1          2          3          4          5          6
-----
Row
|
v
          Offset Value = 25.00 deg
1  -.6611E+01  0.0000E+00  0.0000E+00  0.9387E+01  -.1978E+02  -.1526E-03
2  -.1717E-03  -.6611E+01  0.0000E+00  0.1975E+02  0.9371E+01  0.0000E+00
3  -.2384E-05  -.4768E-05  -.4603E+01  -.3815E-04  -.5722E-04  -.1965E+02
4  0.9816E+01  -.6075E+02  0.0000E+00  -.3211E+03  -.9667E+02  0.0000E+00
5  0.6069E+02  0.9840E+01  -.2186E-02  0.9657E+02  -.3215E+03  0.0000E+00
6  0.3586E-03  0.2732E-03  -.1874E+02  0.2186E-02  0.3278E-02  -.5359E+03
-----

```

```

-----
Column => 1          2          3          4          5          6
-----
Row
|
v
          Offset Value = 27.50 deg
1  -.6614E+01  -.4768E-03  0.0000E+00  0.9633E+01  -.1817E+02  0.7629E-04
2  -.4601E-03  -.6613E+01  0.0000E+00  0.1814E+02  0.9614E+01  -.7629E-04
3  -.1192E-04  0.9537E-05  -.4399E+01  0.0000E+00  0.1907E-04  -.2122E+02
4  0.1060E+02  -.6226E+02  -.2186E-02  -.3172E+03  -.1086E+03  0.4371E-02
5  0.6221E+02  0.1062E+02  0.0000E+00  0.1086E+03  -.3176E+03  0.4371E-02
6  -.4013E-03  0.2732E-03  -.1924E+02  0.0000E+00  0.1093E-02  -.5623E+03
-----

```

```

-----
Column => 1          2          3          4          5          6
-----
Row
|
v
          Offset Value = 30.00 deg
1  -.6615E+01  0.1574E-03  0.0000E+00  0.9716E+01  -.1652E+02  -.7629E-04
2  -.5198E-03  -.6616E+01  -.3815E-04  0.1650E+02  0.9699E+01  0.1526E-03
3  -.7153E-05  0.0000E+00  -.4187E+01  0.0000E+00  0.1907E-04  -.2268E+02
4  0.1134E+02  -.6383E+02  -.2186E-02  -.3130E+03  -.1212E+03  0.4371E-02
5  0.6378E+02  0.1136E+02  -.2186E-02  0.1211E+03  -.3133E+03  -.4371E-02
6  -.1494E-04  0.8196E-03  -.1942E+02  0.2186E-02  0.3278E-02  -.5897E+03
-----

```

```

-----
Column => 1          2          3          4          5          6
-----
Row
|
v
          Offset Value = 32.50 deg
1  -.6619E+01  -.1240E-03  0.3815E-04  0.9643E+01  -.1485E+02  0.0000E+00
2  0.1454E-03  -.6618E+01  0.0000E+00  0.1482E+02  0.9626E+01  0.0000E+00
3  -.7153E-05  -.9537E-05  -.3969E+01  0.7629E-04  0.7629E-04  -.2403E+02
4  0.1202E+02  -.6544E+02  0.0000E+00  -.3083E+03  -.1344E+03  0.0000E+00
5  0.6540E+02  0.1204E+02  0.0000E+00  0.1343E+03  -.3087E+03  0.0000E+00
6  0.1042E-02  0.0000E+00  -.1928E+02  0.0000E+00  0.3278E-02  -.6178E+03
-----

```

```

-----
Column => 1          2          3          4          5          6
-----
Row
|
v
          Offset Value = 35.00 deg
1  -.7989E+01  0.9227E-01  0.0000E+00  0.1475E+02  -.2186E+02  0.0000E+00
2  0.5261E-01  -.8012E+01  0.0000E+00  0.2134E+02  0.1572E+02  0.0000E+00
3  0.4768E-05  0.4768E-05  -.4958E+01  0.0000E+00  0.5722E-04  -.3006E+02
4  0.1264E+02  -.6709E+02  0.0000E+00  -.3033E+03  -.1482E+03  0.0000E+00
5  0.6704E+02  0.1266E+02  0.0000E+00  0.1481E+03  -.3036E+03  0.8743E-02
6  -.2152E-02  0.5464E-03  -.1880E+02  0.2186E-02  -.1093E-02  -.6462E+03
-----

```

***** Total Fairlead Line Tensions *****
(m.ton)

```

:
:
: Offset Type: Rotational Yaw Translation :
:
: Rotation Sense = 1. (C-Clockwise) :
:
:

```

Line #:	1	2	3	4	5	6
Offset (deg)						
.00	15.60	15.60	15.60	15.60	15.60	15.60
2.50	15.62	15.61	15.62	15.62	15.61	15.62
5.00	15.66	15.66	15.66	15.66	15.66	15.66
7.50	15.74	15.73	15.74	15.74	15.73	15.74
10.00	15.84	15.84	15.84	15.84	15.84	15.84
12.50	15.98	15.97	15.98	15.98	15.97	15.98
15.00	16.14	16.14	16.14	16.14	16.14	16.14
17.50	16.33	16.33	16.34	16.33	16.33	16.34
20.00	16.55	16.55	16.56	16.55	16.55	16.56
22.50	16.80	16.80	16.81	16.80	16.80	16.81
25.00	17.08	17.08	17.09	17.08	17.08	17.09
27.50	17.39	17.38	17.39	17.39	17.38	17.39
30.00	17.72	17.71	17.73	17.72	17.71	17.73
32.50	18.08	18.07	18.08	18.08	18.07	18.08
35.00	18.46	18.45	18.47	18.46	18.45	18.47

***** V. Oblique Axis Rotational Offset Characteristics *****

```

:
:
: Offset Type: Oblique Axis Rotation :
:
: Axis Direction (Gx,Gy,Gz) = ( 1.00, 1.00, 1.00) :
: Rotation Sense = 1. (Advancing right-handed screw) :
:
:

```

Moments reported about Vessel coordinate
(Vx,Vy,Vz) = (0.000E-01, 0.000E-01, 0.000E-01)

---- Most Exposed Line Characteristics ----

Offset (deg)	Line #	-- Fairlead Tensions --			Unstretched Suspended Length (m.)	Anchor Forces Rel. to Bottom		Total Restoring Moment (m.ton*m.)
		Total (m.ton)	Horiz. (m.ton)	Vert. (m.ton)		<Parallel> (m.ton)	<Perp.> (m.ton)	
.0	1	15.60	9.02	-12.77	60.9	9.02	-.00	7.543E-06
2.5	3	15.69	9.06	-12.85	61.3	9.06	-.00	-1.269E+01
5.0	3	15.82	9.14	-12.96	61.8	9.14	-.00	-2.547E+01
7.5	3	15.99	9.25	-13.09	62.4	9.25	-.00	-3.841E+01
10.0	3	16.19	9.40	-13.24	63.0	9.40	-.00	-5.158E+01
12.5	3	16.42	9.57	-13.41	63.8	9.57	-.00	-6.506E+01
15.0	3	16.68	9.78	-13.60	64.6	9.78	-.00	-7.891E+01
17.5	3	16.98	10.02	-13.79	65.5	10.02	-.00	-9.320E+01
20.0	3	17.30	10.28	-14.00	66.5	10.28	-.00	-1.080E+02
22.5	3	17.65	10.57	-14.21	67.5	10.57	-.00	-1.233E+02
25.0	3	18.02	10.88	-14.43	68.7	10.88	-.00	-1.392E+02
27.5	3	18.42	11.22	-14.65	69.8	11.22	-.00	-1.558E+02
30.0	3	18.84	11.58	-14.88	71.1	11.58	-.00	-1.730E+02
32.5	3	19.30	11.99	-15.12	72.4	11.99	-.00	-1.911E+02
35.0	3	19.96	12.59	-15.55	74.1	12.59	-.00	-2.115E+02

***** V. Oblique Axis Rotational Offset Characteristics *****

```

:-----:
::
::          Offset Type: Oblique Axis Rotation      ::
::          ::
::          Axis Direction (Gx,Gy,Gz) = ( 1.00, 1.00, 1.00)  ::
::          Rotation Sense = 1. (Advancing right-handed screw)  ::
::          ::
:-----:

```

Moments reported about Vessel coordinate
(Vx,Vy,Vz) = (0.000E-01, 0.000E-01, 0.000E-01)

Total Restoring Characteristics
and Cross-Coupling Summary

Offset (deg)	Total Restoring Moment (m.ton*m.)	---- Induced Moments ----			Vessel-Relative Forces		
		Roll ----- (m.ton*m.)	Pitch (m.ton*m.)	Yaw -----	Surge ----- (m.ton)	Sway (m.ton)	Heave -----
.0	7.543E-06	0.00E-01	3.81E-06	9.25E-06	0.0	0.0	-76.6
2.5	-1.269E+01	-6.04E+00	-6.01E+00	-9.93E+00	1.9	-1.9	-76.6
5.0	-2.547E+01	-1.21E+01	-1.20E+01	-1.99E+01	3.8	-3.9	-76.6
7.5	-3.841E+01	-1.83E+01	-1.81E+01	-3.01E+01	5.7	-5.8	-76.6
10.0	-5.158E+01	-2.46E+01	-2.42E+01	-4.06E+01	7.6	-7.8	-76.6
12.5	-6.506E+01	-3.09E+01	-3.05E+01	-5.13E+01	9.4	-9.9	-76.6
15.0	-7.891E+01	-3.73E+01	-3.69E+01	-6.25E+01	11.4	-12.0	-76.5
17.5	-9.320E+01	-4.38E+01	-4.35E+01	-7.41E+01	13.3	-14.2	-76.5
20.0	-1.080E+02	-5.04E+01	-5.05E+01	-8.62E+01	15.2	-16.5	-76.3
22.5	-1.233E+02	-5.71E+01	-5.77E+01	-9.88E+01	17.1	-18.8	-76.1
25.0	-1.392E+02	-6.38E+01	-6.54E+01	-1.12E+02	19.0	-21.3	-75.7
27.5	-1.558E+02	-7.06E+01	-7.36E+01	-1.26E+02	20.9	-23.8	-75.3
30.0	-1.730E+02	-7.74E+01	-8.23E+01	-1.40E+02	22.8	-26.3	-74.7
32.5	-1.911E+02	-8.44E+01	-9.14E+01	-1.55E+02	24.7	-29.0	-74.1
35.0	-2.115E+02	-9.26E+01	-1.01E+02	-1.72E+02	26.9	-31.9	-73.7

***** V. Oblique Axis Rotational Offset Characteristics *****

```

:-----:
::
::          Offset Type: Oblique Axis Rotation      ::
::          ::
::          Axis Direction (Gx,Gy,Gz) = ( 1.00, 1.00, 1.00)  ::
::          Rotation Sense = 1. (Advancing right-handed screw)  ::
::          ::
:-----:

```

Moments reported about Vessel coordinate
(Vx,Vy,Vz) = (0.000E-01, 0.000E-01, 0.000E-01)

Offset (deg)	<--- Vessel-Relative Forces --->			<--- Vessel-Relative Moments --->		
	Fvx ----- (m.ton)	Fvy (m.ton)	Fvz -----	Mvx ----- (m.ton*m.)	Mvy (m.ton*m.)	Mvz -----
.0	0.2384E-05	0.1907E-05	-.7661E+02	0.0000E+00	0.3815E-05	0.9250E-05
2.5	0.1895E+01	-.1913E+01	-.7661E+02	-.6037E+01	-.6014E+01	-.9927E+01
5.0	0.3782E+01	-.3850E+01	-.7662E+02	-.1213E+02	-.1203E+02	-.1995E+02
7.5	0.5666E+01	-.5822E+01	-.7663E+02	-.1830E+02	-.1808E+02	-.3014E+02
10.0	0.7554E+01	-.7838E+01	-.7662E+02	-.2455E+02	-.2420E+02	-.4058E+02
12.5	0.9449E+01	-.9906E+01	-.7660E+02	-.3089E+02	-.3045E+02	-.5135E+02
15.0	0.1135E+02	-.1203E+02	-.7655E+02	-.3732E+02	-.3687E+02	-.6249E+02
17.5	0.1326E+02	-.1423E+02	-.7645E+02	-.4383E+02	-.4352E+02	-.7408E+02
20.0	0.1518E+02	-.1649E+02	-.7630E+02	-.5041E+02	-.5046E+02	-.8616E+02
22.5	0.1710E+02	-.1884E+02	-.7606E+02	-.5707E+02	-.5774E+02	-.9877E+02
25.0	0.1902E+02	-.2126E+02	-.7574E+02	-.6380E+02	-.6543E+02	-.1119E+03
27.5	0.2092E+02	-.2375E+02	-.7531E+02	-.7056E+02	-.7358E+02	-.1256E+03
30.0	0.2281E+02	-.2633E+02	-.7475E+02	-.7737E+02	-.8225E+02	-.1399E+03
32.5	0.2471E+02	-.2899E+02	-.7410E+02	-.8442E+02	-.9145E+02	-.1551E+03
35.0	0.2686E+02	-.3189E+02	-.7367E+02	-.9265E+02	-.1013E+03	-.1724E+03

***** V. Oblique Axis Rotational Offset Characteristics *****

```

:-----:
:         Offset Type: Oblique Axis Rotation         :
:         Axis Direction (Gx,Gy,Gz) = ( 1.00, 1.00, 1.00) :
:         Rotation Sense = 1. (Advancing right-handed screw) :
:-----:

```

Moments reported about Vessel coordinate
(Vx,Vy,Vz) = (0.000E-01, 0.000E-01, 0.000E-01)

>>> Raw Mooring Stiffness matrix in vessel-bound system (Vx, Vy, Vz)

dFx/dx	dFy/dx	dFz/dx	dMx/dx	dMy/dx	dMz/dx
dFx/dy	dFy/dy	dFz/dy	dMx/dy	dMy/dy	dMz/dy
dFx/dz	dFy/dz	dFz/dz	dMx/dz	dMy/dz	dMz/dz
dFx/dPx	dFy/dPx	dFz/dPx	dMx/dPx	dMy/dPx	dMz/dPx
dFx/dPy	dFy/dPy	dFz/dPy	dMx/dPy	dMy/dPy	dMz/dPy
dFx/dPz	dFy/dPz	dFz/dPz	dMx/dPz	dMy/dPz	dMz/dPz

Column =>	1	2	3	4	5	6
Row v	Offset Value = .00 deg					
1	-.6602E+01	-.1431E-04	0.0000E+00	-.3815E-04	-.2896E+02	0.5946E-04
2	-.1431E-04	-.6602E+01	-.3815E-04	0.2893E+02	-.7629E-04	-.8054E-04
3	-.1359E-03	-.2480E-03	-.5734E-01	0.1183E-02	-.6866E-03	-.3412E-04
4	0.1366E-03	-.5243E+02	0.4590E-01	-.3400E+03	0.3278E-02	0.6006E-02
5	0.5241E+02	-.1366E-03	0.0000E+00	0.2186E-02	-.3404E+03	0.4269E-03
6	-.1366E-03	-.5464E-03	0.2186E-02	0.0000E+00	0.0000E+00	-.3933E+03

Column =>	1	2	3	4	5	6
Row v	Offset Value = 2.50 deg					
1	-.6524E+01	-.7982E-02	0.4002E-01	0.8072E+00	-.2819E+02	0.7735E+00
2	-.7336E-01	-.6467E+01	0.2914E-01	0.2773E+02	0.7322E-01	0.6850E+00
3	-.4416E-01	0.6532E-01	-.5716E+01	-.6328E+00	-.6819E+00	-.1235E+01
4	0.6228E+00	-.5251E+02	0.7278E+00	-.3395E+03	-.4843E+01	0.4749E+01
5	0.5246E+02	0.6041E+00	0.6666E+00	0.5106E+01	-.3401E+03	-.5118E+01
6	-.6385E+00	-.7582E+00	-.1467E+01	-.3615E+01	0.3643E+01	-.3941E+03

Column =>	1	2	3	4	5	6
Row v	Offset Value = 5.00 deg					
1	-.6072E+01	-.3549E+00	-.5545E+00	0.4028E+01	-.2424E+02	0.1369E+01
2	-.2697E+00	-.6097E+01	0.3421E+00	0.2463E+02	-.9514E+00	0.1316E+01
3	-.3285E+00	0.3738E+00	-.5131E+01	-.3517E+01	-.3965E+01	-.2262E+01
4	0.2298E+01	-.5457E+02	-.8262E+00	-.3244E+03	-.1261E+01	0.8720E+01
5	0.5330E+02	0.8196E-01	-.9617E-01	0.1860E+02	-.3340E+03	-.1045E+02
6	-.1294E+01	-.1516E+01	-.2684E+01	-.8535E+01	0.6442E+01	-.3963E+03

Column =>	1	2	3	4	5	6
Row v	Offset Value = 7.50 deg					
1	-.5831E+01	-.4053E+00	-.7092E+00	0.4750E+01	-.2200E+02	0.1931E+01
2	-.3852E+00	-.5910E+01	0.4765E+00	0.2299E+02	-.1334E+01	0.1874E+01
3	-.4929E+00	0.3816E+00	-.4895E+01	-.3903E+01	-.6029E+01	-.3149E+01
4	0.2911E+01	-.5491E+02	0.2229E+00	-.3238E+03	-.6456E+01	0.1244E+02
5	0.5602E+02	0.2571E+00	-.1932E+01	0.2350E+02	-.3148E+03	-.1838E+02
6	-.2489E+01	-.2452E+01	-.3272E+01	-.1255E+02	0.4639E+01	-.3993E+03

Column =>	1	2	3	4	5	6
Row v	Offset Value = 10.00 deg					
1	-.5635E+01	-.4443E+00	-.7877E+00	0.5308E+01	-.2008E+02	0.2466E+01
2	-.3582E+00	-.5793E+01	0.4816E+00	0.2168E+02	-.6681E+00	0.2204E+01
3	-.4689E+00	0.3682E+00	-.4854E+01	-.4219E+01	-.6580E+01	-.4150E+01
4	0.3518E+01	-.5528E+02	0.1340E+01	-.3227E+03	-.1156E+02	0.1618E+02
5	0.5635E+02	0.6215E+00	-.1064E+01	0.2882E+02	-.3145E+03	-.2471E+02
6	-.3228E+01	-.3563E+01	-.4188E+01	-.1630E+02	0.6028E+01	-.4035E+03

Column =>	1	2	3	4	5	6
Row v	Offset Value = 12.50 deg					
1	-.5594E+01	-.3826E+00	-.6124E+00	0.5321E+01	-.1912E+02	0.3219E+01
2	-.3285E+00	-.5691E+01	0.4776E+00	0.2035E+02	-.8871E-01	0.2389E+01
3	-.4134E+00	0.4330E+00	-.4705E+01	-.5042E+01	-.6798E+01	-.5151E+01
4	0.4127E+01	-.5572E+02	0.2573E+01	-.3209E+03	-.1648E+02	0.2008E+02
5	0.5674E+02	0.9969E+00	-.1792E+00	0.3427E+02	-.3136E+03	-.3133E+02
6	-.3919E+01	-.4733E+01	-.5079E+01	-.2001E+02	0.7176E+01	-.4084E+03

Column =>	1	2	3	4	5	6
Row v	Offset Value = 15.00 deg					
1	-.5558E+01	-.3207E+00	-.4642E+00	0.5355E+01	-.1811E+02	0.4003E+01
2	-.2961E+00	-.5599E+01	0.4668E+00	0.1900E+02	0.3986E+00	0.2431E+01
3	-.3707E+00	0.5006E+00	-.4548E+01	-.5767E+01	-.7043E+01	-.6108E+01
4	0.4548E+01	-.5645E+02	0.3508E+01	-.3163E+03	-.2280E+02	0.2430E+02
5	0.5712E+02	0.1296E+01	0.6797E+00	0.4013E+02	-.3126E+03	-.3825E+02
6	-.4572E+01	-.6131E+01	-.5882E+01	-.2308E+02	0.8032E+01	-.4140E+03

Column =>	1	2	3	4	5	6
Row v	Offset Value = 17.50 deg					
1	-.5530E+01	-.2614E+00	-.3445E+00	0.5407E+01	-.1706E+02	0.4804E+01
2	-.2621E+00	-.5521E+01	0.4525E+00	0.1765E+02	0.7875E+00	0.2336E+01
3	-.3395E+00	0.5692E+00	-.4389E+01	-.6370E+01	-.7312E+01	-.7009E+01
4	0.4332E+01	-.5866E+02	0.3049E+01	-.3013E+03	-.3444E+02	0.2996E+02
5	0.5815E+02	0.2763E+01	0.2931E+01	0.3782E+02	-.3062E+03	-.4626E+02
6	-.5109E+01	-.7255E+01	-.6170E+01	-.2835E+02	0.9920E+01	-.4204E+03

```
-----
Column => 1          2          3          4          5          6
-----
Row
|
v
          Offset Value = 20.00 deg
1  -.5526E+01  -.6473E-01  -.5191E+00  0.3831E+01  -.1693E+02  0.5230E+01
2  -.1687E+00  -.5869E+01  0.1209E+01  0.2108E+02  0.3832E+01  0.3226E+01
3  -.3767E+00  0.1018E+01  -.4942E+01  -.1123E+02  -.1015E+02  -.8865E+01
4  0.4420E+01  -.5607E+02  -.1213E+01  -.3344E+03  -.5997E+02  0.2647E+02
5  0.5836E+02  0.4788E+01  0.4852E+00  0.2366E+02  -.3167E+03  -.5885E+02
6  -.5950E+01  -.7581E+01  -.8828E+01  -.4471E+02  0.2492E+01  -.4304E+03
-----
```

```
-----
Column => 1          2          3          4          5          6
-----
Row
|
v
          Offset Value = 22.50 deg
1  -.5495E+01  -.4686E-01  -.3983E+00  0.4273E+01  -.1561E+02  0.6077E+01
2  -.1472E+00  -.5939E+01  0.1420E+01  0.2114E+02  0.4807E+01  0.3394E+01
3  -.3652E+00  0.1191E+01  -.5010E+01  -.1280E+02  -.1124E+02  -.1008E+02
4  0.5093E+01  -.5685E+02  0.4131E+00  -.3313E+03  -.6471E+02  0.3147E+02
5  0.5917E+02  0.4977E+01  0.1460E+01  0.3076E+02  -.3148E+03  -.6900E+02
6  -.6427E+01  -.9075E+01  -.9311E+01  -.4824E+02  0.2129E+01  -.4392E+03
-----
```

```
-----
Column => 1          2          3          4          5          6
-----
Row
|
v
          Offset Value = 25.00 deg
1  -.5468E+01  -.3566E-01  -.3105E+00  0.4691E+01  -.1430E+02  0.6913E+01
2  -.1457E+00  -.5873E+01  0.1349E+01  0.1945E+02  0.4646E+01  0.3032E+01
3  -.3683E+00  0.1210E+01  -.4896E+01  -.1260E+02  -.1167E+02  -.1085E+02
4  0.5735E+01  -.5759E+02  0.2197E+01  -.3277E+03  -.6932E+02  0.3688E+02
5  0.6001E+02  0.5142E+01  0.2503E+01  0.3820E+02  -.3126E+03  -.7947E+02
6  -.6991E+01  -.1068E+02  -.9680E+01  -.5128E+02  0.1093E+01  -.4483E+03
-----
```

```
-----
Column => 1          2          3          4          5          6
-----
Row
|
v
          Offset Value = 27.50 deg
1  -.5745E+01  -.1022E+00  -.8311E+00  0.5271E+01  -.1701E+02  0.8030E+01
2  -.1115E+00  -.5812E+01  0.1355E+01  0.1779E+02  0.4868E+01  0.2524E+01
3  -.6441E+00  0.1203E+01  -.5282E+01  -.1234E+02  -.1565E+02  -.1127E+02
4  0.6300E+01  -.5835E+02  0.4094E+01  -.3235E+03  -.7385E+02  0.4265E+02
5  0.5860E+02  0.4884E+01  -.6251E+00  0.4634E+02  -.3406E+03  -.8798E+02
6  -.8060E+01  -.1244E+02  -.1069E+02  -.5388E+02  -.6122E+01  -.4570E+03
-----
```

```
-----
Column => 1          2          3          4          5          6
-----
Row
|
v
          Offset Value = 30.00 deg
1  -.6089E+01  -.1136E+00  -.1233E+01  0.5789E+01  -.1973E+02  0.9547E+01
2  -.9074E-01  -.5763E+01  0.1346E+01  0.1619E+02  0.4821E+01  0.1932E+01
3  -.9089E+00  0.1202E+01  -.5654E+01  -.1202E+02  -.1947E+02  -.1158E+02
4  0.6848E+01  -.5922E+02  0.6100E+01  -.3193E+03  -.7832E+02  0.5003E+02
5  0.5813E+02  0.4735E+01  -.2391E+01  0.5454E+02  -.3592E+03  -.9752E+02
6  -.8786E+01  -.1412E+02  -.1075E+02  -.5627E+02  -.8139E+01  -.4671E+03
-----
```

```
-----
Column => 1          2          3          4          5          6
-----
Row
|
v
          Offset Value = 32.50 deg
1  -.6306E+01  0.4616E-02  -.1047E+01  0.6219E+01  -.1918E+02  0.1139E+02
2  0.1460E-01  -.5792E+01  0.1233E+01  0.1464E+02  0.4803E+01  0.8172E+00
3  -.9301E+00  0.1248E+01  -.5538E+01  -.1165E+02  -.1971E+02  -.1205E+02
4  0.7300E+01  -.6004E+02  0.8233E+01  -.3146E+03  -.8277E+02  0.5791E+02
5  0.5904E+02  0.4745E+01  -.1191E+01  0.6334E+02  -.3573E+03  -.1085E+03
6  -.9616E+01  -.1585E+02  -.1059E+02  -.5830E+02  -.1020E+02  -.4769E+03
-----
```

```
-----
Column => 1          2          3          4          5          6
-----
Row
|
v
          Offset Value = 35.00 deg
1  -.6574E+01  0.1681E+00  -.8758E+00  0.6565E+01  -.1865E+02  0.1353E+02
2  0.2556E+00  -.6186E+01  0.1544E+01  0.1636E+02  0.7232E+01  -.1588E+00
3  -.8343E+00  0.1517E+01  -.6032E+01  -.1480E+02  -.2177E+02  -.1398E+02
4  0.7717E+01  -.6083E+02  0.1051E+02  -.3098E+03  -.8733E+02  0.6588E+02
5  0.5956E+02  0.4948E+01  0.2557E+00  0.7223E+02  -.3574E+03  -.1185E+03
6  -.7546E+01  -.1957E+02  -.1194E+02  -.5991E+02  -.1211E+01  -.5002E+03
-----
```

***** Total Fairlead Line Tensions *****
 (m.ton)

```

:::
::
::          Offset Type: Oblique Axis Rotation          ::
:::
::      Axis Direction (Gx,Gy,Gz) = ( 1.00, 1.00, 1.00)  ::
::      Rotation Sense = 1. (Advancing right-handed screw)  ::
:::
    
```

Line #:	1	2	3	4	5	6
Offset (deg)						
.00	15.60	15.60	15.60	15.60	15.60	15.60
2.50	15.58	15.64	15.69	15.66	15.59	15.56
5.00	15.59	15.70	15.82	15.74	15.57	15.54
7.50	15.64	15.80	15.99	15.83	15.56	15.56
10.00	15.73	15.93	16.19	15.93	15.56	15.62
12.50	15.86	16.10	16.42	16.04	15.55	15.70
15.00	16.02	16.29	16.68	16.17	15.55	15.82
17.50	16.23	16.51	16.98	16.31	15.55	15.98
20.00	16.48	16.76	17.30	16.46	15.55	16.17
22.50	16.76	17.03	17.65	16.62	15.56	16.40
25.00	17.08	17.33	18.02	16.80	15.56	16.66
27.50	17.44	17.65	18.42	16.98	15.57	16.96
30.00	17.83	18.00	18.84	17.17	15.59	17.29
32.50	18.31	18.37	19.30	17.37	15.60	17.66
35.00	19.01	18.76	19.96	17.58	15.62	18.17

***** VI. Vertical Offset Restoring Characteristics *****

```

:::
::
::      Offset Type: Rectilinear Vertical Translation    ::
:::
    
```

Moments reported about Vessel coordinate
 (Vx,Vy,Vz) = (0.000E-01, 0.000E-01, 0.000E-01)

---- Most Exposed Line Characteristics ----

Offset (m.)	Line #	-- Fairlead Tensions --			Unstretched Suspended Length (m.)	Anchor Forces Rel. to Bottom		Total Restoring Force (m.ton)
		Total (m.ton)	Horiz. (m.ton)	Vert. (m.ton)		<Parallel> (m.ton)	<Perp.> (m.ton)	
-10.0	1	6.73	2.24	-6.35	30.4	2.24	-0.00	-3.811E+01
-9.0	1	7.39	2.69	-6.91	32.9	2.69	-0.00	-4.146E+01
-8.0	1	8.09	3.18	-7.43	35.6	3.18	-0.00	-4.458E+01
-7.0	1	8.86	3.75	-8.05	38.4	3.75	-0.00	-4.829E+01
-6.0	1	9.65	4.32	-8.63	41.3	4.32	-0.00	-5.179E+01
-5.0	1	10.50	4.97	-9.29	44.3	4.97	-0.00	-5.575E+01
-4.0	1	11.43	5.69	-9.96	47.4	5.69	-0.00	-5.977E+01
-3.0	1	12.34	6.39	-10.55	50.5	6.39	-0.00	-6.330E+01
-2.0	1	13.46	7.30	-11.37	54.0	7.30	-0.00	-6.819E+01
-1.0	1	14.50	8.13	-12.05	57.4	8.13	-0.00	-7.228E+01
.0	1	15.60	9.02	-12.77	60.9	9.02	-0.00	-7.661E+01
1.0	1	16.92	10.14	-13.64	64.8	10.14	-0.00	-8.184E+01
2.0	1	18.16	11.17	-14.37	68.5	11.17	-0.00	-8.625E+01
3.0	1	19.43	12.23	-15.12	72.3	12.23	-0.00	-9.071E+01
4.0	1	20.97	13.56	-16.11	76.5	13.56	-0.00	-9.667E+01

***** VI. Vertical Offset Restoring Characteristics *****

```

:
:
: Offset Type: Rectilinear Vertical Translation
:
:
:
:

```

Moments reported about Vessel coordinate
(Vx,Vy,Vz) = (0.000E-01, 0.000E-01, 0.000E-01)

Total Restoring Characteristics
and Cross-Coupling Summary

Offset (m.)	Total Restoring Force (m.ton)	---- Induced Moments ----			---- Vessel-Relative Forces ----			
		Roll	Pitch	Yaw	Orthogonal to Offset	Surge	Sway	Heave
		----- (m.ton*m.) -----			----- (m.ton)-----			
-10.0	-38.1	0.00E-01	0.00E-01	5.27E-06	0.0	0.0	0.0	-38.1
-9.0	-41.5	0.00E-01	0.00E-01	4.99E-06	0.0	0.0	0.0	-41.5
-8.0	-44.6	0.00E-01	0.00E-01	6.60E-06	0.0	0.0	0.0	-44.6
-7.0	-48.3	0.00E-01	0.00E-01	6.24E-06	0.0	0.0	0.0	-48.3
-6.0	-51.8	0.00E-01	0.00E-01	8.74E-06	0.0	0.0	0.0	-51.8
-5.0	-55.8	0.00E-01	0.00E-01	9.29E-06	0.0	0.0	0.0	-55.8
-4.0	-59.8	0.00E-01	0.00E-01	1.17E-05	0.0	0.0	0.0	-59.8
-3.0	-63.3	0.00E-01	-7.63E-06	1.13E-05	0.0	0.0	0.0	-63.3
-2.0	-68.2	0.00E-01	0.00E-01	1.45E-05	0.0	0.0	0.0	-68.2
-1.0	-72.3	0.00E-01	0.00E-01	1.78E-05	0.0	0.0	0.0	-72.3
.0	-76.6	0.00E-01	0.00E-01	2.11E-05	0.0	0.0	0.0	-76.6
1.0	-81.8	0.00E-01	0.00E-01	2.23E-05	0.0	0.0	0.0	-81.8
2.0	-86.2	0.00E-01	0.00E-01	2.35E-05	0.0	0.0	0.0	-86.2
3.0	-90.7	0.00E-01	0.00E-01	2.67E-05	0.0	0.0	0.0	-90.7
4.0	-96.7	0.00E-01	0.00E-01	2.59E-05	0.0	0.0	0.0	-96.7

***** VI. Vertical Offset Restoring Characteristics *****

```

:
:
: Offset Type: Rectilinear Vertical Translation
:
:
:
:

```

Moments reported about Vessel coordinate
(Vx,Vy,Vz) = (0.000E-01, 0.000E-01, 0.000E-01)

Offset (m.)	<--- Vessel-Relative Forces --->			<--- Vessel-Relative Moments --->		
	Fvx	Fvy	Fvz	Mvx	Mvy	Mvz
	----- (m.ton) -----			----- (m.ton*m.) -----		
-10.0	0.5960E-06	0.5960E-06	-.3811E+02	0.0000E+00	0.0000E+00	0.5274E-05
-9.0	0.7153E-06	0.2384E-06	-.4146E+02	0.0000E+00	0.0000E+00	0.4995E-05
-8.0	0.2384E-06	0.9537E-06	-.4458E+02	0.0000E+00	0.0000E+00	0.6597E-05
-7.0	0.5960E-06	0.7153E-06	-.4829E+02	0.0000E+00	0.0000E+00	0.6242E-05
-6.0	0.4768E-06	0.9537E-06	-.5179E+02	0.0000E+00	0.0000E+00	0.8743E-05
-5.0	0.1192E-05	0.4768E-06	-.5575E+02	0.0000E+00	0.0000E+00	0.9295E-05
-4.0	0.1431E-05	0.1431E-05	-.5977E+02	0.0000E+00	0.0000E+00	0.1170E-04
-3.0	0.9537E-06	0.1431E-05	-.6330E+02	0.0000E+00	-.7629E-05	0.1127E-04
-2.0	0.1192E-05	0.1907E-05	-.6819E+02	0.0000E+00	0.0000E+00	0.1451E-04
-1.0	0.9537E-06	0.1907E-05	-.7228E+02	0.0000E+00	0.0000E+00	0.1781E-04
.0	0.1431E-05	0.2384E-05	-.7661E+02	0.0000E+00	0.0000E+00	0.2107E-04
1.0	0.2384E-05	0.1907E-05	-.8184E+02	0.0000E+00	0.0000E+00	0.2228E-04
2.0	0.9537E-06	0.3815E-05	-.8625E+02	0.0000E+00	0.0000E+00	0.2354E-04
3.0	0.1907E-05	0.3815E-05	-.9071E+02	0.0000E+00	0.0000E+00	0.2670E-04
4.0	0.9537E-06	0.3815E-05	-.9667E+02	0.0000E+00	0.0000E+00	0.2586E-04

***** VI. Vertical Offset Restoring Characteristics *****

```

:-----:
:         :
: Offset Type: Rectilinear Vertical Translation :
:         :
:         :
:         :
:-----:
    
```

Moments reported about Vessel coordinate
 (Vx,Vy,Vz) = (0.000E-01, 0.000E-01, 0.000E-01)

>>> Raw Mooring Stiffness matrix in vessel-bound system (Vx, Vy, Vz)

dFx/dx	dFy/dx	dFz/dx	dMx/dx	dMy/dx	dMz/dx
dFx/dy	dFy/dy	dFz/dy	dMx/dy	dMy/dy	dMz/dy
dFx/dz	dFy/dz	dFz/dz	dMx/dz	dMy/dz	dMz/dz
dFx/dPx	dFy/dPx	dFz/dPx	dMx/dPx	dMy/dPx	dMz/dPx
dFx/dPy	dFy/dPy	dFz/dPy	dMx/dPy	dMy/dPy	dMz/dPy
dFx/dPz	dFy/dPz	dFz/dPz	dMx/dPz	dMy/dPz	dMz/dPz

 Column => 1 2 3 4 5 6

Row
 |
 v Offset Value = -10.00 m.

1	-.1673E+01	0.0000E+00	0.0000E+00	0.0000E+00	-.7266E+01	-.3446E-06
2	-.1192E-05	-.1673E+01	0.0000E+00	0.7260E+01	-.1907E-04	-.2468E-04
3	0.0000E+00	0.0000E+00	-.2900E+01	0.0000E+00	0.1907E-04	-.2622E-05
4	0.0000E+00	-.2990E+02	0.0000E+00	-.1222E+03	0.0000E+00	0.2753E-03
5	0.2987E+02	0.0000E+00	0.0000E+00	0.0000E+00	-.1224E+03	0.0000E+00
6	0.3415E-04	-.1708E-03	0.0000E+00	0.0000E+00	0.0000E+00	-.9779E+02

 Column => 1 2 3 4 5 6

Row
 |
 v Offset Value = -9.00 m.

1	-.2210E+01	0.0000E+00	0.0000E+00	0.0000E+00	-.1180E+02	0.1385E-04
2	-.1192E-05	-.2210E+01	0.0000E+00	0.1179E+02	-.1907E-04	-.3914E-04
3	0.1192E-05	0.2384E-05	-.3509E+01	0.0000E+00	0.3815E-04	-.3166E-06
4	-.6830E-04	-.3051E+02	0.0000E+00	-.1473E+03	-.2186E-02	-.2711E-03
5	0.3049E+02	-.6830E-04	0.1093E-02	0.0000E+00	-.1475E+03	0.0000E+00
6	0.0000E+00	-.2049E-03	0.1093E-02	0.0000E+00	0.1093E-02	-.1173E+03

 Column => 1 2 3 4 5 6

Row
 |
 v Offset Value = -8.00 m.

1	-.2116E+01	0.0000E+00	0.1907E-04	0.0000E+00	-.8085E+01	0.9099E-05
2	-.1788E-05	-.2116E+01	0.0000E+00	0.8079E+01	0.0000E+00	-.3714E-04
3	0.1192E-05	0.0000E+00	-.2799E+01	0.0000E+00	-.1907E-04	-.2887E-06
4	0.6830E-04	-.3457E+02	0.0000E+00	-.1397E+03	-.1093E-02	0.2732E-03
5	0.3457E+02	0.6830E-04	-.1093E-02	0.0000E+00	-.1398E+03	0.2689E-03
6	0.0000E+00	-.2732E-03	0.0000E+00	0.0000E+00	0.0000E+00	-.1386E+03

 Column => 1 2 3 4 5 6

Row
 |
 v Offset Value = -7.00 m.

1	-.2852E+01	0.0000E+00	0.0000E+00	0.0000E+00	-.1393E+02	0.4182E-05
2	-.5960E-06	-.2852E+01	-.1907E-04	0.1392E+02	-.1907E-04	-.4990E-04
3	0.5960E-06	0.0000E+00	-.3870E+01	0.0000E+00	-.1907E-04	-.3725E-06
4	-.6830E-04	-.3538E+02	0.0000E+00	-.1792E+03	0.0000E+00	0.2711E-03
5	0.3536E+02	0.0000E+00	0.1093E-02	0.0000E+00	-.1795E+03	-.2732E-03
6	-.3415E-04	-.3415E-03	0.0000E+00	0.0000E+00	0.0000E+00	-.1634E+03

 Column => 1 2 3 4 5 6

Row
 |
 v Offset Value = -6.00 m.

1	-.2732E+01	0.0000E+00	0.0000E+00	0.0000E+00	-.1001E+02	0.4210E-05
2	-.1192E-05	-.2732E+01	0.0000E+00	0.1000E+02	0.0000E+00	-.5319E-04
3	0.2384E-05	0.1192E-05	-.3182E+01	0.0000E+00	-.1907E-04	0.9192E-05
4	0.0000E+00	-.3998E+02	0.0000E+00	-.1740E+03	0.0000E+00	-.2732E-03
5	0.4000E+02	-.6830E-04	0.0000E+00	0.0000E+00	-.1741E+03	-.2775E-03
6	0.6830E-04	-.2049E-03	0.0000E+00	0.0000E+00	0.0000E+00	-.1884E+03

 Column => 1 2 3 4 5 6

Row
 |
 v Offset Value = -5.00 m.

1	-.3752E+01	-.2384E-05	0.0000E+00	0.0000E+00	-.1814E+02	-.1032E-04
2	-.2384E-05	-.3752E+01	0.0000E+00	0.1813E+02	0.0000E+00	-.4255E-04
3	-.2384E-05	0.0000E+00	-.4535E+01	0.0000E+00	0.0000E+00	-.4563E-06
4	0.0000E+00	-.4021E+02	0.1093E-02	-.2224E+03	0.0000E+00	-.5528E-03
5	0.4023E+02	0.0000E+00	-.2186E-02	0.0000E+00	-.2225E+03	0.2689E-03
6	-.1366E-03	-.2732E-03	0.1093E-02	0.0000E+00	0.0000E+00	-.2166E+03

 Column => 1 2 3 4 5 6

Row
 |
 v Offset Value = -4.00 m.

1	-.3600E+01	0.4768E-05	0.0000E+00	0.0000E+00	-.1349E+02	-.7451E-06
2	-.1192E-05	-.3600E+01	-.3815E-04	0.1348E+02	0.0000E+00	-.8000E-04
3	-.4768E-05	0.2384E-05	-.3586E+01	0.0000E+00	0.3815E-04	0.9099E-05
4	0.0000E+00	-.4472E+02	0.2186E-02	-.2135E+03	0.0000E+00	-.1644E-02
5	0.4469E+02	0.0000E+00	0.0000E+00	0.0000E+00	-.2138E+03	-.5507E-03
6	-.2049E-03	-.1366E-03	0.2186E-02	0.0000E+00	0.4371E-02	-.2480E+03

 Column => 1 2 3 4 5 6

Row
 |
 v Offset Value = -3.00 m.

1	-.4813E+01	0.0000E+00	0.0000E+00	0.0000E+00	-.2282E+02	-.1051E-04
2	-.3576E-05	-.4775E+01	0.0000E+00	0.2243E+02	0.0000E+00	-.9354E-04
3	0.0000E+00	-.2384E-05	-.5391E+01	0.0000E+00	-.3815E-04	-.1967E-04
4	-.1366E-03	-.4304E+02	0.0000E+00	-.2748E+03	0.0000E+00	-.1093E-02
5	0.4301E+02	0.1366E-03	0.0000E+00	0.0000E+00	-.2753E+03	0.1089E-02
6	-.1366E-03	-.5464E-03	0.0000E+00	0.0000E+00	0.2186E-02	-.2787E+03

```
-----
Column => 1          2          3          4          5          6
-----
Row
|
v
Offset Value = -2.00 m.

1  -.4833E+01  0.0000E+00  0.0000E+00  0.0000E+00  -.1924E+02  0.8540E-05
2  -.1192E-05  -.4833E+01  0.3815E-04  0.1922E+02  0.0000E+00  -.8918E-04
3  0.0000E+00  0.2384E-05  -.4446E+01  0.0000E+00  0.0000E+00  0.8978E-05
4  -.1366E-03  -.4956E+02  0.0000E+00  -.2701E+03  0.0000E+00  0.0000E+00
5  0.4956E+02  0.0000E+00  0.0000E+00  0.0000E+00  -.2704E+03  0.5464E-03
6  -.1366E-03  -.6830E-03  -.2186E-02  0.0000E+00  0.0000E+00  -.3182E+03
-----
```

```
-----
Column => 1          2          3          4          5          6
-----
Row
|
v
Offset Value = -1.00 m.

1  -.4650E+01  0.0000E+00  0.0000E+00  0.0000E+00  -.1481E+02  0.8568E-05
2  -.4768E-05  -.4650E+01  0.0000E+00  0.1480E+02  0.7629E-04  -.1130E-03
3  0.0000E+00  0.0000E+00  -.3759E+01  0.0000E+00  0.0000E+00  -.4843E-06
4  0.0000E+00  -.5506E+02  -.2186E-02  -.2705E+03  0.0000E+00  0.5421E-03
5  0.5509E+02  0.0000E+00  0.0000E+00  0.0000E+00  -.2707E+03  0.5379E-03
6  0.1366E-03  -.4098E-03  0.0000E+00  0.0000E+00  0.0000E+00  -.3546E+03
-----
```

```
-----
Column => 1          2          3          4          5          6
-----
Row
|
v
Offset Value = .00 m.

1  -.6602E+01  -.7153E-05  0.0000E+00  0.0000E+00  -.2896E+02  0.8158E-05
2  -.2384E-05  -.6602E+01  0.0000E+00  0.2893E+02  -.3815E-04  -.1276E-03
3  -.4768E-05  0.0000E+00  -.5734E+01  0.0000E+00  -.3815E-04  0.1838E-04
4  0.0000E+00  -.5249E+02  -.2186E-02  -.3398E+03  0.0000E+00  -.5421E-03
5  0.5241E+02  0.0000E+00  0.0000E+00  0.0000E+00  -.3404E+03  0.0000E+00
6  -.4098E-03  -.6830E-03  0.0000E+00  0.0000E+00  -.2186E-02  -.3933E+03
-----
```

```
-----
Column => 1          2          3          4          5          6
-----
Row
|
v
Offset Value = 1.00 m.

1  -.6356E+01  0.0000E+00  0.0000E+00  0.0000E+00  -.2290E+02  -.1088E-04
2  0.0000E+00  -.6356E+01  -.3815E-04  0.2289E+02  0.0000E+00  -.1530E-03
3  -.4768E-05  0.0000E+00  -.4779E+01  0.0000E+00  0.0000E+00  0.8866E-05
4  -.5464E-03  -.5890E+02  -.2186E-02  -.3394E+03  -.4371E-02  0.2186E-02
5  0.5887E+02  -.2732E-03  0.0000E+00  0.0000E+00  -.3398E+03  -.8538E-05
6  -.2732E-03  -.8196E-03  0.0000E+00  0.0000E+00  0.4371E-02  -.4419E+03
-----
```

```
-----
Column => 1          2          3          4          5          6
-----
Row
|
v
Offset Value = 2.00 m.

1  -.6129E+01  -.4768E-05  0.0000E+00  0.0000E+00  -.1806E+02  -.1267E-05
2  -.4768E-05  -.6129E+01  0.0000E+00  0.1805E+02  0.0000E+00  -.1207E-03
3  0.9537E-05  0.4768E-05  -.4061E+01  0.0000E+00  0.0000E+00  0.3753E-04
4  -.2732E-03  -.6501E+02  0.2186E-02  -.3431E+03  0.0000E+00  0.1093E-02
5  0.6498E+02  0.0000E+00  0.0000E+00  0.0000E+00  -.3435E+03  -.1093E-02
6  -.4098E-03  -.2732E-03  0.0000E+00  0.0000E+00  0.0000E+00  -.4868E+03
-----
```

```
-----
Column => 1          2          3          4          5          6
-----
Row
|
v
Offset Value = 3.00 m.

1  -.8818E+01  0.9537E-05  0.0000E+00  0.0000E+00  -.3619E+02  -.1825E-05
2  -.4768E-05  -.8818E+01  0.0000E+00  0.3616E+02  -.3815E-04  -.1649E-03
3  0.0000E+00  -.4768E-05  -.6442E+01  0.0000E+00  -.3815E-04  -.1993E-04
4  0.2732E-03  -.6115E+02  -.2186E-02  -.4266E+03  -.2186E-02  -.4269E-05
5  0.6117E+02  0.0000E+00  0.0000E+00  0.0000E+00  -.4269E+03  -.8538E-05
6  0.4098E-03  -.5464E-03  0.0000E+00  0.0000E+00  0.0000E+00  -.5331E+03
-----
```

```
-----
Column => 1          2          3          4          5          6
-----
Row
|
v
Offset Value = 4.00 m.

1  -.8514E+01  0.0000E+00  0.0000E+00  0.0000E+00  -.2963E+02  -.1732E-05
2  -.2384E-05  -.8514E+01  0.0000E+00  0.2961E+02  0.7629E-04  -.1725E-03
3  0.2384E-05  0.0000E+00  -.5515E+01  0.0000E+00  0.3815E-04  0.1825E-04
4  0.0000E+00  -.6918E+02  0.0000E+00  -.4316E+03  0.0000E+00  0.1093E-02
5  0.6915E+02  0.2732E-03  0.0000E+00  0.0000E+00  -.4321E+03  0.1084E-02
6  0.1366E-03  -.5464E-03  0.2186E-02  0.0000E+00  0.2186E-02  -.5911E+03
-----
```

***** Total Fairlead Line Tensions *****
(m.ton)

```

:-----:
::
:: Offset Type: Rectilinear Vertical Translation ::
::
:-----:

```

Line #:	1	2	3	4	5	6
Offset (m.)						
-10.00	6.73	6.73	6.73	6.73	6.73	6.73
-9.00	7.39	7.39	7.39	7.39	7.39	7.39
-8.00	8.09	8.09	8.09	8.09	8.09	8.09
-7.00	8.86	8.86	8.86	8.86	8.86	8.86
-6.00	9.65	9.65	9.65	9.65	9.65	9.65
-5.00	10.50	10.50	10.50	10.50	10.50	10.50
-4.00	11.43	11.43	11.43	11.43	11.43	11.43
-3.00	12.34	12.34	12.34	12.34	12.34	12.34
-2.00	13.46	13.46	13.46	13.46	13.46	13.46
-1.00	14.50	14.50	14.50	14.50	14.50	14.50
.00	15.60	15.60	15.60	15.60	15.60	15.60
1.00	16.92	16.92	16.92	16.92	16.92	16.92
2.00	18.16	18.16	18.16	18.16	18.16	18.16
3.00	19.43	19.43	19.43	19.43	19.43	19.43
4.00	20.97	20.97	20.97	20.97	20.97	20.97

***** VII. Oblique Rectilinear Offset Characteristics *****

```

:-----:
::
:: Offset Type: Rectilinear Oblique Translation ::
::
:: Offset Direction (Gx,Gy,Gz) = ( 1.00, 1.00, 1.00) ::
:-----:

```

Moments reported about Vessel coordinate
(Vx,Vy,Vz) = (0.000E-01, 0.000E-01, 0.000E-01)

---- Most Exposed Line Characteristics ----

Offset (m.)	Line #	-- Fairlead Tensions --			Unstretched Suspended Length (m.)	Anchor Forces Rel. to Bottom		Total Restoring Force (m.ton)
		Total (m.ton)	Horiz. (m.ton)	Vert. (m.ton)		<Parallel> (m.ton)	<Perp.> (m.ton)	
.0	1	15.60	9.02	-12.77	60.9	9.02	-0.00	-4.423E+01
1.0	5	18.05	11.36	-14.08	67.1	11.36	-0.00	-5.008E+01
2.0	5	21.24	14.43	-15.70	74.5	14.43	-0.00	-5.676E+01
3.0	5	25.21	18.27	-17.48	83.0	18.27	-0.00	-6.438E+01
4.0	5	30.16	23.10	-19.41	92.7	23.10	-0.00	-7.372E+01
5.0	5	37.05	29.87	-21.98	104.8	29.87	-0.00	-8.487E+01
6.0	5	46.50	39.21	-25.17	119.5	39.21	-0.00	-9.971E+01
7.0	5	59.33	51.92	-28.97	137.2	51.92	-0.00	-1.184E+02
8.0	5	77.06	69.52	-33.54	158.7	69.52	-0.00	-1.421E+02
9.0	5	102.03	94.38	-39.12	185.1	94.38	-0.00	-1.743E+02
10.0	5	136.83	129.06	-45.86	217.0	129.06	-0.00	-2.167E+02
11.0	5	184.20	176.31	-53.79	254.5	176.31	-0.00	-2.714E+02
12.0	5	246.01	238.01	-62.75	297.0	238.01	-0.00	-3.425E+02
13.0	5	322.26	314.14	-72.34	343.1	314.14	-0.00	-4.289E+02
14.0	5	410.82	402.60	-81.90	391.2	402.60	.02	-5.285E+02

***** VII. Oblique Rectilinear Offset Characteristics *****

```

:-----:
:      Offset Type: Rectilinear Oblique Translation      :
:-----:
:      Offset Direction (Gx,Gy,Gz) = ( 1.00, 1.00, 1.00) :
:-----:

```

Moments reported about Vessel coordinate
(Vx,Vy,Vz) = (0.000E-01, 0.000E-01, 0.000E-01)

Total Restoring Characteristics
and Cross-Coupling Summary

Offset (m.)	Total Restoring Force (m.ton)	---- Induced Moments ----			---- Vessel-Relative Forces ----			
		Roll	Pitch	Yaw	Orthogonal to Offset	Surge	Sway	Heave
		(m.ton*m.)			(m.ton)			
.0	-44.2	0.00E-01	0.00E-01	2.11E-05	62.6	0.0	0.0	-76.6
1.0	-50.1	1.30E+01	-1.31E+01	1.26E-03	62.1	-3.6	-3.5	-79.6
2.0	-56.8	2.65E+01	-2.70E+01	8.10E-03	61.7	-7.6	-7.6	-83.1
3.0	-64.4	4.16E+01	-4.19E+01	1.78E-02	60.8	-12.4	-12.3	-86.8
4.0	-73.7	5.95E+01	-5.96E+01	3.20E-02	59.6	-18.2	-18.2	-91.2
5.0	-84.9	7.89E+01	-7.80E+01	4.46E-02	57.7	-25.3	-25.6	-96.2
6.0	-99.7	1.02E+02	-1.04E+02	9.72E-02	54.9	-35.2	-35.2	-102.4
7.0	-118.4	1.32E+02	-1.31E+02	1.02E-01	50.5	-47.4	-48.1	-109.6
8.0	-142.1	1.65E+02	-1.63E+02	8.46E-02	43.4	-63.3	-65.3	-117.5
9.0	-174.3	2.03E+02	-2.04E+02	1.17E-01	32.7	-85.9	-88.7	-127.3
10.0	-216.7	2.52E+02	-2.48E+02	-4.85E-02	17.5	-115.1	-121.3	-139.0
11.0	-271.4	3.07E+02	-2.99E+02	-3.85E-01	9.9	-153.5	-164.7	-151.8
12.0	-342.5	3.67E+02	-3.64E+02	-6.07E-01	39.1	-205.5	-220.7	-167.0
13.0	-428.9	4.34E+02	-4.32E+02	-9.88E-01	79.8	-269.5	-289.9	-183.6
14.0	-528.5	5.01E+02	-5.01E+02	-1.33E+00	129.6	-345.1	-370.1	-200.3

***** VII. Oblique Rectilinear Offset Characteristics *****

```

:-----:
:      Offset Type: Rectilinear Oblique Translation      :
:-----:
:      Offset Direction (Gx,Gy,Gz) = ( 1.00, 1.00, 1.00) :
:-----:

```

Moments reported about Vessel coordinate
(Vx,Vy,Vz) = (0.000E-01, 0.000E-01, 0.000E-01)

Offset (m.)	<--- Vessel-Relative Forces --->			<--- Vessel-Relative Moments --->		
	Fvx	Fvy	Fvz	Mvx	Mvy	Mvz
	(m.ton)			(m.ton*m.)		
.0	0.1431E-05	0.2384E-05	-.7661E+02	0.0000E+00	0.0000E+00	0.2107E-04
1.0	-.3552E+01	-.3542E+01	-.7965E+02	0.1297E+02	-.1309E+02	0.1265E-02
2.0	-.7607E+01	-.7566E+01	-.8314E+02	0.2650E+02	-.2697E+02	0.8095E-02
3.0	-.1235E+02	-.1233E+02	-.8683E+02	0.4162E+02	-.4191E+02	0.1784E-01
4.0	-.1824E+02	-.1821E+02	-.9124E+02	0.5949E+02	-.5965E+02	0.3200E-01
5.0	-.2529E+02	-.2556E+02	-.9615E+02	0.7888E+02	-.7799E+02	0.4455E-01
6.0	-.3518E+02	-.3516E+02	-.1024E+03	0.1021E+03	-.1042E+03	0.9722E-01
7.0	-.4739E+02	-.4814E+02	-.1096E+03	0.1316E+03	-.1314E+03	0.1015E+00
8.0	-.6332E+02	-.6532E+02	-.1175E+03	0.1650E+03	-.1628E+03	0.8456E-01
9.0	-.8586E+02	-.8869E+02	-.1273E+03	0.2034E+03	-.2042E+03	0.1165E+00
10.0	-.1151E+03	-.1213E+03	-.1390E+03	0.2519E+03	-.2484E+03	-.4848E-01
11.0	-.1535E+03	-.1647E+03	-.1518E+03	0.3069E+03	-.2986E+03	-.3851E+00
12.0	-.2055E+03	-.2207E+03	-.1670E+03	0.3671E+03	-.3638E+03	-.6068E+00
13.0	-.2695E+03	-.2899E+03	-.1836E+03	0.4340E+03	-.4321E+03	-.9876E+00
14.0	-.3451E+03	-.3701E+03	-.2003E+03	0.5011E+03	-.5013E+03	-.1329E+01

***** VII. Oblique Rectilinear Offset Characteristics *****

Offset Type: Rectilinear Oblique Translation
Offset Direction (Gx,Gy,Gz) = (1.00, 1.00, 1.00)

Moments reported about Vessel coordinate
(Vx,Vy,Vz) = (0.000E-01, 0.000E-01, 0.000E-01)

>>> Raw Mooring Stiffness matrix in vessel-bound system (Vx, Vy, Vz)

dFx/dx dFy/dx dFz/dx dMx/dx dMy/dx dMz/dx
dFx/dy dFy/dy dFz/dy dMx/dy dMy/dy dMz/dy
dFx/dz dFy/dz dFz/dz dMx/dz dMy/dz dMz/dz
dFx/dPx dFy/dPx dFz/dPx dMx/dPx dMy/dPx dMz/dPx
dFx/dPy dFy/dPy dFz/dPy dMx/dPy dMy/dPy dMz/dPy
dFx/dPz dFy/dPz dFz/dPz dMx/dPz dMy/dPz dMz/dPz

Column => 1 2 3 4 5 6

Table with 6 columns and 6 rows showing stiffness matrix values for a 0.00 m offset.

Column => 1 2 3 4 5 6

Table with 6 columns and 6 rows showing stiffness matrix values for a 1.00 m offset.

Column => 1 2 3 4 5 6

Table with 6 columns and 6 rows showing stiffness matrix values for a 2.00 m offset.

Column => 1 2 3 4 5 6

Table with 6 columns and 6 rows showing stiffness matrix values for a 3.00 m offset.

Column => 1 2 3 4 5 6

Table with 6 columns and 6 rows showing stiffness matrix values for a 4.00 m offset.

Column => 1 2 3 4 5 6

Table with 6 columns and 6 rows showing stiffness matrix values for a 5.00 m offset.

Column => 1 2 3 4 5 6

Table with 6 columns and 6 rows showing stiffness matrix values for a 6.00 m offset.

Column => 1 2 3 4 5 6

Table with 6 columns and 6 rows showing stiffness matrix values for a 7.00 m offset.

```

-----
Column => 1          2          3          4          5          6
-----
Row
|
v
          Offset Value =      8.00 m.

1  -.1823E+02  -.7616E+01  -.3628E+01  0.1070E+02  -.3422E+02  -.1968E+00
2  -.7613E+01  -.2212E+02  -.4346E+01  0.4394E+02  -.1067E+02  0.3043E-01
3  -.4180E+01  -.4518E+01  -.5508E+01  0.6890E+01  -.6538E+01  -.8745E-02
4  0.9394E+01  -.7432E+02  0.7208E+02  -.7164E+03  0.1518E+03  0.1652E+03
5  0.7974E+02  -.9545E+01  -.6988E+02  0.1520E+03  -.6596E+03  0.1672E+03
6  -.6561E+02  0.6327E+02  -.6120E-01  0.2448E+01  0.1652E+01  -.1112E+04

```

```

-----
Column => 1          2          3          4          5          6
-----
Row
|
v
          Offset Value =      9.00 m.

1  -.2553E+02  -.1198E+02  -.6175E+01  0.1487E+02  -.4541E+02  -.1996E+00
2  -.1181E+02  -.2992E+02  -.6157E+01  0.5042E+02  -.1389E+02  0.2704E-02
3  -.6235E+01  -.6009E+01  -.5655E+01  0.9333E+01  -.1144E+02  0.4315E-01
4  0.1437E+02  -.7564E+02  0.9807E+02  -.8510E+03  0.2260E+03  0.2072E+03
5  0.7810E+02  -.1438E+02  -.9733E+02  0.2258E+03  -.7965E+03  0.2065E+03
6  -.8883E+02  0.8611E+02  0.9617E-01  0.2229E+01  0.2706E+01  -.1380E+04

```

```

-----
Column => 1          2          3          4          5          6
-----
Row
|
v
          Offset Value =     10.00 m.

1  -.3649E+02  -.1722E+02  -.8403E+01  0.1659E+02  -.6507E+02  -.2629E-01
2  -.1723E+02  -.4121E+02  -.8251E+01  0.6314E+02  -.1664E+02  -.1809E+00
3  -.7958E+01  -.7902E+01  -.6777E+01  0.1324E+02  -.1318E+02  0.3378E-01
4  0.1668E+02  -.7641E+02  0.1345E+03  -.1075E+04  0.3192E+03  0.2524E+03
5  0.7643E+02  -.1699E+02  -.1283E+03  0.3195E+03  -.9846E+03  0.2563E+03
6  -.1215E+03  0.1146E+03  -.4371E-01  0.4459E+01  0.4293E+01  -.1741E+04

```

```

-----
Column => 1          2          3          4          5          6
-----
Row
|
v
          Offset Value =     11.00 m.

1  -.4387E+02  -.2474E+02  -.8754E+01  0.2320E+02  -.6291E+02  -.5132E+00
2  -.2469E+02  -.5381E+02  -.9186E+01  0.6907E+02  -.2303E+02  -.2335E+00
3  -.8110E+01  -.9022E+01  -.6168E+01  0.1280E+02  -.9775E+01  -.5555E-01
4  0.2170E+02  -.8240E+02  0.1775E+03  -.1340E+04  0.4662E+03  0.3032E+03
5  0.9144E+02  -.2196E+02  -.1633E+03  0.4669E+03  -.1154E+04  0.3110E+03
6  -.1655E+03  0.1535E+03  -.1268E+00  0.4083E+01  0.3165E+01  -.2213E+04

```

```

-----
Column => 1          2          3          4          5          6
-----
Row
|
v
          Offset Value =     12.00 m.

1  -.5524E+02  -.3341E+02  -.1006E+02  0.2977E+02  -.6778E+02  -.8794E+00
2  -.3340E+02  -.6832E+02  -.1025E+02  0.7546E+02  -.2979E+02  -.2210E+00
3  -.1022E+02  -.9997E+01  -.6535E+01  0.1239E+02  -.1306E+02  0.6913E-01
4  0.2612E+02  -.9173E+02  0.2331E+03  -.1682E+04  0.6581E+03  0.3690E+03
5  0.9465E+02  -.2613E+02  -.2186E+03  0.6586E+03  -.1443E+04  0.3724E+03
6  -.2217E+03  0.2053E+03  -.4371E-02  0.4782E+01  0.4258E+01  -.2835E+04

```

```

-----
Column => 1          2          3          4          5          6
-----
Row
|
v
          Offset Value =     13.00 m.

1  -.7438E+02  -.4128E+02  -.1264E+02  0.3029E+02  -.9254E+02  -.3682E+00
2  -.4128E+02  -.8580E+02  -.1324E+02  0.9376E+02  -.3027E+02  -.5959E+00
3  -.1194E+02  -.1162E+02  -.7660E+01  0.1639E+02  -.1407E+02  0.8307E-01
4  0.2638E+02  -.9886E+02  0.3063E+03  -.2133E+04  0.8771E+03  0.4388E+03
5  0.9606E+02  -.2661E+02  -.2836E+03  0.8783E+03  -.1806E+04  0.4416E+03
6  -.2907E+03  0.2684E+03  -.1268E+00  0.7781E+01  0.7230E+01  -.3604E+04

```

```

-----
Column => 1          2          3          4          5          6
-----
Row
|
v
          Offset Value =     14.00 m.

1  -.9596E+02  -.4998E+02  -.1685E+02  0.3747E+02  -.1171E+03  0.3703E+00
2  -.4818E+02  -.9687E+02  -.1294E+02  0.9085E+02  -.3299E+02  -.2628E+00
3  -.1404E+02  -.1195E+02  -.7958E+01  0.1579E+02  -.1791E+02  0.3199E+00
4  0.2827E+02  -.1146E+03  0.3855E+03  -.2621E+04  0.1151E+04  0.5083E+03
5  0.9903E+02  -.2908E+02  -.3630E+03  0.1153E+04  -.2222E+04  0.5108E+03
6  -.3702E+03  0.3444E+03  0.3366E+00  0.7772E+01  0.1000E+02  -.4505E+04

```

***** Total Fairlead Line Tensions *****
(m.ton)

```

:-----:
:      Offset Type: Rectilinear Oblique Translation      :
:-----:
:      Offset Direction (Gx,Gy,Gz) = ( 1.00, 1.00, 1.00) :
:-----:

```

Line #:	1	2	3	4	5	6
Offset (m.)	.00	15.60	15.60	15.60	15.60	15.60
1.00	15.21	14.91	15.93	17.60	18.05	16.83
2.00	14.96	14.36	16.24	19.93	21.24	18.01
3.00	14.73	13.85	16.56	22.63	25.21	19.29
4.00	14.51	13.36	16.87	26.15	30.16	20.87
5.00	14.30	13.07	17.17	29.95	37.05	22.39
6.00	14.11	12.80	17.47	35.32	46.50	23.95
7.00	13.93	12.54	17.76	41.58	59.33	26.03
8.00	13.79	12.30	18.05	49.10	77.06	28.04
9.00	13.73	12.12	18.36	59.64	102.03	30.02
10.00	13.68	12.01	18.67	72.32	136.83	32.79
11.00	13.63	11.90	18.97	87.78	184.20	35.54
12.00	13.59	11.80	19.26	109.55	246.01	38.20
13.00	13.56	11.71	19.56	136.27	322.26	41.64
14.00	13.53	11.62	19.85	168.41	410.82	45.37

***** VIII. Continuous Equilibrium Under Specified Forcing *****

```

:-----:
:      Offset Type: Specified Force; Continuous Static Equilibrium :
:-----:
:      Global-Relative Force Direction: (Gx,Gy,Gz) = ( 1.00, 1.00, 1.00) :
:-----:
:      Force Application Point (Vx,Vy,Vz) = ( .00, .00, .00) :
:-----:

```

Moments reported about Vessel coordinate
(Vx,Vy,Vz) = (0.000E-01, 0.000E-01, 0.000E-01)

>>> Table Notes:

For "continuous offset" sequences, the "Total Restoring Force" is defined as the component of *Net* mooring force along the instantaneous offset vector. The instantaneous offset vector is *not* in general parallel to the net force vector and may also differ in direction from one offset row to the next in a sequence.

---- Most Exposed Line Characteristics ----

Offset Number	Line #	-- Fairlead Tensions -- Total (m.ton)	Horiz. (m.ton)	Vert. (m.ton)	Unstretched Suspended Length (m.)	Anchor Forces Rel. to Bottom <Parallel> (m.ton)	<Perp.> (m.ton)	Total Restoring Force (m.ton)
1.0	1	15.60	9.02	-12.77	60.9	9.02	-0.00	1.431E-06
2.0	5	15.86	9.29	-12.93	61.5	9.29	-0.00	-3.708E+00
3.0	5	16.15	9.58	-13.09	62.2	9.58	-0.00	-4.311E+00
4.0	5	16.46	9.89	-13.25	62.9	9.89	-0.00	-4.814E+00
5.0	5	16.77	10.20	-13.41	63.6	10.20	-0.00	-5.512E+00
6.0	5	17.08	10.52	-13.56	64.3	10.52	-0.00	-6.284E+00
7.0	5	17.40	10.84	-13.70	65.1	10.84	-0.00	-7.076E+00
8.0	5	17.72	11.17	-13.83	65.8	11.17	-0.00	-7.889E+00
9.0	5	18.04	11.49	-13.96	66.6	11.49	-0.00	-8.722E+00
10.0	5	18.37	11.82	-14.07	67.3	11.82	-0.00	-9.567E+00
11.0	5	18.75	12.20	-14.27	68.1	12.20	-0.00	-1.040E+01
12.0	5	19.16	12.62	-14.49	69.0	12.62	-0.00	-1.124E+01
13.0	5	19.58	13.03	-14.70	69.8	13.03	-0.00	-1.210E+01
14.0	5	19.98	13.44	-14.89	70.7	13.44	-0.00	-1.295E+01
15.0	5	20.38	13.85	-15.08	71.5	13.85	-0.00	-1.379E+01

***** VIII. Continuous Equilibrium Under Specified Forcing *****

```

:-----:
:      Offset Type: Specified Force; Continuous Static Equilibrium      :
:-----:
: Global-Relative Force Direction: (Gx,Gy,Gz) = ( 1.00, 1.00, 1.00) :
:-----:
: Force Application Point (Vx,Vy,Vz) = (   .00,   .00,   .00) :
:-----:

```

Moments reported about Vessel coordinate
(Vx,Vy,Vz) = (0.000E-01, 0.000E-01, 0.000E-01)

----- Summary of Continuous Equilibrium Offsets -----

Offset Number	Force (m.ton)	Moment (ton-meter)	C.G. Offset (m.)			Angular Offset (deg)		
			Gx	Gy	Gz	Pitch	Roll	Yaw
1	0.00E-01	0.00E-01	.000	.000	.000	-.00	.00	.00
2	1.00E+00	0.00E-01	.090	.090	.005	-.12	.12	0.00
3	2.00E+00	0.00E-01	.186	.188	.009	-.24	.24	0.00
4	3.00E+00	0.00E-01	.295	.291	.013	-.34	.34	0.00
5	4.00E+00	0.00E-01	.404	.395	.016	-.43	.45	0.00
6	5.00E+00	0.00E-01	.513	.499	.020	-.53	.55	0.00
7	6.00E+00	0.00E-01	.622	.606	.024	-.62	.65	0.00
8	7.00E+00	0.00E-01	.730	.714	.028	-.72	.74	0.00
9	8.00E+00	0.00E-01	.838	.822	.032	-.81	.84	-.01
10	9.00E+00	0.00E-01	.947	.930	.036	-.90	.93	-.01
11	1.00E+01	0.00E-01	1.047	1.024	.040	-1.00	1.04	-.01
12	1.10E+01	0.00E-01	1.144	1.113	.043	-1.10	1.15	-.01
13	1.20E+01	0.00E-01	1.242	1.201	.047	-1.21	1.27	-.01
14	1.30E+01	0.00E-01	1.335	1.290	.050	-1.31	1.37	-.02
15	1.40E+01	0.00E-01	1.419	1.382	.053	-1.42	1.48	-.02

***** VIII. Continuous Equilibrium Under Specified Forcing *****

```

:-----:
:      Offset Type: Specified Force; Continuous Static Equilibrium      :
:-----:
: Global-Relative Force Direction: (Gx,Gy,Gz) = ( 1.00, 1.00, 1.00) :
:-----:
: Force Application Point (Vx,Vy,Vz) = (   .00,   .00,   .00) :
:-----:

```

Moments reported about Vessel coordinate
(Vx,Vy,Vz) = (0.000E-01, 0.000E-01, 0.000E-01)

Total Restoring Characteristics and Cross-Coupling Summary

Offset Number	Total Restoring Force (m.ton)	Induced Moments (m.ton*m.)			Vessel-Relative Forces Orthogonal to Offset (m.ton)			
		Roll	Pitch	Yaw	Surge	Sway	Heave	
1.0	0.0	0.00E-01	0.00E-01	2.11E-05	76.6	0.0	0.0	-76.6
2.0	-3.7	2.03E+00	-2.03E+00	-7.51E-06	76.5	-.7	-.7	-76.6
3.0	-4.3	3.89E+00	-3.94E+00	1.81E-04	76.6	-1.5	-1.5	-76.7
4.0	-4.8	5.60E+00	-5.52E+00	-1.55E-05	76.7	-2.2	-2.2	-76.8
5.0	-5.5	7.29E+00	-7.07E+00	-4.33E-05	76.9	-2.9	-2.9	-77.0
6.0	-6.3	8.97E+00	-8.60E+00	-6.53E-05	77.0	-3.6	-3.7	-77.1
7.0	-7.1	1.06E+01	-1.01E+01	9.39E-04	77.1	-4.3	-4.4	-77.1
8.0	-7.9	1.21E+01	-1.17E+01	3.49E-04	77.1	-5.1	-5.1	-77.2
9.0	-8.7	1.37E+01	-1.32E+01	-4.74E-05	77.2	-5.8	-5.8	-77.3
10.0	-9.6	1.52E+01	-1.47E+01	-9.54E-06	77.2	-6.5	-6.5	-77.3
11.0	-10.4	1.70E+01	-1.63E+01	3.67E-05	77.3	-7.2	-7.3	-77.3
12.0	-11.2	1.88E+01	-1.80E+01	-6.00E-04	77.4	-8.0	-8.0	-77.4
13.0	-12.1	2.07E+01	-1.97E+01	1.66E-04	77.5	-8.7	-8.8	-77.5
14.0	-13.0	2.25E+01	-2.14E+01	1.79E-03	77.6	-9.5	-9.5	-77.6
15.0	-13.8	2.41E+01	-2.33E+01	1.11E-04	77.8	-10.2	-10.3	-77.7

***** VIII. Continuous Equilibrium Under Specified Forcing *****

Offset Type: Specified Force; Continuous Static Equilibrium
Global-Relative Force Direction: (Gx,Gy,Gz) = (1.00, 1.00, 1.00)
Force Application Point (Vx,Vy,Vz) = (.00, .00, .00)

Moments reported about Vessel coordinate
(Vx,Vy,Vz) = (0.000E-01, 0.000E-01, 0.000E-01)

Table with 7 columns: Offset Number, Fvx, Fvy, Fvz, Mvx, Mvy, Mvz. Rows 1.0 to 15.0 showing vessel-relative forces and moments in m.ton and m.ton*m.

***** VIII. Continuous Equilibrium Under Specified Forcing *****

Offset Type: Specified Force; Continuous Static Equilibrium
Global-Relative Force Direction: (Gx,Gy,Gz) = (1.00, 1.00, 1.00)
Force Application Point (Vx,Vy,Vz) = (.00, .00, .00)

Moments reported about Vessel coordinate
(Vx,Vy,Vz) = (0.000E-01, 0.000E-01, 0.000E-01)

>>> Raw Mooring Stiffness matrix in vessel-bound system (Vx, Vy, Vz)

Matrix of stiffness coefficients: dFx/dx, dFy/dx, dFz/dx, dMx/dx, dMy/dx, dMz/dx, etc.

Table for Offset Number = 1 showing stiffness matrix values for columns 1-6 and rows 1-6.

Table for Offset Number = 2 showing stiffness matrix values for columns 1-6 and rows 1-6.

Table for Offset Number = 3 showing stiffness matrix values for columns 1-6 and rows 1-6.

Column =>	1	2	3	4	5	6
Row	Offset Number = 4					
v						
1	- .5729E+01	0.2978E+00	- .9235E+00	- .2814E+01	- .2093E+02	0.1458E+00
2	0.2833E+00	- .6046E+01	- .4153E+00	0.2373E+02	0.2663E+01	- .1565E+00
3	- .4627E+00	- .2237E+00	- .4760E+01	0.1063E+01	- .3179E+01	0.1175E-01
4	- .1270E+01	- .5467E+02	0.3241E+01	- .3220E+03	- .1037E+02	0.6148E+01
5	0.5606E+02	0.1217E+01	- .5370E+01	- .1033E+02	- .3105E+03	0.6132E+01
6	- .1992E+01	0.1973E+01	0.1093E-01	0.9092E+00	0.8316E+00	- .3956E+03

Column =>	1	2	3	4	5	6
Row	Offset Number = 5					
v						
1	- .5720E+01	0.2859E+00	- .7995E+00	- .2806E+01	- .2061E+02	0.1869E+00
2	0.2282E+00	- .5954E+01	- .4288E+00	0.2274E+02	0.2276E+01	- .1914E+00
3	- .4246E+00	- .2080E+00	- .4705E+01	0.6639E+00	- .2598E+01	0.1457E-01
4	- .1283E+01	- .5482E+02	0.3366E+01	- .3222E+03	- .1040E+02	0.7905E+01
5	0.5624E+02	0.1248E+01	- .5510E+01	- .1046E+02	- .3105E+03	0.7989E+01
6	- .2638E+01	0.2612E+01	- .2186E-01	0.1226E+01	0.1099E+01	- .3971E+03

Column =>	1	2	3	4	5	6
Row	Offset Number = 6					
v						
1	- .5665E+01	0.1933E+00	- .5545E+00	- .2066E+01	- .1992E+02	0.2154E+00
2	0.1734E+00	- .5863E+01	- .4436E+00	0.2176E+02	0.1877E+01	- .2211E+00
3	- .3406E+00	- .2710E+00	- .4546E+01	0.9449E+00	- .1619E+01	0.5641E-02
4	- .1279E+01	- .5499E+02	0.3510E+01	- .3224E+03	- .1025E+02	0.9629E+01
5	0.5638E+02	0.1195E+01	- .5709E+01	- .1018E+02	- .3107E+03	0.9829E+01
6	- .3319E+01	0.3302E+01	0.3497E-01	0.1344E+01	0.1290E+01	- .3987E+03

Column =>	1	2	3	4	5	6
Row	Offset Number = 7					
v						
1	- .5605E+01	0.9251E-01	- .2959E+00	- .1224E+01	- .1919E+02	0.2355E+00
2	0.1121E+00	- .5762E+01	- .4710E+00	0.2069E+02	0.1414E+01	- .2439E+00
3	- .2517E+00	- .3444E+00	- .4379E+01	0.1310E+01	- .5910E+00	- .9531E-02
4	- .7855E-01	- .5714E+02	0.6572E+01	- .3048E+03	0.3410E+00	0.1100E+02
5	0.5726E+02	0.7650E-01	- .4201E+01	0.3300E+00	- .3048E+03	0.1143E+02
6	- .3976E+01	0.3948E+01	- .4371E-01	0.1445E+01	0.1451E+01	- .4003E+03

Column =>	1	2	3	4	5	6
Row	Offset Number = 8					
v						
1	- .5541E+01	- .8254E-02	- .3551E-01	- .3576E+00	- .1846E+02	0.2485E+00
2	0.4873E-01	- .5657E+01	- .5033E+00	0.1959E+02	0.9210E+00	- .2601E+00
3	- .1633E+00	- .4219E+00	- .4211E+01	0.1719E+01	0.4630E+00	- .3110E-01
4	- .8838E-01	- .5729E+02	0.6732E+01	- .3051E+03	0.6644E+00	0.1268E+02
5	0.5736E+02	0.8415E-01	- .4365E+01	0.6688E+00	- .3053E+03	0.1312E+02
6	- .4669E+01	0.4647E+01	- .2404E-01	0.1484E+01	0.1532E+01	- .4021E+03

Column =>	1	2	3	4	5	6
Row	Offset Number = 9					
v						
1	- .5540E+01	- .7677E-02	0.7915E-01	- .3841E+00	- .1827E+02	0.2775E+00
2	- .1303E-01	- .5554E+01	- .5347E+00	0.1852E+02	0.4272E+00	- .2703E+00
3	- .1345E+00	- .4039E+00	- .4185E+01	0.1265E+01	0.1023E+01	- .3687E-01
4	- .1052E+00	- .5739E+02	0.6902E+01	- .3057E+03	0.1029E+01	0.1431E+02
5	0.5743E+02	0.1336E+00	- .4540E+01	0.9551E+00	- .3059E+03	0.1479E+02
6	- .5296E+01	0.5281E+01	- .3497E-01	0.1799E+01	0.1856E+01	- .4038E+03

Column =>	1	2	3	4	5	6
Row	Offset Number = 10					
v						
1	- .5538E+01	- .5722E-02	0.1941E+00	- .4083E+00	- .1810E+02	0.3062E+00
2	- .1225E-01	- .5554E+01	- .4195E+00	0.1837E+02	0.4549E+00	- .2996E+00
3	- .1116E+00	- .3804E+00	- .4175E+01	0.7467E+00	0.1538E+01	- .4148E-01
4	- .1172E+00	- .5746E+02	0.7088E+01	- .3064E+03	0.1502E+01	0.1595E+02
5	0.5756E+02	0.1369E+00	- .4736E+01	0.1460E+01	- .3064E+03	0.1645E+02
6	- .5952E+01	0.5954E+01	- .3934E-01	0.1978E+01	0.2056E+01	- .4057E+03

Column =>	1	2	3	4	5	6
Row	Offset Number = 11					
v						
1	- .5760E+01	- .3867E+00	- .1385E+00	0.2282E+01	- .1951E+02	0.3195E+00
2	- .3402E+00	- .6114E+01	- .9576E+00	0.2220E+02	- .1803E+01	- .3597E+00
3	- .2892E+00	- .6996E+00	- .4561E+01	0.2709E+01	0.6207E+00	- .6437E-01
4	0.1385E+01	- .5500E+02	0.1025E+02	- .3255E+03	0.1260E+02	0.1763E+02
5	0.5676E+02	- .1321E+01	- .6640E+01	0.1258E+02	- .3133E+03	0.1788E+02
6	- .6577E+01	0.6621E+01	- .6338E-01	0.2131E+01	0.2267E+01	- .4075E+03

Column =>	1	2	3	4	5	6
Row	Offset Number = 12					
v						
1	- .5826E+01	- .5012E+00	- .1475E+00	0.2950E+01	- .1977E+02	0.3452E+00
2	- .5133E+00	- .6408E+01	- .1167E+01	0.2397E+02	- .2866E+01	- .4099E+00
3	- .3080E+00	- .7459E+00	- .4620E+01	0.2644E+01	0.8718E+00	- .7541E-01
4	0.1319E+01	- .5522E+02	0.1036E+02	- .3260E+03	0.1283E+02	0.1946E+02
5	0.5694E+02	- .1311E+01	- .6793E+01	0.1306E+02	- .3139E+03	0.1985E+02
6	- .7315E+01	0.7273E+01	- .7868E-01	0.2446E+01	0.2291E+01	- .4101E+03

Column =>	1	2	3	4	5	6
Row	Offset Number = 13					
v						
1	- .5825E+01	- .4994E+00	- .2346E-01	0.2799E+01	- .1957E+02	0.3759E+00
2	- .5130E+00	- .6409E+01	- .1036E+01	0.2363E+02	- .2709E+01	- .4439E+00
3	- .2825E+00	- .7205E+00	- .4600E+01	0.2051E+01	0.1430E+01	- .8219E-01
4	0.1279E+01	- .5538E+02	0.1046E+02	- .3266E+03	0.1329E+02	0.2126E+02
5	0.5711E+02	- .1203E+01	- .6929E+01	0.1330E+02	- .3147E+03	0.2180E+02
6	- .7977E+01	0.7923E+01	- .7650E-01	0.2771E+01	0.2588E+01	- .4127E+03

```
-----
Column => 1           2           3           4           5           6
-----
Row
|
v
Offset Number = 14
1 -.6185E+01  -.5085E+00  -.2650E+00  0.2664E+01  -.2196E+02  0.4751E+00
2  -.5136E+00  -.6410E+01  -.9055E+00  0.2332E+02  -.2567E+01  -.4784E+00
3  -.2948E+00  -.6957E+00  -.4616E+01  0.1463E+01  0.1718E+01  -.8196E-01
4  0.1229E+01  -.5556E+02  0.1061E+02  -.3273E+03  0.1376E+02  0.2293E+02
5  0.5724E+02  -.1175E+01  -.7088E+01  0.1387E+02  -.3156E+03  0.2372E+02
6  -.8706E+01  0.8590E+01  -.1005E+00  0.2940E+01  0.2660E+01  -.4153E+03
-----
```

```
-----
Column => 1           2           3           4           5           6
-----
Row
|
v
Offset Number = 15
1  -.6632E+01  -.5199E+00  -.5901E+00  0.2539E+01  -.2487E+02  0.5968E+00
2  -.4895E+00  -.6342E+01  -.9102E+00  0.2226E+02  -.2111E+01  -.5040E+00
3  -.7341E+00  -.7099E+00  -.4991E+01  0.1174E+01  -.1097E+01  0.1249E-02
4  0.1209E+01  -.5569E+02  0.1074E+02  -.3284E+03  0.1443E+02  0.2471E+02
5  0.5390E+02  -.1196E+01  -.1069E+02  0.1435E+02  -.3412E+03  0.2636E+02
6  -.9279E+01  0.9211E+01  -.4371E-02  0.3300E+01  0.3682E+01  -.4182E+03
-----
```

```
***** Total Fairlead Line Tensions *****
(m.ton)
:
:
: Offset Type: Specified Force; Continuous Static Equilibrium :
:
: Global-Relative Force Direction: (Gx,Gy,Gz) = ( 1.00, 1.00, 1.00) :
:
: Force Application Point (Vx,Vy,Vz) = ( .00, .00, .00) :
:
:
*****
```

Line #:	1	2	3	4	5	6
Offset Number						
1.00	15.60	15.60	15.60	15.60	15.60	15.60
2.00	15.42	15.35	15.54	15.79	15.86	15.68
3.00	15.23	15.14	15.47	16.00	16.15	15.76
4.00	15.08	14.94	15.40	16.24	16.46	15.84
5.00	14.93	14.74	15.33	16.47	16.77	15.92
6.00	14.78	14.54	15.26	16.71	17.08	16.00
7.00	14.63	14.33	15.21	16.95	17.40	16.08
8.00	14.48	14.13	15.16	17.19	17.72	16.17
9.00	14.34	13.93	15.11	17.42	18.04	16.26
10.00	14.19	13.73	15.05	17.66	18.37	16.35
11.00	14.05	13.55	15.02	17.88	18.75	16.42
12.00	13.92	13.38	14.98	18.09	19.16	16.49
13.00	13.79	13.21	14.95	18.31	19.58	16.55
14.00	13.67	13.05	14.91	18.53	19.98	16.62
15.00	13.55	12.90	14.86	18.81	20.38	16.71

***** IX. Continuous Equilibrium Under Specified Torquing *****

```

:-----:
:      :
: Offset Type: Specified Torque; Continuous Static Equilibrium :
:      :
: Global-Relative Moment Axis (Gx,Gy,Gz) = ( 1.00, 1.00, 1.00) :
:      :
:-----:

```

Moments reported about Vessel coordinate
(Vx,Vy,Vz) = (0.000E-01, 0.000E-01, 0.000E-01)

>>> Table Notes:

For "continuous offset" sequences, the "Total Restoring Moment" is defined as the component of *Net* mooring moment along the applied torque vector and will therefore point in the same direction from one offset row to the next in a sequence.

---- Most Exposed Line Characteristics ----

Offset Number	Line #	-- Fairlead Tensions --			Unstretched Suspended Length (m.)	Anchor Forces		Total Restoring Moment (m.ton*m.)
		Total (m.ton)	Horiz. (m.ton)	Vert. (m.ton)		Rel. to Bottom <Parallel> (m.ton)	<Perp.> (m.ton)	
1.0	1	15.60	9.02	-12.77	60.9	9.02	- .00	1.216E-05
2.0	3	15.92	9.24	-13.02	62.0	9.24	- .00	-4.689E+01
3.0	3	16.58	9.80	-13.46	63.9	9.80	- .00	-9.472E+01
4.0	3	17.47	10.59	-13.98	66.4	10.59	- .00	-1.440E+02
5.0	3	18.49	11.51	-14.50	69.2	11.51	- .00	-1.950E+02
6.0	3	19.81	12.74	-15.23	72.5	12.74	- .00	-2.485E+02
7.0	3	21.26	14.09	-16.02	76.0	14.09	- .00	-3.044E+02
8.0	3	22.72	15.46	-16.70	79.6	15.46	- .00	-3.620E+02
9.0	3	24.33	16.99	-17.45	83.3	16.99	- .00	-4.220E+02
10.0	3	26.18	18.76	-18.39	87.2	18.76	- .00	-4.850E+02
11.0	3	28.03	20.54	-19.20	91.1	20.54	- .00	-5.498E+02
12.0	4	29.93	22.77	-19.43	93.0	22.77	- .00	-6.166E+02
13.0	4	32.35	25.16	-20.47	97.1	25.16	- .00	-6.859E+02
14.0	4	34.81	27.59	-21.38	101.4	27.59	- .00	-7.572E+02
15.0	4	37.37	30.12	-22.16	105.8	30.12	- .00	-8.303E+02

***** IX. Continuous Equilibrium Under Specified Torquing *****

```

:-----:
:      :
: Offset Type: Specified Torque; Continuous Static Equilibrium :
:      :
: Global-Relative Moment Axis (Gx,Gy,Gz) = ( 1.00, 1.00, 1.00) :
:      :
:-----:

```

Moments reported about Vessel coordinate
(Vx,Vy,Vz) = (0.000E-01, 0.000E-01, 0.000E-01)

----- Summary of Continuous Equilibrium Offsets -----

Offset Number	Force (m.ton)	Moment (ton-meter)	---- C.G. Offset ---- (m.)			--- Angular Offset --- (deg)		
			Gx	Gy	Gz	Pitch	Roll	Yaw
1	0.00E-01	0.00E-01	.000	.000	.000	-.00	.00	.00
2	0.00E-01	1.00E+02	-.037	.076	-.006	2.74	2.90	8.33
3	0.00E-01	2.00E+02	-.035	.184	-.021	5.29	5.90	16.10
4	0.00E-01	3.00E+02	-.001	.311	-.039	7.63	8.93	23.04
5	0.00E-01	4.00E+02	.059	.450	-.058	9.82	11.98	29.22
6	0.00E-01	5.00E+02	.131	.590	-.083	11.80	14.95	34.47
7	0.00E-01	6.00E+02	.217	.725	-.113	13.60	17.81	38.80
8	0.00E-01	7.00E+02	.310	.856	-.141	15.30	20.62	42.70
9	0.00E-01	8.00E+02	.404	.980	-.169	16.85	23.35	46.12
10	0.00E-01	9.00E+02	.500	1.088	-.202	18.17	25.89	48.87
11	0.00E-01	1.00E+03	.600	1.194	-.231	19.41	28.40	51.45
12	0.00E-01	1.10E+03	.702	1.307	-.257	20.58	30.85	53.82
13	0.00E-01	1.20E+03	.791	1.385	-.294	21.49	33.05	55.48
14	0.00E-01	1.30E+03	.882	1.466	-.328	22.33	35.17	57.02
15	0.00E-01	1.40E+03	.973	1.544	-.358	23.12	37.26	58.46

***** IX. Continuous Equilibrium Under Specified Torquing *****

```

:-----:
:      :
: Offset Type: Specified Torque; Continuous Static Equilibrium :
:      :
: Global-Relative Moment Axis (Gx,Gy,Gz) = ( 1.00, 1.00, 1.00) :
:      :
:-----:

```

Moments reported about Vessel coordinate
(Vx,Vy,Vz) = (0.000E-01, 0.000E-01, 0.000E-01)

+++++
Total Restoring Characteristics
and Cross-Coupling Summary
+++++

Offset Number	Total Restoring Moment (m.ton*m.)	---- Induced Moments ----			Vessel-Relative Forces		
		Roll -----	Pitch (m.ton*m.)	Yaw -----	Surge -----	Sway (m.ton)	Heave -----
1.0	1.216E-05	0.00E-01	0.00E-01	2.11E-05	0.0	0.0	-76.6
2.0	-4.689E+01	-1.06E+01	-1.28E+01	-5.77E+01	3.7	-3.9	-77.1
3.0	-9.472E+01	-1.95E+01	-2.83E+01	-1.15E+02	7.3	-8.1	-78.2
4.0	-1.440E+02	-2.70E+01	-4.67E+01	-1.73E+02	10.8	-12.6	-79.5
5.0	-1.950E+02	-3.30E+01	-6.80E+01	-2.31E+02	14.2	-17.3	-80.3
6.0	-2.485E+02	-3.83E+01	-9.28E+01	-2.89E+02	17.6	-22.2	-81.4
7.0	-3.044E+02	-4.28E+01	-1.21E+02	-3.46E+02	21.1	-27.5	-82.8
8.0	-3.620E+02	-4.54E+01	-1.51E+02	-4.04E+02	24.5	-32.7	-83.5
9.0	-4.220E+02	-4.71E+01	-1.84E+02	-4.62E+02	27.9	-38.1	-83.8
10.0	-4.850E+02	-4.98E+01	-2.21E+02	-5.20E+02	31.2	-43.7	-84.5
11.0	-5.498E+02	-5.08E+01	-2.61E+02	-5.77E+02	34.4	-49.2	-84.3
12.0	-6.166E+02	-4.98E+01	-3.03E+02	-6.35E+02	37.4	-54.6	-83.4
13.0	-6.859E+02	-5.15E+01	-3.48E+02	-6.93E+02	40.6	-60.4	-83.5
14.0	-7.572E+02	-5.19E+01	-3.95E+02	-7.50E+02	43.6	-66.1	-83.0
15.0	-8.303E+02	-5.02E+01	-4.44E+02	-8.08E+02	46.4	-71.5	-81.8

***** IX. Continuous Equilibrium Under Specified Torquing *****

```

:-----:
:      :
: Offset Type: Specified Torque; Continuous Static Equilibrium :
:      :
: Global-Relative Moment Axis (Gx,Gy,Gz) = ( 1.00, 1.00, 1.00) :
:      :
:-----:

```

Moments reported about Vessel coordinate
(Vx,Vy,Vz) = (0.000E-01, 0.000E-01, 0.000E-01)

Offset Number	<--- Vessel-Relative Forces --->			<--- Vessel-Relative Moments --->		
	Fvx -----	Fvy (m.ton)	Fvz -----	Mvx -----	Mvy (m.ton*m.)	Mvz -----
1.0	0.1431E-05	0.2384E-05	-.7661E+02	0.0000E+00	0.0000E+00	0.2107E-04
2.0	0.3698E+01	-.3914E+01	-.7710E+02	-.1059E+02	-.1279E+02	-.5773E+02
3.0	0.7276E+01	-.8118E+01	-.7824E+02	-.1953E+02	-.2828E+02	-.1155E+03
4.0	0.1078E+02	-.1260E+02	-.7945E+02	-.2703E+02	-.4669E+02	-.1732E+03
5.0	0.1422E+02	-.1730E+02	-.8031E+02	-.3300E+02	-.6803E+02	-.2309E+03
6.0	0.1763E+02	-.2224E+02	-.8139E+02	-.3830E+02	-.9277E+02	-.2887E+03
7.0	0.2111E+02	-.2745E+02	-.8280E+02	-.4278E+02	-.1206E+03	-.3464E+03
8.0	0.2453E+02	-.3275E+02	-.8349E+02	-.4537E+02	-.1510E+03	-.4042E+03
9.0	0.2788E+02	-.3812E+02	-.8380E+02	-.4711E+02	-.1845E+03	-.4619E+03
10.0	0.3121E+02	-.4371E+02	-.8446E+02	-.4983E+02	-.2214E+03	-.5196E+03
11.0	0.3438E+02	-.4920E+02	-.8425E+02	-.5078E+02	-.2608E+03	-.5773E+03
12.0	0.3741E+02	-.5458E+02	-.8338E+02	-.4985E+02	-.3025E+03	-.6351E+03
13.0	0.4057E+02	-.6040E+02	-.8350E+02	-.5148E+02	-.3476E+03	-.6925E+03
14.0	0.4358E+02	-.6606E+02	-.8300E+02	-.5189E+02	-.3945E+03	-.7503E+03
15.0	0.4639E+02	-.7153E+02	-.8177E+02	-.5016E+02	-.4436E+03	-.8081E+03

***** IX. Continuous Equilibrium Under Specified Torquing *****

```

:-----:
:         |         |         |         |         |         |
:         |         |         |         |         |         |
: Offset Type: Specified Torque; Continuous Static Equilibrium :
:         |         |         |         |         |         |
: Global-Relative Moment Axis (Gx,Gy,Gz) = ( 1.00, 1.00, 1.00) :
:         |         |         |         |         |         |
:-----:

```

Moments reported about Vessel coordinate
(Vx,Vy,Vz) = (0.000E-01, 0.000E-01, 0.000E-01)

>>> Raw Mooring Stiffness matrix in vessel-bound system (Vx, Vy, Vz)

dFx/dx	dFy/dx	dFz/dx	dMx/dx	dMy/dx	dMz/dx
dFx/dy	dFy/dy	dFz/dy	dMx/dy	dMy/dy	dMz/dy
dFx/dz	dFy/dz	dFz/dz	dMx/dz	dMy/dz	dMz/dz
dFx/dPx	dFy/dPx	dFz/dPx	dMx/dPx	dMy/dPx	dMz/dPx
dFx/dPy	dFy/dPy	dFz/dPy	dMx/dPy	dMy/dPy	dMz/dPy
dFx/dPz	dFy/dPz	dFz/dPz	dMx/dPz	dMy/dPz	dMz/dPz

Column => 1 2 3 4 5 6

Row	Offset Number = 1					
v						
1	-.6602E+01	-.7153E-05	0.0000E+00	0.0000E+00	-.2896E+02	0.8158E-05
2	-.2384E-05	-.6602E+01	0.0000E+00	0.2893E+02	-.3815E-04	-.1276E-03
3	-.4768E-05	0.0000E+00	-.5734E+01	0.0000E+00	-.3815E-04	0.1838E-04
4	0.0000E+00	-.5249E+02	-.2186E-02	-.3398E+03	0.0000E+00	-.5421E-03
5	0.5241E+02	0.0000E+00	0.0000E+00	0.0000E+00	-.3404E+03	0.0000E+00
6	-.4098E-03	-.6830E-03	0.0000E+00	0.0000E+00	-.2186E-02	-.3933E+03

Column => 1 2 3 4 5 6

Row	Offset Number = 2					
v						
1	-.6614E+01	0.7317E-02	0.1681E+00	0.4180E+01	-.2761E+02	0.2040E+01
2	0.7293E-02	-.6605E+01	-.1802E+00	0.2753E+02	0.3942E+01	0.6766E+00
3	-.2462E-01	0.7754E-01	-.5566E+01	-.1396E+01	-.1838E+01	-.6983E+01
4	0.3566E+01	-.5348E+02	0.1676E+01	-.3370E+03	-.2842E+02	0.7605E+01
5	0.5348E+02	0.3378E+01	0.1032E+01	0.2933E+02	-.3372E+03	-.9058E+01
6	-.1189E+01	-.2477E+01	-.8183E+01	-.7173E+01	0.6407E+01	-.4110E+03

Column => 1 2 3 4 5 6

Row	Offset Number = 3					
v						
1	-.6643E+01	0.3385E-01	0.2466E+00	0.7363E+01	-.2426E+02	0.4689E+01
2	0.4107E-01	-.6656E+01	-.3193E+00	0.2425E+02	0.6668E+01	-.2359E+00
3	-.4909E-01	0.8417E-01	-.5144E+01	-.2218E+01	-.3775E+01	-.1284E+02
4	0.6706E+01	-.5607E+02	0.4190E+01	-.3291E+03	-.5582E+02	0.1748E+02
5	0.5612E+02	0.6124E+01	0.1993E+01	0.5888E+02	-.3291E+03	-.2002E+02
6	-.1856E+01	-.6241E+01	-.1405E+02	-.1385E+02	0.9715E+01	-.4556E+03

Column => 1 2 3 4 5 6

Row	Offset Number = 4					
v						
1	-.6672E+01	0.6089E-01	0.2238E+00	0.9175E+01	-.1997E+02	0.7223E+01
2	0.7085E-01	-.6715E+01	-.3436E+00	0.2001E+02	0.7756E+01	-.2346E+01
3	-.1438E+00	0.1554E+00	-.4618E+01	-.2494E+01	-.5498E+01	-.1714E+02
4	0.9128E+01	-.5935E+02	0.7510E+01	-.3186E+03	-.8236E+02	0.3102E+02
5	0.5950E+02	0.7983E+01	0.3075E+01	0.8857E+02	-.3181E+03	-.3387E+02
6	-.2798E+01	-.1084E+02	-.1695E+02	-.1924E+02	0.8355E+01	-.5135E+03

Column => 1 2 3 4 5 6

Row	Offset Number = 5					
v						
1	-.7256E+01	0.2200E+00	-.7336E+00	0.1037E+02	-.2196E+02	0.8080E+01
2	0.1917E+00	-.7556E+01	0.1224E+01	0.2207E+02	0.1436E+02	-.1043E+01
3	-.6833E+00	0.9968E+00	-.5735E+01	-.7188E+01	-.1580E+02	-.2386E+02
4	0.1156E+02	-.6010E+02	0.6282E+01	-.3386E+03	-.1269E+03	0.3708E+02
5	0.6048E+02	0.1232E+02	-.4647E+01	0.1011E+03	-.3617E+03	-.7106E+02
6	-.5209E+01	-.1214E+02	-.2473E+02	-.4984E+02	-.3542E+02	-.5961E+03

Column => 1 2 3 4 5 6

Row	Offset Number = 6					
v						
1	-.7546E+01	-.2084E+00	-.1141E+01	0.1402E+02	-.1828E+02	0.8950E+01
2	-.1531E+00	-.7834E+01	0.8431E+00	0.1964E+02	0.1114E+02	-.4120E+01
3	-.1009E+01	0.9695E+00	-.5521E+01	-.4101E+01	-.1734E+02	-.2662E+02
4	0.1546E+02	-.6169E+02	0.1425E+02	-.3490E+03	-.1375E+03	0.6928E+02
5	0.6361E+02	0.1154E+02	-.4533E+01	0.1455E+03	-.3559E+03	-.9849E+02
6	-.8887E+01	-.1850E+02	-.2684E+02	-.3102E+02	-.5844E+02	-.6651E+03

Column => 1 2 3 4 5 6

Row	Offset Number = 7					
v						
1	-.8251E+01	-.3030E+00	-.2486E+01	0.1588E+02	-.2243E+02	0.7496E+01
2	-.5360E-01	-.8148E+01	0.1555E+01	0.1678E+02	0.1409E+02	-.5712E+01
3	-.1803E+01	0.1320E+01	-.6430E+01	-.1860E+01	-.2616E+02	-.3017E+02
4	0.1646E+02	-.6531E+02	0.1844E+02	-.3384E+03	-.1579E+03	0.9989E+02
5	0.6286E+02	0.1429E+02	-.1273E+02	0.1749E+03	-.4192E+03	-.1365E+03
6	-.1374E+02	-.2059E+02	-.3000E+02	-.3253E+02	-.1112E+03	-.7287E+03

Column => 1 2 3 4 5 6

Row	Offset Number = 8					
v						
1	-.9463E+01	-.8282E+00	-.1322E+01	0.2279E+02	-.1823E+02	0.1571E+02
2	-.9287E+00	-.1055E+02	0.2307E+01	0.2629E+02	0.1830E+02	-.6684E+01
3	-.1241E+01	0.2142E+01	-.7690E+01	-.8443E+01	-.3014E+02	-.3976E+02
4	0.2223E+02	-.6502E+02	0.1497E+02	-.3839E+03	-.1998E+03	0.9976E+02
5	0.6819E+02	0.1753E+02	-.1225E+02	0.1860E+03	-.4233E+03	-.1708E+03
6	-.5054E+01	-.2654E+02	-.4255E+02	-.9156E+02	-.1192E+03	-.8943E+03

```
-----
Column => 1          2          3          4          5          6
-----
Row
|
v
Offset Number = 9
1  -.1001E+02  -.7823E+00  -.9252E+00  0.2248E+02  -.1446E+02  0.2007E+02
2  -.9307E+00  -.1058E+02  0.2305E+01  0.2048E+02  0.1497E+02  -.1103E+02
3  -.1413E+01  0.2484E+01  -.7129E+01  -.6504E+01  -.2892E+02  -.3984E+02
4  0.2230E+02  -.6984E+02  0.2010E+02  -.3706E+03  -.2191E+03  0.1421E+03
5  0.7289E+02  0.1748E+02  -.8417E+01  0.2204E+03  -.4066E+03  -.1977E+03
6  -.7389E+01  -.3029E+02  -.3691E+02  -.8803E+02  -.1317E+03  -.9502E+03
-----
```

```
-----
Column => 1          2          3          4          5          6
-----
Row
|
v
Offset Number = 10
1  -.1153E+02  -.2793E+00  -.2688E+01  0.2487E+02  -.2358E+02  0.2189E+02
2  -.2427E+00  -.1187E+02  0.3122E+01  0.1827E+02  0.2089E+02  -.1794E+02
3  -.2779E+01  0.3328E+01  -.9463E+01  -.2002E+01  -.4614E+02  -.4333E+02
4  0.2335E+02  -.7300E+02  0.2647E+02  -.3716E+03  -.2303E+03  0.1920E+03
5  0.7291E+02  0.1994E+02  -.2235E+02  0.2533E+03  -.5114E+03  -.2647E+03
6  -.7988E+01  -.3964E+02  -.4469E+02  -.7167E+02  -.2014E+03  -.1067E+04
-----
```

```
-----
Column => 1          2          3          4          5          6
-----
Row
|
v
Offset Number = 11
1  -.1275E+02  -.1494E+01  -.2104E+01  0.3405E+02  -.1624E+02  0.2715E+02
2  -.1775E+01  -.1269E+02  0.4416E+01  0.2554E+02  0.2005E+02  -.1208E+02
3  -.2400E+01  0.4153E+01  -.1093E+02  -.5566E+01  -.5047E+02  -.5200E+02
4  0.3177E+02  -.7106E+02  0.2687E+02  -.4421E+03  -.2634E+03  0.2051E+03
5  0.7959E+02  0.2016E+02  -.2560E+02  0.2754E+03  -.5238E+03  -.3302E+03
6  -.5596E+01  -.3875E+02  -.5408E+02  -.1180E+03  -.2745E+03  -.1194E+04
-----
```

```
-----
Column => 1          2          3          4          5          6
-----
Row
|
v
Offset Number = 12
1  -.1310E+02  -.1563E+01  -.3516E+01  0.3145E+02  -.2179E+02  0.2300E+02
2  -.1746E+01  -.1402E+02  0.6112E+01  0.2256E+02  0.2992E+02  -.1542E+02
3  -.3318E+01  0.5602E+01  -.1416E+02  -.2942E+01  -.7318E+02  -.5770E+02
4  0.3109E+02  -.7710E+02  0.3211E+02  -.4335E+03  -.2801E+03  0.2656E+03
5  0.7955E+02  0.2645E+02  -.4582E+02  0.3145E+03  -.6919E+03  -.4100E+03
6  -.1161E+02  -.3715E+02  -.5987E+02  -.1081E+03  -.3852E+03  -.1257E+04
-----
```

```
-----
Column => 1          2          3          4          5          6
-----
Row
|
v
Offset Number = 13
1  -.1318E+02  -.2530E+01  -.3382E+01  0.3002E+02  -.1653E+02  0.1949E+02
2  -.2294E+01  -.1526E+02  0.5743E+01  0.2098E+02  0.2576E+02  -.2414E+02
3  -.3360E+01  0.6199E+01  -.1387E+02  -.1153E+01  -.7026E+02  -.5619E+02
4  0.3022E+02  -.8276E+02  0.3632E+02  -.4288E+03  -.2920E+03  0.3200E+03
5  0.8446E+02  0.2590E+02  -.4083E+02  0.3459E+03  -.6741E+03  -.4393E+03
6  -.1720E+02  -.5408E+02  -.5584E+02  -.8014E+02  -.3765E+03  -.1350E+04
-----
```

```
-----
Column => 1          2          3          4          5          6
-----
Row
|
v
Offset Number = 14
1  -.1317E+02  -.2822E+01  -.3089E+01  0.2741E+02  -.1253E+02  0.1879E+02
2  -.2645E+01  -.1491E+02  0.5828E+01  0.1728E+02  0.2055E+02  -.2563E+02
3  -.3420E+01  0.6665E+01  -.1368E+02  0.6605E+00  -.6720E+02  -.5552E+02
4  0.2934E+02  -.8709E+02  0.4058E+02  -.4265E+03  -.3042E+03  0.3774E+03
5  0.8862E+02  0.2621E+02  -.3573E+02  0.3772E+03  -.6563E+03  -.4638E+03
6  -.2104E+02  -.5518E+02  -.4794E+02  -.7678E+02  -.3819E+03  -.1367E+04
-----
```

```
-----
Column => 1          2          3          4          5          6
-----
Row
|
v
Offset Number = 15
1  -.1558E+02  -.3843E+01  -.2700E+01  0.3873E+02  -.1365E+02  0.2989E+02
2  -.4196E+01  -.1580E+02  0.1006E+02  0.2311E+02  0.4018E+02  -.1027E+02
3  -.2596E+01  0.9117E+01  -.2075E+02  -.5969E+01  -.1093E+03  -.7800E+02
4  0.3834E+02  -.8911E+02  0.3456E+02  -.4856E+03  -.3543E+03  0.3741E+03
5  0.9612E+02  0.3930E+02  -.7447E+02  0.3780E+03  -.9347E+03  -.6066E+03
6  -.9101E+01  -.4383E+02  -.7672E+02  -.1774E+03  -.5871E+03  -.1552E+04
-----
```

***** Total Fairlead Line Tensions *****
 (m.ton)

```

:-----:
::
:: Offset Type: Specified Torque; Continuous Static Equilibrium ::
::
:: Global-Relative Moment Axis (Gx,Gy,Gz) = ( 1.00, 1.00, 1.00) ::
::
:-----:

```

Line #:	1	2	3	4	5	6
Offset Number						
1.00	15.60	15.60	15.60	15.60	15.60	15.60
2.00	15.72	15.80	15.92	15.87	15.74	15.71
3.00	16.17	16.29	16.58	16.46	16.15	16.16
4.00	16.85	16.95	17.47	17.27	16.73	16.84
5.00	17.68	17.72	18.49	18.23	17.41	17.67
6.00	18.75	18.49	19.81	19.42	18.08	18.81
7.00	20.05	19.41	21.26	20.85	18.89	20.10
8.00	21.40	20.42	22.72	22.31	19.79	21.40
9.00	22.85	21.38	24.33	23.90	20.62	22.90
10.00	24.68	22.17	26.18	25.83	21.29	24.63
11.00	26.57	22.96	28.03	27.82	21.96	26.38
12.00	28.50	23.85	29.84	29.93	22.66	28.17
13.00	30.76	24.66	31.93	32.35	23.29	30.25
14.00	33.12	25.43	34.11	34.81	23.93	32.37
15.00	35.58	26.22	36.30	37.37	24.59	34.51

Appendix Z

Sample Problem Output

This appendix contains output generated by Catsim as a result of a simulation execution using input data presented in Appendix B for the composite buoy-hawser-tanker case.

SeaSoft Systems Simulation Library

Volume 8

Catenary-Elastic Mooring Statics Calculator

 Catsim Version 5.11

Copyright (C) 2005
 By SeaSoft Systems

Sample Problem: Catsim support of CALM installation
 Buoy-Hawser-Tanker configuration

Executed at 11:02 on 4/5/05

**
 ***** I. Line Characteristics Summary *****
 **

>>> Interpolation level 1 for line type A of 2 type(s)
 Vertical distance to nominal fairlead 7.15 m.
 Vertical separation between endpoints 24.35 m.

- Segment - Type	Length (m.)	Nominal Diameter (mm)	Submerged Weight (kgw/m.)	---- Elastic Coefficients ----		
				Alpha 1 (m.ton** ⁻¹)	Alpha 2 (m.ton** ⁻²)	Alpha 3 (m.ton** ⁻³)
1 Chain	457.00	102.00	208.83	0.120E-04	0.000E+00	0.000E+00

Table Index	Top Tension (m.ton)	Anchor Tension (m.ton)	Horizontal Tension (m.ton)	-- Line angle --		Endpoint Separation (m.)	Bottom Length (m.)
				Top (deg)	Anchor ---		
1	5.08	.00	.00	90.0	.0	432.65	432.65
2	5.18	.10	.10	88.9	.0	434.40	432.18
3	5.22	.14	.14	88.5	.0	434.85	432.00
4	5.27	.19	.19	87.9	.0	435.40	431.76
5	5.34	.26	.26	87.2	.0	436.07	431.44
6	5.44	.36	.36	86.2	.0	436.85	431.00
7	5.58	.49	.49	84.9	.0	437.75	430.40
8	5.76	.68	.68	83.3	.0	438.78	429.61
9	6.02	.93	.93	81.1	.0	439.93	428.55
10	6.36	1.28	1.28	78.4	.0	441.17	427.15
11	6.84	1.76	1.76	75.1	.0	442.48	425.33
12	7.51	2.42	2.42	71.2	.0	443.83	422.99
13	8.41	3.33	3.33	66.7	.0	445.18	420.02
14	9.66	4.58	4.58	61.7	.0	446.50	416.27
15	11.38	6.30	6.30	56.4	.0	447.76	411.63
16	13.74	8.66	8.66	50.9	.0	448.93	405.93
17	16.99	11.91	11.91	45.5	.0	450.00	399.01
18	21.46	16.38	16.38	40.3	.0	450.97	390.66
19	27.61	22.53	22.53	35.3	.0	451.85	380.65
20	36.06	30.98	30.98	30.8	.0	452.63	368.74
21	47.69	42.61	42.61	26.7	.0	453.34	354.60
22	63.68	58.60	58.60	23.0	.0	453.99	337.88
23	85.67	80.59	80.59	19.8	.0	454.59	318.14
24	115.92	110.84	110.84	17.0	.0	455.17	294.90
25	157.51	152.44	152.44	14.6	.0	455.76	267.56
26	214.72	209.64	209.64	12.5	.0	456.38	235.44
27	293.39	288.32	288.32	10.7	.0	457.07	197.70
28	401.59	396.53	396.53	9.1	.0	457.89	153.40
29	550.39	545.34	545.34	7.8	.0	458.90	101.40
30	755.04	750.00	750.00	6.6	.0	460.19	40.33

**
 ***** I. Line Characteristics Summary *****
 **

>>> Interpolation level 1 for line type B of 2 type(s)
 Vertical distance to nominal fairlead 7.15 m.
 Vertical separation between endpoints -12.25 m.

Segment Type	Length (m.)	Nominal Diameter (mm)	Submerged Weight (kgw/m.)	Elastic Coefficients		
				Alpha 1 (m.ton**-1)	Alpha 2 (m.ton**-2)	Alpha 3 (m.ton**-3)
1 Nylon	50.00	240.00	38.59	0.834E-03	-0.618E-06	0.168E-09
2 Chain	2.00	102.00	240.33	0.120E-04	0.000E+00	0.000E+00

Table Index	Buoy Tension (m.ton)	Tanker Tension (m.ton)	Horizontal Tension (m.ton)	Line angle Buoy (deg)	Line angle Tanker (deg)	Endpoint Separation (m.)	Bottom Length (m.)
1	.41	2.00	.00	90.0	-90.0	.00	.00
2	.77	1.65	.10	82.6	-86.5	15.39	.00
3	.78	1.65	.14	79.8	-85.2	18.91	.00
4	.79	1.66	.19	76.1	-83.4	22.93	.00
5	.80	1.67	.26	71.1	-81.0	27.35	.00
6	.83	1.70	.36	64.6	-77.8	31.98	.00
7	.89	1.74	.49	56.4	-73.6	36.54	.00
8	.99	1.82	.68	46.7	-68.2	40.67	.00
9	1.15	1.97	.93	36.1	-61.7	44.07	.00
10	1.42	2.20	1.28	25.7	-54.5	46.58	.00
11	1.84	2.58	1.76	16.5	-47.0	48.27	.00
12	2.45	3.16	2.42	8.8	-40.0	49.32	.00
13	3.33	4.01	3.33	2.9	-33.9	49.96	.00
14	4.58	5.23	4.58	-1.5	-28.9	50.35	.00
15	6.32	6.95	6.30	-4.8	-25.0	50.60	.00
16	8.73	9.34	8.66	-7.2	-22.0	50.80	.00
17	12.05	12.65	11.91	-8.9	-19.7	51.00	.00
18	16.64	17.22	16.38	-10.1	-18.0	51.22	.00
19	22.94	23.52	22.53	-10.9	-16.7	51.50	.00
20	31.62	32.19	30.98	-11.5	-15.7	51.86	.00
21	43.54	44.10	42.61	-11.9	-14.9	52.35	.00
22	59.93	60.48	58.60	-12.1	-14.3	53.00	.00
23	82.43	82.97	80.59	-12.1	-13.8	53.87	.00
24	113.34	113.87	110.84	-12.1	-13.2	55.00	.00
25	155.77	156.28	152.44	-11.9	-12.7	56.48	.00
26	214.01	214.51	209.64	-11.6	-12.2	58.33	.00
27	293.96	294.44	288.32	-11.2	-11.7	60.59	.00
28	403.72	404.18	396.53	-10.8	-11.2	63.19	.00
29	554.49	554.93	545.34	-10.4	-10.7	65.94	.00
30	761.73	762.16	750.00	-10.1	-10.2	68.48	.00

**
 ***** I. Line Characteristics Summary *****
 **

>>> Interpolation level 2 for line type A of 2 type(s)
 Vertical distance to nominal fairlead 4.77 m.
 Vertical separation between endpoints 26.73 m.

Segment Type	Length (m.)	Nominal Diameter (mm)	Submerged Weight (kgw/m.)	Elastic Coefficients		
				Alpha 1 (m.ton**-1)	Alpha 2 (m.ton**-2)	Alpha 3 (m.ton**-3)
1 Chain	457.00	102.00	208.83	0.120E-04	0.000E+00	0.000E+00

Table Index	Top Tension (m.ton)	Anchor Tension (m.ton)	Horizontal Tension (m.ton)	Line angle Top (deg)	Line angle Anchor (deg)	Endpoint Separation (m.)	Bottom Length (m.)
1	5.58	.00	.00	90.0	.0	430.27	430.27
2	5.68	.10	.10	89.0	.0	432.06	429.79
3	5.72	.14	.14	88.6	.0	432.53	429.62
4	5.77	.19	.19	88.1	.0	433.10	429.38
5	5.84	.26	.26	87.4	.0	433.79	429.05
6	5.94	.36	.36	86.5	.0	434.61	428.61
7	6.07	.49	.49	85.4	.0	435.56	428.01
8	6.26	.68	.68	83.8	.0	436.65	427.21
9	6.51	.93	.93	81.8	.0	437.87	426.14
10	6.86	1.28	1.28	79.3	.0	439.21	424.72
11	7.34	1.76	1.76	76.1	.0	440.63	422.87
12	8.00	2.42	2.42	72.4	.0	442.11	420.48
13	8.91	3.33	3.33	68.1	.0	443.59	417.43
14	10.16	4.58	4.58	63.2	.0	445.06	413.59
15	11.88	6.30	6.30	58.0	.0	446.46	408.80
16	14.24	8.66	8.66	52.5	.0	447.77	402.90
17	17.49	11.91	11.91	47.1	.0	448.98	395.71
18	21.96	16.38	16.38	41.8	.0	450.08	387.03
19	28.11	22.53	22.53	36.7	.0	451.07	376.60
20	36.56	30.98	30.98	32.1	.0	451.96	364.17
21	48.19	42.61	42.61	27.8	.0	452.76	349.40
22	64.18	58.60	58.60	24.1	.0	453.49	331.91
23	86.17	80.59	80.59	20.7	.0	454.16	311.27
24	116.41	110.84	110.84	17.8	.0	454.81	286.94
25	158.01	152.44	152.44	15.3	.0	455.45	258.31
26	215.21	209.64	209.64	13.1	.0	456.11	224.65
27	293.88	288.32	288.32	11.2	.0	456.84	185.12
28	402.08	396.53	396.53	9.5	.0	457.70	138.69
29	550.88	545.34	545.34	8.1	.0	458.73	84.17
30	755.53	750.00	750.00	6.9	.0	460.05	20.15

**
 ***** I. Line Characteristics Summary *****
 **

>>> Interpolation level 2 for line type B of 2 type(s)
 Vertical distance to nominal fairlead 4.77 m.
 Vertical separation between endpoints -9.87 m.

Segment Type	Length (m.)	Nominal Diameter (mm)	Submerged Weight (kgw/m.)	Elastic Coefficients		
				Alpha 1 (m.ton**-1)	Alpha 2 (m.ton**-2)	Alpha 3 (m.ton**-3)
1 Nylon	50.00	240.00	38.59	0.834E-03	-0.618E-06	0.168E-09
2 Chain	2.00	102.00	240.33	0.120E-04	0.000E+00	0.000E+00

Table Index	Buoy Tension (m.ton)	Tanker Tension (m.ton)	Horizontal Tension (m.ton)	-- Line angle -- Buoy (deg) Tanker (deg)	Endpoint Separation (m.)	Bottom Length (m.)
1	.46	1.95	.00	90.0 -90.0	.00	.00
2	.82	1.60	.10	83.0 -86.4	15.44	.00
3	.82	1.60	.14	80.4 -85.1	18.98	.00
4	.83	1.61	.19	76.9 -83.3	23.03	.00
5	.85	1.62	.26	72.1 -80.8	27.48	.00
6	.88	1.65	.36	65.9 -77.5	32.16	.00
7	.93	1.69	.49	58.1 -73.1	36.77	.00
8	1.03	1.77	.68	48.8 -67.5	40.96	.00
9	1.19	1.91	.93	38.6 -60.8	44.42	.00
10	1.46	2.14	1.28	28.5 -53.3	46.98	.00
11	1.87	2.51	1.76	19.4 -45.5	48.72	.00
12	2.47	3.08	2.42	11.8 -38.2	49.80	.00
13	3.35	3.92	3.33	5.8 -31.9	50.45	.00
14	4.58	5.12	4.58	1.4 -26.7	50.85	.00
15	6.30	6.82	6.30	-2.0 -22.6	51.11	.00
16	8.69	9.19	8.66	-4.4 -19.5	51.31	.00
17	11.98	12.47	11.91	-6.1 -17.2	51.50	.00
18	16.52	16.99	16.38	-7.4 -15.5	51.72	.00
19	22.76	23.23	22.53	-8.3 -14.1	52.00	.00
20	31.36	31.82	30.98	-8.9 -13.2	52.35	.00
21	43.17	43.63	42.61	-9.3 -12.4	52.83	.00
22	59.42	59.86	58.60	-9.5 -11.8	53.47	.00
23	81.74	82.17	80.59	-9.6 -11.3	54.33	.00
24	112.41	112.83	110.84	-9.6 -10.8	55.45	.00
25	154.54	154.96	152.44	-9.5 -10.3	56.90	.00
26	212.42	212.82	209.64	-9.3 -9.9	58.73	.00
27	291.91	292.30	288.32	-9.0 -9.5	60.97	.00
28	401.12	401.50	396.53	-8.7 -9.0	63.55	.00
29	551.20	551.56	545.34	-8.4 -8.6	66.29	.00
30	757.53	757.87	750.00	-8.1 -8.3	68.82	.00

**
 ***** I. Line Characteristics Summary *****
 **

>>> Interpolation level 3 for line type A of 2 type(s)
 Vertical distance to nominal fairlead 2.38 m.
 Vertical separation between endpoints 29.12 m.

Segment Type	Length (m.)	Nominal Diameter (mm)	Submerged Weight (kgw/m.)	Elastic Coefficients		
				Alpha 1 (m.ton**-1)	Alpha 2 (m.ton**-2)	Alpha 3 (m.ton**-3)
1 Chain	457.00	102.00	208.83	0.120E-04	0.000E+00	0.000E+00

Table Index	Top Tension (m.ton)	Anchor Tension (m.ton)	Horizontal Tension (m.ton)	-- Line angle -- Top (deg) Anchor (deg)	Endpoint Separation (m.)	Bottom Length (m.)
1	6.08	.00	.00	90.0 .0	427.88	427.88
2	6.18	.10	.10	89.1 .0	429.72	427.41
3	6.22	.14	.14	88.7 .0	430.20	427.23
4	6.27	.19	.19	88.3 .0	430.79	426.99
5	6.34	.26	.26	87.6 .0	431.51	426.67
6	6.44	.36	.36	86.8 .0	432.36	426.22
7	6.57	.49	.49	85.7 .0	433.36	425.62
8	6.76	.68	.68	84.3 .0	434.51	424.81
9	7.01	.93	.93	82.4 .0	435.80	423.73
10	7.36	1.28	1.28	80.0 .0	437.22	422.30
11	7.84	1.76	1.76	77.0 .0	438.75	420.42
12	8.50	2.42	2.42	73.5 .0	440.35	417.99
13	9.41	3.33	3.33	69.3 .0	441.97	414.87
14	10.66	4.58	4.58	64.6 .0	443.57	410.93
15	12.38	6.30	6.30	59.4 .0	445.12	406.01
16	14.74	8.66	8.66	54.0 .0	446.57	399.93
17	17.99	11.91	11.91	48.5 .0	447.92	392.50
18	22.46	16.38	16.38	43.2 .0	449.15	383.50
19	28.61	22.53	22.53	38.0 .0	450.27	372.68
20	37.06	30.98	30.98	33.3 .0	451.26	359.75
21	48.69	42.61	42.61	28.9 .0	452.16	344.38
22	64.68	58.60	58.60	25.0 .0	452.97	326.18
23	86.67	80.59	80.59	21.6 .0	453.72	304.66
24	116.91	110.84	110.84	18.5 .0	454.43	279.30
25	158.50	152.44	152.44	15.9 .0	455.12	249.44
26	215.71	209.64	209.64	13.6 .0	455.83	214.32
27	294.38	288.32	288.32	11.6 .0	456.61	173.06
28	402.58	396.53	396.53	9.9 .0	457.49	124.60
29	551.38	545.34	545.34	8.5 .0	458.56	67.69
30	756.03	750.00	750.00	7.2 .0	459.90	.83

```
**
***** I. Line Characteristics Summary *****
**
```

```
>>> Interpolation level 3 for line type B of 2 type(s)
      Vertical distance to nominal fairlead 2.38 m.
      Vertical separation between endpoints -7.48 m.
```

Segment Type	Length (m.)	Nominal Diameter (mm)	Submerged Weight (kgw/m.)	Elastic Coefficients		
				Alpha 1 (m.ton**-1)	Alpha 2 (m.ton**-2)	Alpha 3 (m.ton**-3)
1 Nylon	50.00	240.00	38.59	0.834E-03	-0.618E-06	0.168E-09
2 Chain	2.00	102.00	240.33	0.120E-04	0.000E+00	0.000E+00

Table Index	Buoy Tension (m.ton)	Tanker Tension (m.ton)	Horizontal Tension (m.ton)	Line angle Buoy (deg)	Line angle Tanker (deg)	Endpoint Separation (m.)	Bottom Length (m.)
1	.51	1.90	.00	90.0	-90.0	.00	.00
2	.86	1.55	.10	83.4	-86.3	15.48	.00
3	.87	1.56	.14	80.9	-84.9	19.04	.00
4	.88	1.56	.19	77.5	-83.1	23.10	.00
5	.89	1.58	.26	73.1	-80.5	27.58	.00
6	.92	1.60	.36	67.2	-77.1	32.29	.00
7	.98	1.64	.49	59.7	-72.6	36.94	.00
8	1.07	1.72	.68	50.8	-66.8	41.18	.00
9	1.23	1.85	.93	41.0	-59.9	44.68	.00
10	1.49	2.08	1.28	31.1	-52.0	47.30	.00
11	1.90	2.44	1.76	22.1	-43.9	49.06	.00
12	2.50	3.01	2.42	14.6	-36.3	50.17	.00
13	3.37	3.84	3.33	8.6	-29.8	50.84	.00
14	4.59	5.03	4.58	4.1	-24.4	51.24	.00
15	6.30	6.71	6.30	.8	-20.2	51.50	.00
16	8.66	9.06	8.66	-1.6	-17.1	51.71	.00
17	11.93	12.31	11.91	-3.4	-14.7	51.90	.00
18	16.44	16.81	16.38	-4.7	-12.9	52.11	.00
19	22.64	23.00	22.53	-5.6	-11.6	52.38	.00
20	31.17	31.52	30.98	-6.2	-10.6	52.74	.00
21	42.90	43.25	42.61	-6.7	-9.8	53.21	.00
22	59.03	59.37	58.60	-6.9	-9.3	53.84	.00
23	81.21	81.55	80.59	-7.1	-8.8	54.68	.00
24	111.70	112.03	110.84	-7.1	-8.4	55.79	.00
25	153.61	153.92	152.44	-7.1	-8.0	57.23	.00
26	211.20	211.50	209.64	-7.0	-7.6	59.05	.00
27	290.34	290.64	288.32	-6.8	-7.2	61.26	.00
28	399.13	399.41	396.53	-6.5	-6.9	63.83	.00
29	548.66	548.93	545.34	-6.3	-6.6	66.56	.00
30	754.28	754.54	750.00	-6.1	-6.3	69.09	.00

```
**
***** I. Line Characteristics Summary *****
**
```

```
>>> Interpolation level 4 for line type A of 2 type(s)
      Vertical distance to nominal fairlead .00 m.
      Vertical separation between endpoints 31.50 m.
```

Segment Type	Length (m.)	Nominal Diameter (mm)	Submerged Weight (kgw/m.)	Elastic Coefficients		
				Alpha 1 (m.ton**-1)	Alpha 2 (m.ton**-2)	Alpha 3 (m.ton**-3)
1 Chain	457.00	102.00	208.83	0.120E-04	0.000E+00	0.000E+00

Table Index	Top Tension (m.ton)	Anchor Tension (m.ton)	Horizontal Tension (m.ton)	Line angle Top (deg)	Line angle Anchor (deg)	Endpoint Separation (m.)	Bottom Length (m.)
1	6.58	.00	.00	90.0	.0	425.50	425.50
2	6.68	.10	.10	89.1	.0	427.37	425.03
3	6.72	.14	.14	88.8	.0	427.87	424.85
4	6.77	.19	.19	88.4	.0	428.48	424.61
5	6.84	.26	.26	87.8	.0	429.22	424.28
6	6.94	.36	.36	87.0	.0	430.10	423.83
7	7.07	.49	.49	86.0	.0	431.14	423.23
8	7.25	.68	.68	84.6	.0	432.34	422.42
9	7.51	.93	.93	82.9	.0	433.70	421.33
10	7.86	1.28	1.28	80.6	.0	435.21	419.88
11	8.34	1.76	1.76	77.8	.0	436.84	417.98
12	9.00	2.42	2.42	74.4	.0	438.55	415.51
13	9.91	3.33	3.33	70.4	.0	440.30	412.34
14	11.16	4.58	4.58	65.8	.0	442.05	408.31
15	12.87	6.30	6.30	60.7	.0	443.74	403.26
16	15.24	8.66	8.66	55.4	.0	445.34	397.01
17	18.49	11.91	11.91	49.9	.0	446.83	389.35
18	22.96	16.38	16.38	44.5	.0	448.20	380.05
19	29.10	22.53	22.53	39.3	.0	449.43	368.86
20	37.56	30.98	30.98	34.4	.0	450.54	355.47
21	49.18	42.61	42.61	30.0	.0	451.53	339.54
22	65.17	58.60	58.60	26.0	.0	452.43	320.64
23	87.16	80.59	80.59	22.4	.0	453.26	298.30
24	117.41	110.84	110.84	19.3	.0	454.03	271.94
25	159.00	152.44	152.44	16.5	.0	454.78	240.90
26	216.20	209.64	209.64	14.2	.0	455.54	204.39
27	294.88	288.32	288.32	12.1	.0	456.36	161.48
28	403.07	396.53	396.53	10.3	.0	457.28	111.07
29	551.87	545.34	545.34	8.8	.0	458.38	51.85
30	756.53	750.01	750.00	7.5	.3	459.75	.00

```
**
***** I. Line Characteristics Summary *****
**
```

```
>>> Interpolation level 4 for line type B of 2 type(s)
      Vertical distance to nominal fairlead .00 m.
      Vertical separation between endpoints -5.10 m.
```

Segment Type	Length (m.)	Nominal Diameter (mm)	Submerged Weight (kgw/m.)	Elastic Coefficients		
				Alpha 1 (m.ton**-1)	Alpha 2 (m.ton**-2)	Alpha 3 (m.ton**-3)
1 Nylon	50.00	240.00	38.59	0.834E-03	-0.618E-06	0.168E-09
2 Chain	2.00	102.00	240.33	0.120E-04	0.000E+00	0.000E+00

Table Index	Buoy Tension (m.ton)	Tanker Tension (m.ton)	Horizontal Tension (m.ton)	Line angle		Endpoint Separation (m.)	Bottom Length (m.)
				Buoy (deg)	Tanker (deg)		
1	.55	1.86	.00	90.0	-90.0	.00	.00
2	.91	1.51	.10	83.7	-86.2	15.51	.00
3	.91	1.51	.14	81.4	-84.8	19.07	.00
4	.92	1.52	.19	78.2	-82.8	23.15	.00
5	.94	1.53	.26	73.9	-80.2	27.65	.00
6	.97	1.55	.36	68.3	-76.7	32.38	.00
7	1.02	1.59	.49	61.2	-72.0	37.06	.00
8	1.11	1.67	.68	52.6	-66.1	41.33	.00
9	1.27	1.80	.93	43.1	-58.8	44.87	.00
10	1.53	2.02	1.28	33.5	-50.7	47.52	.00
11	1.94	2.38	1.76	24.7	-42.3	49.31	.00
12	2.53	2.93	2.42	17.2	-34.4	50.43	.00
13	3.40	3.76	3.33	11.3	-27.6	51.11	.00
14	4.61	4.94	4.58	6.8	-22.1	51.52	.00
15	6.31	6.61	6.30	3.5	-17.8	51.79	.00
16	8.66	8.95	8.66	1.0	-14.6	51.99	.00
17	11.91	12.18	11.91	-.8	-12.2	52.18	.00
18	16.39	16.65	16.38	-2.0	-10.4	52.40	.00
19	22.56	22.81	22.53	-3.0	-9.0	52.66	.00
20	31.04	31.29	30.98	-3.6	-8.0	53.01	.00
21	42.72	42.96	42.61	-4.1	-7.3	53.48	.00
22	58.77	59.01	58.60	-4.4	-6.7	54.11	.00
23	80.85	81.08	80.59	-4.6	-6.3	54.94	.00
24	111.21	111.43	110.84	-4.7	-5.9	56.04	.00
25	152.95	153.17	152.44	-4.7	-5.6	57.47	.00
26	210.33	210.54	209.64	-4.6	-5.3	59.27	.00
27	289.23	289.43	288.32	-4.5	-5.0	61.48	.00
28	397.70	397.90	396.53	-4.4	-4.8	64.04	.00
29	546.85	547.04	545.34	-4.3	-4.5	66.76	.00
30	751.96	752.13	750.00	-4.1	-4.3	69.29	.00

```
**
***** I. Line Characteristics Summary *****
**
```

```
>>> Interpolation level 5 for line type A of 2 type(s)
      Vertical distance to nominal fairlead -2.38 m.
      Vertical separation between endpoints 33.88 m.
```

Segment Type	Length (m.)	Nominal Diameter (mm)	Submerged Weight (kgw/m.)	Elastic Coefficients		
				Alpha 1 (m.ton**-1)	Alpha 2 (m.ton**-2)	Alpha 3 (m.ton**-3)
1 Chain	457.00	102.00	208.83	0.120E-04	0.000E+00	0.000E+00

Table Index	Top Tension (m.ton)	Anchor Tension (m.ton)	Horizontal Tension (m.ton)	Line angle		Endpoint Separation (m.)	Bottom Length (m.)
				Top (deg)	Anchor (deg)		
1	7.08	.00	.00	90.0	.0	423.12	423.12
2	7.18	.10	.10	89.2	.0	425.02	422.64
3	7.21	.14	.14	88.9	.0	425.53	422.47
4	7.26	.19	.19	88.5	.0	426.16	422.22
5	7.34	.26	.26	88.0	.0	426.92	421.90
6	7.43	.36	.36	87.2	.0	427.83	421.45
7	7.57	.49	.49	86.3	.0	428.91	420.84
8	7.75	.68	.68	85.0	.0	430.16	420.02
9	8.01	.93	.93	83.3	.0	431.59	418.93
10	8.36	1.28	1.28	81.2	.0	433.18	417.47
11	8.84	1.76	1.76	78.5	.0	434.90	415.55
12	9.50	2.42	2.42	75.2	.0	436.73	413.04
13	10.40	3.33	3.33	71.3	.0	438.61	409.81
14	11.65	4.58	4.58	66.9	.0	440.49	405.70
15	13.37	6.30	6.30	61.9	.0	442.32	400.54
16	15.74	8.66	8.66	56.6	.0	444.07	394.13
17	18.99	11.91	11.91	51.1	.0	445.71	386.26
18	23.45	16.38	16.38	45.7	.0	447.21	376.69
19	29.60	22.53	22.53	40.4	.0	448.57	365.15
20	38.06	30.98	30.98	35.5	.0	449.79	351.32
21	49.68	42.61	42.61	30.9	.0	450.89	334.83
22	65.67	58.60	58.60	26.8	.0	451.87	315.28
23	87.66	80.59	80.59	23.2	.0	452.78	292.14
24	117.90	110.84	110.84	19.9	.0	453.62	264.83
25	159.50	152.44	152.44	17.1	.0	454.43	232.66
26	216.70	209.64	209.64	14.7	.0	455.24	194.81
27	295.37	288.32	288.32	12.5	.0	456.10	150.31
28	403.57	396.53	396.53	10.7	.0	457.07	98.03
29	552.37	545.34	545.34	9.2	.0	458.20	36.60
30	757.05	750.04	750.00	7.8	.6	459.58	.00

**
 ***** I. Line Characteristics Summary *****
 **

>>> Interpolation level 5 for line type B of 2 type(s)
 Vertical distance to nominal fairlead -2.38 m.
 Vertical separation between endpoints -2.72 m.

Segment Type	Length (m.)	Nominal Diameter (mm)	Submerged Weight (kgw/m.)	Elastic Coefficients		
				Alpha 1 (m.ton** ⁻¹)	Alpha 2 (m.ton** ⁻²)	Alpha 3 (m.ton** ⁻³)
1 Nylon	50.00	240.00	38.59	0.834E-03	-0.618E-06	0.168E-09
2 Chain	2.00	102.00	240.33	0.120E-04	0.000E+00	0.000E+00

Table Index	Buoy Tension (m.ton)	Tanker Tension (m.ton)	Horizontal Tension (m.ton)	Line angle		Endpoint Separation (m.)	Bottom Length (m.)
				Buoy (deg)	Tanker (deg)		
1	.60	1.81	.00	90.0	-90.0	.00	.00
2	.96	1.46	.10	84.0	-86.1	15.52	.00
3	.96	1.47	.14	81.8	-84.6	19.09	.00
4	.97	1.47	.19	78.7	-82.6	23.18	.00
5	.98	1.48	.26	74.7	-79.9	27.69	.00
6	1.01	1.50	.36	69.3	-76.2	32.43	.00
7	1.07	1.54	.49	62.5	-71.4	37.13	.00
8	1.16	1.62	.68	54.3	-65.3	41.43	.00
9	1.32	1.74	.93	45.1	-57.8	44.99	.00
10	1.58	1.96	1.28	35.8	-49.3	47.65	.00
11	1.98	2.32	1.76	27.1	-40.6	49.46	.00
12	2.57	2.87	2.42	19.8	-32.4	50.60	.00
13	3.43	3.69	3.33	14.0	-25.4	51.28	.00
14	4.64	4.86	4.58	9.5	-19.8	51.70	.00
15	6.33	6.53	6.30	6.1	-15.4	51.96	.00
16	8.68	8.86	8.66	3.7	-12.1	52.17	.00
17	11.92	12.08	11.91	1.9	-9.6	52.36	.00
18	16.38	16.53	16.38	.6	-7.8	52.57	.00
19	22.53	22.67	22.53	-.4	-6.5	52.84	.00
20	30.99	31.13	30.98	-1.1	-5.5	53.19	.00
21	42.62	42.76	42.61	-1.5	-4.8	53.65	.00
22	58.63	58.76	58.60	-1.9	-4.2	54.27	.00
23	80.65	80.77	80.59	-2.1	-3.8	55.10	.00
24	110.92	111.04	110.84	-2.2	-3.5	56.20	.00
25	152.56	152.68	152.44	-2.3	-3.2	57.61	.00
26	209.82	209.93	209.64	-2.3	-3.0	59.41	.00
27	288.56	288.67	288.32	-2.3	-2.8	61.61	.00
28	396.84	396.94	396.53	-2.3	-2.6	64.16	.00
29	545.75	545.85	545.34	-2.2	-2.5	66.88	.00
30	750.54	750.63	750.00	-2.2	-2.3	69.41	.00

**
 ***** I. Line Characteristics Summary *****
 **

>>> Interpolation level 6 for line type A of 2 type(s)
 Vertical distance to nominal fairlead -4.77 m.
 Vertical separation between endpoints 36.27 m.

Segment Type	Length (m.)	Nominal Diameter (mm)	Submerged Weight (kgw/m.)	Elastic Coefficients		
				Alpha 1 (m.ton** ⁻¹)	Alpha 2 (m.ton** ⁻²)	Alpha 3 (m.ton** ⁻³)
1 Chain	457.00	102.00	208.83	0.120E-04	0.000E+00	0.000E+00

Table Index	Top Tension (m.ton)	Anchor Tension (m.ton)	Horizontal Tension (m.ton)	Line angle		Endpoint Separation (m.)	Bottom Length (m.)
				Top (deg)	Anchor (deg)		
1	7.57	.00	.00	90.0	.0	420.73	420.73
2	7.67	.10	.10	89.3	.0	422.67	420.26
3	7.71	.14	.14	89.0	.0	423.19	420.08
4	7.76	.19	.19	88.6	.0	423.83	419.84
5	7.83	.26	.26	88.1	.0	424.62	419.51
6	7.93	.36	.36	87.4	.0	425.56	419.06
7	8.07	.49	.49	86.5	.0	426.67	418.45
8	8.25	.68	.68	85.3	.0	427.98	417.63
9	8.50	.93	.93	83.7	.0	429.46	416.53
10	8.85	1.28	1.28	81.7	.0	431.13	415.06
11	9.33	1.76	1.76	79.1	.0	432.95	413.12
12	9.99	2.42	2.42	76.0	.0	434.88	410.58
13	10.90	3.33	3.33	72.2	.0	436.88	407.30
14	12.15	4.58	4.58	67.9	.0	438.90	403.12
15	13.87	6.30	6.30	63.0	.0	440.88	397.85
16	16.23	8.66	8.66	57.8	.0	442.77	391.30
17	19.48	11.91	11.91	52.3	.0	444.55	383.22
18	23.95	16.38	16.38	46.9	.0	446.19	373.39
19	30.10	22.53	22.53	41.5	.0	447.67	361.51
20	38.55	30.98	30.98	36.5	.0	449.01	347.26
21	50.18	42.61	42.61	31.9	.0	450.22	330.26
22	66.17	58.60	58.60	27.7	.0	451.30	310.07
23	88.16	80.59	80.59	23.9	.0	452.28	286.17
24	118.40	110.84	110.84	20.6	.0	453.19	257.95
25	160.00	152.44	152.44	17.7	.0	454.07	224.69
26	217.20	209.64	209.64	15.2	.0	454.93	185.55
27	295.87	288.32	288.32	13.0	.0	455.84	139.52
28	404.06	396.53	396.53	11.1	.0	456.84	85.42
29	552.86	545.34	545.34	9.5	.0	458.00	21.86
30	757.59	750.09	750.00	8.1	.9	459.40	.00

**
 ***** I. Line Characteristics Summary *****
 **

>>> Interpolation level 6 for line type B of 2 type(s)
 Vertical distance to nominal fairlead -4.77 m.
 Vertical separation between endpoints -.33 m.

Segment Type	Length (m.)	Nominal Diameter (mm)	Submerged Weight (kgw/m.)	Elastic Coefficients		
				Alpha 1 (m.ton**-1)	Alpha 2 (m.ton**-2)	Alpha 3 (m.ton**-3)
1 Nylon	50.00	240.00	38.59	0.834E-03	-0.618E-06	0.168E-09
2 Chain	2.00	102.00	240.33	0.120E-04	0.000E+00	0.000E+00

Table Index	Buoy Tension (m.ton)	Tanker Tension (m.ton)	Horizontal Tension (m.ton)	-- Line angle -- Buoy (deg) Tanker (deg)	Endpoint Separation (m.)	Bottom Length (m.)
1	.64	1.77	.00	90.0 -90.0	.00	.00
2	1.00	1.42	.10	84.3 -86.0	15.53	.00
3	1.01	1.42	.14	82.1 -84.4	19.10	.00
4	1.01	1.43	.19	79.3 -82.4	23.19	.00
5	1.03	1.44	.26	75.4 -79.6	27.70	.00
6	1.06	1.46	.36	70.3 -75.8	32.45	.00
7	1.11	1.50	.49	63.7 -70.8	37.15	.00
8	1.21	1.57	.68	55.8 -64.4	41.45	.00
9	1.36	1.69	.93	47.0 -56.6	45.03	.00
10	1.62	1.91	1.28	37.9 -47.8	47.70	.00
11	2.02	2.26	1.76	29.5 -38.8	49.52	.00
12	2.62	2.81	2.42	22.3 -30.3	50.66	.00
13	3.47	3.62	3.33	16.5 -23.1	51.35	.00
14	4.68	4.80	4.58	12.1 -17.3	51.76	.00
15	6.37	6.46	6.30	8.8 -12.9	52.03	.00
16	8.71	8.78	8.66	6.3 -9.5	52.24	.00
17	11.95	12.00	11.91	4.5 -7.1	52.43	.00
18	16.41	16.45	16.38	3.2 -5.2	52.64	.00
19	22.54	22.58	22.53	2.2 -3.9	52.91	.00
20	30.99	31.02	30.98	1.5 -2.9	53.25	.00
21	42.62	42.64	42.61	1.0 -2.2	53.72	.00
22	58.60	58.63	58.60	.6 -1.7	54.34	.00
23	80.59	80.61	80.59	.4 -1.3	55.16	.00
24	110.84	110.86	110.84	.2 -1.1	56.26	.00
25	152.44	152.45	152.44	0.0 -.9	57.67	.00
26	209.64	209.66	209.64	0.0 -.7	59.47	.00
27	288.32	288.34	288.32	-1.1 -.6	61.66	.00
28	396.53	396.54	396.53	-2.2 -.5	64.21	.00
29	545.34	545.35	545.34	-2.2 -.4	66.93	.00
30	750.00	750.02	750.00	-2.2 -.4	69.45	.00

**
 ***** I. Line Characteristics Summary *****
 **

>>> Interpolation level 7 for line type A of 2 type(s)
 Vertical distance to nominal fairlead -7.15 m.
 Vertical separation between endpoints 38.65 m.

Segment Type	Length (m.)	Nominal Diameter (mm)	Submerged Weight (kgw/m.)	Elastic Coefficients		
				Alpha 1 (m.ton**-1)	Alpha 2 (m.ton**-2)	Alpha 3 (m.ton**-3)
1 Chain	457.00	102.00	208.83	0.120E-04	0.000E+00	0.000E+00

Table Index	Top Tension (m.ton)	Anchor Tension (m.ton)	Horizontal Tension (m.ton)	-- Line angle -- Top (deg) Anchor (deg)	Endpoint Separation (m.)	Bottom Length (m.)
1	8.07	.00	.00	90.0 .0	418.35	418.35
2	8.17	.10	.10	89.3 .0	420.32	417.88
3	8.21	.14	.14	89.0 .0	420.85	417.70
4	8.26	.19	.19	88.7 .0	421.51	417.46
5	8.33	.26	.26	88.2 .0	422.31	417.13
6	8.43	.36	.36	87.6 .0	423.28	416.68
7	8.56	.49	.49	86.7 .0	424.43	416.07
8	8.75	.68	.68	85.6 .0	425.77	415.24
9	9.00	.93	.93	84.1 .0	427.32	414.13
10	9.35	1.28	1.28	82.1 .0	429.06	412.65
11	9.83	1.76	1.76	79.7 .0	430.97	410.69
12	10.49	2.42	2.42	76.7 .0	433.01	408.13
13	11.40	3.33	3.33	73.0 .0	435.13	404.81
14	12.65	4.58	4.58	68.8 .0	437.28	400.56
15	14.37	6.30	6.30	64.0 .0	439.40	395.19
16	16.73	8.66	8.66	58.8 .0	441.45	388.49
17	19.98	11.91	11.91	53.4 .0	443.37	380.23
18	24.45	16.38	16.38	47.9 .0	445.14	370.15
19	30.60	22.53	22.53	42.6 .0	446.76	357.95
20	39.05	30.98	30.98	37.5 .0	448.22	343.30
21	50.68	42.61	42.61	32.8 .0	449.52	325.81
22	66.67	58.60	58.60	28.5 .0	450.70	305.01
23	88.66	80.59	80.59	24.6 .0	451.77	280.37
24	118.90	110.84	110.84	21.2 .0	452.75	251.27
25	160.49	152.44	152.44	18.2 .0	453.69	216.96
26	217.69	209.64	209.64	15.6 .0	454.61	176.57
27	296.36	288.32	288.32	13.4 .0	455.56	129.06
28	404.56	396.53	396.53	11.4 .0	456.60	73.22
29	553.36	545.34	545.34	9.8 .0	457.81	7.59
30	758.16	750.16	750.00	8.4 1.2	459.21	.00

```
**
***** I. Line Characteristics Summary *****
**
```

```
>>> Interpolation level 7 for line type B of 2 type(s)
      Vertical distance to nominal fairlead -7.15 m.
      Vertical separation between endpoints 2.05 m.
```

Segment Type	Length (m.)	Nominal Diameter (mm)	Submerged Weight (kgw/m.)	Elastic Coefficients		
				Alpha 1 (m.ton** ⁻¹)	Alpha 2 (m.ton** ⁻²)	Alpha 3 (m.ton** ⁻³)
1 Nylon	50.00	240.00	38.59	0.834E-03	-0.618E-06	0.168E-09
2 Chain	2.00	102.00	240.33	0.120E-04	0.000E+00	0.000E+00

Table Index	Buoy Tension (m.ton)	Tanker Tension (m.ton)	Horizontal Tension (m.ton)	Line angle		Endpoint Separation (m.)	Bottom Length (m.)
				Buoy (deg)	Tanker (deg)		
1	.69	1.72	.00	90.0	-90.0	.00	.00
2	1.05	1.37	.10	84.5	-85.8	15.52	.00
3	1.05	1.37	.14	82.5	-84.3	19.09	.00
4	1.06	1.38	.19	79.7	-82.1	23.17	.00
5	1.08	1.39	.26	76.0	-79.2	27.68	.00
6	1.11	1.41	.36	71.1	-75.3	32.43	.00
7	1.16	1.45	.49	64.9	-70.1	37.13	.00
8	1.25	1.52	.68	57.3	-63.5	41.42	.00
9	1.41	1.64	.93	48.7	-55.4	44.99	.00
10	1.67	1.85	1.28	39.9	-46.3	47.66	.00
11	2.07	2.20	1.76	31.7	-36.9	49.48	.00
12	2.66	2.75	2.42	24.7	-28.2	50.62	.00
13	3.52	3.56	3.33	19.0	-20.8	51.31	.00
14	4.73	4.74	4.58	14.6	-14.9	51.72	.00
15	6.42	6.40	6.30	11.3	-10.3	51.99	.00
16	8.77	8.72	8.66	8.9	-7.0	52.20	.00
17	12.00	11.95	11.91	7.1	-4.5	52.39	.00
18	16.46	16.40	16.38	5.8	-2.7	52.60	.00
19	22.61	22.53	22.53	4.8	-1.3	52.87	.00
20	31.06	30.98	30.98	4.1	-.4	53.22	.00
21	42.69	42.61	42.61	3.5	.3	53.68	.00
22	58.69	58.61	58.60	3.1	.8	54.30	.00
23	80.69	80.61	80.59	2.8	1.1	55.13	.00
24	110.95	110.87	110.84	2.6	1.4	56.22	.00
25	152.57	152.49	152.44	2.4	1.5	57.64	.00
26	209.81	209.72	209.64	2.3	1.6	59.44	.00
27	288.52	288.44	288.32	2.1	1.6	61.63	.00
28	396.76	396.69	396.53	2.0	1.6	64.18	.00
29	545.63	545.55	545.34	1.9	1.6	66.90	.00
30	750.36	750.29	750.00	1.8	1.6	69.43	.00

```
**
***** II. Equilibrium Condition Summary *****
** (Tanker Data; Offsets Relative to Buoy Attachment Point) **
```

```
>>> User-specified still-water conditions produced the
      following net mooring force and moment components:
```

	Global system (Gravity Vertical)	Vessel system (Gravity Vertical)
X Mooring Force	.00 m.ton	.00 m.ton
Y Mooring Force	.00 m.ton	.00 m.ton
Z Mooring Force	-.55 m.ton	-.55 m.ton
Total Plan View Force	.00 m.ton	.00 m.ton
Plan View Force Angle	.00 deg	.00 deg
X Mooring Moment	.00 ton-meter	.00 ton-meter
Y Mooring Moment	96.56 ton-meter	96.56 ton-meter
Z Mooring Moment	.00 ton-meter	.00 ton-meter

```
----> These mooring moments are reported about the Vessel coordinate <---
      (Vx,Vy,Vz) = ( 0.000E-01, 0.000E-01, 0.000E-01)
```

```
>>> User-specified still-water line conditions
```

Line #/Type	Total Tension (m.ton)		Horizontal Tension (m.ton)	Endpoint Separation (m.)	Bottom Length (m.)	Buoy-end Line Angle (deg)	
	Buoy	Tanker				Plan	Profile
7/b	.55	1.86	.00	.00	.00	-.00	90.00

```

**
***** II. Equilibrium Condition Summary *****
**
          (Buoy Data)
    
```

++> User-specified still-water conditions produced the following net mooring force and moment components:

	Global system (Gravity Vertical)	Vessel system (Gravity Vertical)
X Mooring Force	0.00 m.ton	0.00 m.ton
Y Mooring Force	0.00 m.ton	0.00 m.ton
Z Mooring Force	-76.61 m.ton	-76.61 m.ton
Total Plan View Force	0.00 m.ton	0.00 m.ton
Plan View Force Angle	59.04 deg	59.04 deg
X Mooring Moment	.00 ton-meter	.00 ton-meter
Y Mooring Moment	.00 ton-meter	.00 ton-meter
Z Mooring Moment	0.00 ton-meter	0.00 ton-meter

---> These mooring moments are reported about the Vessel coordinate <---
(Vx,Vy,Vz) = (0.000E-01, 0.000E-01, 0.000E-01)

>>> User-specified still-water line conditions

Line #/Type	Total Tension (m.ton)		Horizontal Tension (m.ton)	Endpoint Separation (m.)	Bottom Length (m.)	Buoy-end Line Angle Plan Profile (deg)	
	Buoy	Anchor				Plan	Profile
1/a	15.60	9.02	9.02	445.51	396.15	- .00	54.75
2/a	15.60	9.02	9.02	445.51	396.15	60.00	54.75
3/a	15.60	9.02	9.02	445.51	396.15	120.00	54.75
4/a	15.60	9.02	9.02	445.51	396.15	180.00	54.75
5/a	15.60	9.02	9.02	445.51	396.15	240.00	54.75
6/a	15.60	9.02	9.02	445.51	396.15	300.00	54.75

```

**
***** II. Equilibrium Condition Summary *****
**
          (Buoy Data)
    
```

++> Specified environmental conditions, applied forces and moments produced the following net mooring force and moment components:

	Global system (Gravity Vertical)	Vessel system (Gravity Vertical)
X Mooring Force	0.00 m.ton	0.00 m.ton
Y Mooring Force	0.00 m.ton	0.00 m.ton
Z Mooring Force	-76.61 m.ton	-76.61 m.ton
Total Plan View Force	0.00 m.ton	0.00 m.ton
Plan View Force Angle	59.04 deg	59.04 deg
X Mooring Moment	.00 ton-meter	.00 ton-meter
Y Mooring Moment	.00 ton-meter	.00 ton-meter
Z Mooring Moment	0.00 ton-meter	0.00 ton-meter

---> These mooring moments are reported about the Vessel coordinate <---
(Vx,Vy,Vz) = (0.000E-01, 0.000E-01, 0.000E-01)

++> Specified environmental conditions, applied forces and moments produced the following global quasi-static mooring centroid displacements:

	Global system	Vessel system
X Displacement	0.00 m.	0.00 m.
Y Displacement	0.00 m.	0.00 m.
Z Displacement	.00 m.	.00 m.
Total Plan View Offset	0.00 m.	0.00 m.
Plan View Offset Angle	59.18 deg	59.18 deg
Yaw Displacement	0.00 deg	.00 deg
Vessel Orientation	0.00 deg	.00 deg

>>> Estimated mean line conditions in specified environment

Line #/Type	Total Tension (m.ton)		Horizontal Tension (m.ton)	Endpoint Separation (m.)	Bottom Length (m.)	Buoy-end Line Angle Plan Profile (deg)	
	Buoy	Anchor				Plan	Profile
1/a	15.60	9.02	9.02	445.51	396.15	360.00	54.75
2/a	15.60	9.02	9.02	445.51	396.15	60.00	54.75
3/a	15.60	9.02	9.02	445.51	396.15	120.00	54.75
4/a	15.60	9.02	9.02	445.51	396.15	180.00	54.75
5/a	15.60	9.02	9.02	445.51	396.15	240.00	54.75
6/a	15.60	9.02	9.02	445.51	396.15	300.00	54.75

***** III. Lateral Offset Restoring Characteristics *****

```

:-----:
::
:: Offset Type: Rectilinear Lateral Translation ::
::
:: Plan-View Offset Direction = 180.00 deg ::
::
:-----:

```

Moments reported about Vessel coordinate
(Vx,Vy,Vz) = (0.000E-01, 0.000E-01, 0.000E-01)

---- Most Exposed Line Characteristics: Buoy Data ----

Buoy Offset (m.)	Line #	-- Fairlead Tensions --			Unstretched Suspended Length (m.)	Anchor Forces Rel. to Bottom		Total Restoring Force (m.ton)
		Total (m.ton)	Horiz. (m.ton)	Vert. (m.ton)		<Parallel> (m.ton)	<Perp.> (m.ton)	
.0	1	15.60	9.02	-12.77	60.9	9.02	-0.00	-1.431E-06
1.0	1	17.78	11.20	-13.88	66.0	11.20	-0.00	4.877E-12
2.0	1	20.70	14.12	-15.26	72.3	14.12	-0.00	-7.535E-14
3.0	1	24.51	17.93	-16.82	79.9	17.93	-0.00	-2.250E-14
4.0	1	29.70	23.12	-18.68	89.2	23.12	-0.00	-4.164E-14
5.0	1	37.32	30.75	-21.17	101.3	30.75	-0.00	1.225E-13
6.0	1	48.87	42.30	-24.50	117.2	42.30	-0.00	1.535E-13
7.0	1	67.14	60.57	-29.07	138.6	60.57	-0.00	2.377E-13
8.0	1	96.94	90.37	-35.38	167.5	90.37	-0.00	4.941E-13
9.0	1	143.84	137.27	-43.33	205.2	137.27	-0.00	1.056E-12
10.0	1	213.50	206.93	-52.61	251.4	206.93	-0.00	1.126E-12
11.0	1	312.13	305.57	-63.96	304.1	305.57	-0.00	1.931E-12
12.0	1	433.32	426.77	-75.50	358.5	426.77	-0.00	3.914E-12
13.0	1	570.48	563.95	-86.38	412.1	563.95	.26	3.706E-12
> 14.0	1	720.62	714.09	-97.30	457.0	714.09	2.93	4.947E-12
15.0	1	870.77	864.24	-103.21	457.0	864.24	6.71	5.876E-12
16.0	1	1020.91	1014.39	-104.14	457.0	1014.39	11.59	7.185E-12
17.0	1	1171.03	1164.54	-100.09	457.0	1164.54	17.56	8.530E-12
18.0	1	1321.14	1314.68	-91.09	457.0	1314.68	24.63	8.585E-12
19.0	1	1471.22	1464.83	-77.14	457.0	1464.83	32.80	1.006E-11
20.0	1	1621.27	1614.98	-58.24	457.0	1614.98	42.07	8.919E-12
21.0	1	1771.28	1765.13	-34.39	457.0	1765.13	52.44	1.183E-11
22.0	1	1921.25	1915.28	-5.59	457.0	1915.28	63.91	2.761E-10
23.0	1	2071.16	2065.42	28.19	457.0	2065.42	76.48	1.119E-11
24.0	1	2221.01	2215.57	66.95	457.0	2215.57	90.15	1.561E-11

++> Offset range exceeded lateral interpolation table bounds.
First occurrence was in mooring line 7, offset value 14.00

***** III. Lateral Offset Restoring Characteristics *****

```

:-----:
::
:: Offset Type: Rectilinear Lateral Translation ::
::
:: Plan-View Offset Direction = 180.00 deg ::
::
:-----:

```

Moments reported about Vessel coordinate
(Vx,Vy,Vz) = (0.000E-01, 0.000E-01, 0.000E-01)

----- Hawser Characteristics -----

>>> Line Number 7, Line Type 2, Unstretched Length: 52.00 m. <<<

Net Vessel Offset (m.)	Buoy Offset (m.)	-- Buoy-End Tensions --			Vessel Forces Rel. to Bottom		Total Restoring Force (m.ton)
		Total (m.ton)	Horiz. (m.ton)	Vert. (m.ton)	<Parallel> (m.ton)	<Perp.> (m.ton)	
.00	.00	.55	.00	-.55	.00	.55	0.000E-01
52.71	1.00	5.80	5.78	-.46	5.78	-2.00	5.778E+00
54.19	2.00	11.96	11.96	.16	11.96	-2.57	1.196E+01
55.51	3.00	18.90	18.88	.80	18.88	-3.27	1.888E+01
56.86	4.00	27.34	27.29	1.60	27.29	-4.07	2.729E+01
58.29	5.00	37.97	37.88	2.59	37.88	-5.06	3.788E+01
59.88	6.00	53.00	52.85	3.97	52.85	-6.44	5.285E+01
61.72	7.00	75.04	74.80	5.94	74.80	-8.40	7.480E+01
63.95	8.00	108.75	108.39	8.87	108.39	-11.29	1.084E+02
66.71	9.00	160.65	160.12	13.13	160.12	-15.57	1.601E+02
69.98	10.00	235.55	234.79	18.94	234.79	-21.41	2.348E+02
73.71	11.00	341.39	340.35	26.66	340.35	-29.13	3.403E+02
77.36	12.00	470.38	469.04	35.59	469.04	-38.06	4.690E+02
80.64	13.00	618.10	616.44	45.47	616.44	-47.94	6.164E+02
> 83.65	14.00	781.09	779.07	56.05	779.07	-58.42	7.791E+02
86.69	15.00	946.81	944.44	66.21	944.44	-68.16	9.444E+02
89.81	16.00	1118.68	1115.94	76.09	1115.94	-77.28	1.116E+03
92.99	17.00	1295.28	1292.16	85.57	1292.16	-85.60	1.292E+03
96.23	18.00	1477.49	1473.96	94.62	1473.96	-93.08	1.474E+03
99.61	19.00	1670.83	1666.89	103.42	1666.89	-99.79	1.667E+03
103.09	20.00	1871.35	1866.98	111.67	1866.98	-105.41	1.867E+03
106.63	21.00	2077.93	2073.11	119.24	2073.11	-109.78	2.073E+03
110.33	22.00	2296.69	2291.40	126.22	2291.40	-112.84	2.291E+03
114.07	23.00	2519.12	2513.35	132.23	2513.35	-114.29	2.513E+03
117.91	24.00	2749.62	2743.35	137.31	2743.35	-114.03	2.743E+03

++> Offset range exceeded lateral interpolation table bounds.
First occurrence was in mooring line 7, offset value 14.00

***** III. Lateral Offset Restoring Characteristics *****

```

:-----:
::
:: Offset Type: Rectilinear Lateral Translation ::
::
:: Plan-View Offset Direction = 180.00 deg ::
::
:-----:

```

Moments reported about Vessel coordinate
(Vx,Vy,Vz) = (0.000E-01, 0.000E-01, 0.000E-01)

---- Most Exposed Line Potential Energy: Buoy Data ----

Buoy Offset (m.)	Line #	-- Fairlead Tensions --			Unstretched Suspended Length (m.)	Line Potential Energy (ton-meter)	Total Buoy Potential Energy (ton-meter)
		Total (m.ton)	Horiz. (m.ton)	Vert. (m.ton)			
.0	1	15.60	9.02	-12.77	60.9	8.742E+01	5.245E+02
1.0	1	17.78	11.20	-13.88	66.0	9.702E+01	5.265E+02
2.0	1	20.70	14.12	-15.26	72.3	1.102E+02	5.351E+02
3.0	1	24.51	17.93	-16.82	79.9	1.263E+02	5.520E+02
4.0	1	29.70	23.12	-18.68	89.2	1.467E+02	5.739E+02
5.0	1	37.32	30.75	-21.17	101.3	1.735E+02	6.064E+02
6.0	1	48.87	42.30	-24.50	117.2	2.101E+02	6.531E+02
7.0	1	67.14	60.57	-29.07	138.6	2.613E+02	7.142E+02
8.0	1	96.94	90.37	-35.38	167.5	3.351E+02	8.062E+02
9.0	1	143.84	137.27	-43.33	205.2	4.472E+02	9.373E+02
10.0	1	213.50	206.93	-52.61	251.4	6.170E+02	1.133E+03
11.0	1	312.13	305.57	-63.96	304.1	8.718E+02	1.418E+03
12.0	1	433.32	426.77	-75.50	358.5	1.236E+03	1.822E+03
13.0	1	570.48	563.95	-86.38	412.1	1.730E+03	2.362E+03
> 14.0	1	720.62	714.09	-97.30	457.0	2.371E+03	3.062E+03
15.0	1	870.77	864.24	-103.21	457.0	3.140E+03	3.905E+03
16.0	1	1020.91	1014.39	-104.14	457.0	4.033E+03	4.888E+03
17.0	1	1171.03	1164.54	-100.09	457.0	5.049E+03	6.018E+03
18.0	1	1321.14	1314.68	-91.09	457.0	6.189E+03	7.300E+03
19.0	1	1471.22	1464.83	-77.14	457.0	7.452E+03	8.745E+03
20.0	1	1621.27	1614.98	-58.24	457.0	8.838E+03	1.036E+04
21.0	1	1771.28	1765.13	-34.39	457.0	1.035E+04	1.215E+04
22.0	1	1921.25	1915.28	-5.59	457.0	1.198E+04	1.412E+04
23.0	1	2071.16	2065.42	28.19	457.0	1.374E+04	1.629E+04
24.0	1	2221.01	2215.57	66.95	457.0	1.562E+04	1.866E+04

++> Offset range exceeded lateral interpolation table bounds.
First occurrence was in mooring line 7, offset value 14.00

***** III. Lateral Offset Restoring Characteristics *****

```

:-----:
::
:: Offset Type: Rectilinear Lateral Translation ::
::
:: Plan-View Offset Direction = 180.00 deg ::
::
:-----:

```

Moments reported about Vessel coordinate
(Vx,Vy,Vz) = (0.000E-01, 0.000E-01, 0.000E-01)

----- Hawser Energy Characteristics -----

>>> Line Number 7, Line Type 2, Unstretched Length: 52.00 m. <<<

Net Vessel Offset (m.)	Buoy Offset (m.)	-- Buoy-End Tensions --			Hawser Potential Energy -----	Buoy Potential Energy (ton-meter)	System Potential Energy -----
		Total (m.ton)	Horiz. (m.ton)	Vert. (m.ton)			
.00	.00	.55	.00	-.55	0.000E-01	5.245E+02	5.245E+02
51.71	1.00	5.80	5.78	-.46	-6.588E+02	5.265E+02	-1.323E+02
52.19	2.00	11.96	11.96	.16	-1.862E+03	5.351E+02	-1.326E+03
52.51	3.00	18.90	18.88	.80	-2.599E+03	5.520E+02	-2.047E+03
52.86	4.00	27.34	27.29	1.60	-3.616E+03	5.739E+02	-3.042E+03
53.29	5.00	37.97	37.88	2.59	-5.023E+03	6.064E+02	-4.416E+03
53.88	6.00	53.00	52.85	3.97	-6.968E+03	6.531E+02	-6.315E+03
54.72	7.00	75.04	74.80	5.94	-9.662E+03	7.142E+02	-8.948E+03
55.95	8.00	108.75	108.39	8.87	-1.340E+04	8.062E+02	-1.259E+04
57.71	9.00	160.65	160.12	13.13	-2.607E+04	9.373E+02	-2.513E+04
59.98	10.00	235.55	234.79	18.94	-3.641E+04	1.133E+03	-3.527E+04
62.71	11.00	341.39	340.35	26.66	-5.104E+04	1.418E+03	-4.962E+04
65.36	12.00	470.38	469.04	35.59	-7.199E+04	1.822E+03	-7.017E+04
67.64	13.00	618.10	616.44	45.47	-1.022E+05	2.362E+03	-9.982E+04
69.65	14.00	781.09	779.07	56.05	-1.013E+05	3.062E+03	-9.827E+04
71.69	15.00	946.81	944.44	66.21	-1.001E+05	3.905E+03	-9.622E+04
73.81	16.00	1118.68	1115.94	76.09	-9.852E+04	4.888E+03	-9.364E+04
75.99	17.00	1295.28	1292.16	85.57	-9.650E+04	6.018E+03	-9.048E+04
78.23	18.00	1477.49	1473.96	94.62	-9.400E+04	7.300E+03	-8.670E+04
80.61	19.00	1670.83	1666.89	103.42	-9.091E+04	8.745E+03	-8.216E+04
83.09	20.00	1871.35	1866.98	111.67	-8.721E+04	1.036E+04	-7.686E+04
85.63	21.00	2077.93	2073.11	119.24	-8.289E+04	1.215E+04	-7.074E+04
88.33	22.00	2296.69	2291.40	126.22	-7.774E+04	1.412E+04	-6.362E+04
91.07	23.00	2519.12	2513.35	132.23	-7.190E+04	1.629E+04	-5.561E+04
93.91	24.00	2749.62	2743.35	137.31	-6.521E+04	1.866E+04	-4.655E+04

++> Offset range exceeded lateral interpolation table bounds.
First occurrence was in mooring line 7, offset value 14.00

***** III. Lateral Offset Restoring Characteristics *****

```

:
:
: Offset Type: Rectilinear Lateral Translation :
:
: Plan-View Offset Direction = 180.00 deg :
:
:
:
:

```

Moments reported about Vessel coordinate
(Vx,Vy,Vz) = (0.000E-01, 0.000E-01, 0.000E-01)

Total Restoring Characteristics
and Cross-Coupling Summary

>>> Buoy Data <<<

Offset (m.)	Total Restoring Force (m.ton)	---- Induced Moments ----			---- Vessel-Relative Forces ----			
		Roll	Pitch	Yaw	Orthogonal to Offset	Surge	Sway	Heave
		----- (m.ton*m.) -----			----- (m.ton)-----			
.0	0.0	0.00E-01	0.00E-01	-8.31E-06	77.2	0.0	0.0	-76.6
1.0	0.0	1.91E-04	-1.69E+01	1.14E-05	77.7	5.8	0.0	-77.3
2.0	0.0	-6.86E-06	-3.57E+01	3.67E-06	77.9	12.0	0.0	-78.1
3.0	0.0	1.22E-06	-5.85E+01	-1.45E-05	78.5	18.9	0.0	-79.3
4.0	0.0	9.39E-06	-8.81E+01	-8.70E-06	79.9	27.3	0.0	-81.5
5.0	0.0	1.01E-05	-1.30E+02	9.54E-07	81.6	37.9	0.0	-84.2
6.0	0.0	3.40E-06	-1.93E+02	5.48E-06	84.5	52.9	0.0	-88.5
7.0	0.0	4.81E-06	-2.93E+02	-4.29E-06	87.9	74.8	0.0	-93.8
8.0	0.0	6.98E-06	-4.59E+02	-2.10E-05	92.6	108.4	0.0	-101.5
9.0	0.0	1.03E-05	-7.30E+02	-4.17E-05	98.4	160.1	0.0	-111.5
10.0	0.0	1.51E-05	-1.14E+03	-5.63E-05	103.4	234.8	0.0	-122.4
11.0	0.0	2.19E-05	-1.74E+03	-9.78E-05	110.3	340.3	0.0	-137.0
12.0	0.0	1.06E-04	-2.49E+03	-1.95E-04	115.8	469.0	0.0	-151.4
13.0	0.0	3.97E-05	-3.37E+03	-2.58E-04	121.1	616.4	0.0	-166.6
14.0	0.0	5.01E-05	-4.34E+03	-3.11E-04	126.2	779.1	0.0	-182.2
15.0	0.0	4.55E-05	-5.37E+03	-3.53E-04	127.1	944.4	0.0	-193.3
16.0	0.0	5.66E-05	-6.47E+03	-4.79E-04	125.7	1115.9	0.0	-201.8
17.0	0.0	6.79E-05	-7.63E+03	-5.95E-04	119.9	1292.2	0.0	-205.5
18.0	0.0	9.49E-05	-8.86E+03	-4.65E-04	109.8	1474.0	0.0	-204.4
19.0	0.0	1.68E-04	-1.02E+04	-5.72E-04	98.5	1666.9	0.0	-201.9
20.0	0.0	1.20E-04	-1.16E+04	-5.34E-04	82.6	1867.0	0.0	-194.3
21.0	0.0	1.33E-04	-1.31E+04	-6.10E-04	61.3	2073.1	0.0	-180.5
22.0	0.0	2.22E-03	-1.47E+04	7.63E-04	39.1	2291.4	0.0	-165.3
23.0	0.0	1.62E-04	-1.64E+04	-5.34E-04	10.6	2513.3	0.0	-142.9
24.0	0.0	1.46E-04	-1.81E+04	-8.39E-04	20.5	2743.4	0.0	-116.8

++> Offset range exceeded lateral interpolation table bounds.
First occurrence was in mooring line 7, offset value 14.00

***** Total Fairlead Line Tensions *****
(m.ton)

```

:
:
: Offset Type: Rectilinear Lateral Translation :
:
: Plan-View Offset Direction = 180.00 deg :
:
:
:
:

```

Line #:	1	2	3	4	5	6	7
Offset (m.)	.00	15.60	15.60	15.60	15.60	15.60	.55
1.00	17.78	16.69	14.75	14.01	14.75	16.69	5.80
2.00	20.70	17.79	14.01	12.64	14.01	17.79	11.96
3.00	24.51	19.09	13.28	11.63	13.28	19.09	18.90
4.00	29.70	20.74	12.65	10.77	12.65	20.74	27.34
5.00	37.32	22.41	12.15	10.05	12.15	22.41	37.97
6.00	48.87	24.66	11.66	9.49	11.66	24.66	53.00
7.00	67.14	27.20	11.16	8.98	11.16	27.20	75.04
8.00	96.94	30.10	10.81	8.60	10.81	30.10	108.75
9.00	143.84	34.02	10.46	8.24	10.46	34.02	160.65
10.00	213.50	38.17	10.11	7.94	10.11	38.17	235.55
11.00	312.13	44.21	9.81	7.69	9.81	44.21	341.39
12.00	433.32	50.84	9.56	7.47	9.56	50.84	470.38
13.00	570.48	60.09	9.31	7.29	9.31	60.09	618.10
> 14.00	720.62	71.48	9.06	7.13	9.06	71.48	781.09
15.00	870.77	85.46	8.86	6.99	8.86	85.46	946.81
16.00	1020.91	105.22	8.68	6.87	8.68	105.22	1118.68
17.00	1171.03	129.36	8.50	6.77	8.50	129.36	1295.28
18.00	1321.14	158.65	8.32	6.69	8.32	158.65	1477.49
19.00	1471.22	198.30	8.18	6.63	8.18	198.30	1670.83
20.00	1621.27	244.44	8.05	6.58	8.05	244.44	1871.35
21.00	1771.28	296.02	7.91	6.58	7.91	296.02	2077.93
22.00	1921.25	358.67	7.79	6.58	7.79	358.68	2296.69
23.00	2071.16	424.37	7.68	6.58	7.68	424.37	2519.12
24.00	2221.01	497.18	7.58	6.58	7.58	497.18	2749.62

++> Offset range exceeded lateral interpolation table bounds.
First occurrence was in mooring line 7, offset value 14.00

***** Mooring Line Potential Energy *****
(ton-meter)

```

:-----:
:
: Offset Type: Rectilinear Lateral Translation :
:
: Plan-View Offset Direction = 180.00 deg :
:
:-----:

```

Line #:	1	2	3	4	5	6	7
Offset (m.)	.00	8.74E+01	8.74E+01	8.74E+01	8.74E+01	8.74E+01	0.00E-01
	1.00	9.70E+01	9.24E+01	8.27E+01	7.93E+01	8.27E+01	9.24E+01-6.59E+02
	2.00	1.10E+02	9.71E+01	7.93E+01	7.21E+01	7.93E+01	9.71E+01-1.86E+03
	3.00	1.26E+02	1.04E+02	7.57E+01	6.69E+01	7.57E+01	1.04E+02-2.60E+03
	4.00	1.47E+02	1.10E+02	7.22E+01	6.22E+01	7.22E+01	1.10E+02-3.62E+03
	5.00	1.73E+02	1.18E+02	6.97E+01	5.82E+01	6.97E+01	1.18E+02-5.02E+03
	6.00	2.10E+02	1.27E+02	6.70E+01	5.52E+01	6.70E+01	1.27E+02-6.97E+03
	7.00	2.61E+02	1.36E+02	6.43E+01	5.24E+01	6.43E+01	1.36E+02-9.66E+03
	8.00	3.35E+02	1.48E+02	6.24E+01	5.02E+01	6.24E+01	1.48E+02-1.34E+04
	9.00	4.47E+02	1.60E+02	6.05E+01	4.83E+01	6.05E+01	1.60E+02-2.61E+04
	10.00	6.17E+02	1.76E+02	5.85E+01	4.68E+01	5.85E+01	1.76E+02-3.64E+04
	11.00	8.72E+02	1.94E+02	5.69E+01	4.55E+01	5.69E+01	1.94E+02-5.10E+04
	12.00	1.24E+03	2.15E+02	5.55E+01	4.46E+01	5.55E+01	2.15E+02-7.20E+04
	13.00	1.73E+03	2.40E+02	5.41E+01	4.38E+01	5.41E+01	2.40E+02-1.02E+05
>	14.00	2.37E+03	2.71E+02	5.28E+01	4.33E+01	5.28E+01	2.71E+02-1.01E+05
	15.00	3.14E+03	3.09E+02	5.17E+01	4.31E+01	5.17E+01	3.09E+02-1.00E+05
	16.00	4.03E+03	3.55E+02	5.07E+01	4.29E+01	5.07E+01	3.55E+02-9.85E+04
	17.00	5.05E+03	4.13E+02	4.97E+01	4.30E+01	4.97E+01	4.13E+02-9.65E+04
	18.00	6.19E+03	4.85E+02	4.88E+01	4.32E+01	4.88E+01	4.85E+02-9.40E+04
	19.00	7.45E+03	5.77E+02	4.81E+01	4.35E+01	4.81E+01	5.77E+02-9.09E+04
	20.00	8.84E+03	6.90E+02	4.73E+01	4.39E+01	4.73E+01	6.90E+02-8.72E+04
	21.00	1.03E+04	8.31E+02	4.66E+01	4.43E+01	4.66E+01	8.31E+02-8.29E+04
	22.00	1.20E+04	1.00E+03	4.61E+01	4.48E+01	4.61E+01	1.00E+03-7.77E+04
	23.00	1.37E+04	1.21E+03	4.55E+01	4.53E+01	4.55E+01	1.21E+03-7.19E+04
	24.00	1.56E+04	1.45E+03	4.51E+01	4.59E+01	4.51E+01	1.45E+03-6.52E+04

++> Offset range exceeded lateral interpolation table bounds.
First occurrence was in mooring line 7, offset value 14.00

***** VIII. Continuous Equilibrium Under Specified Forcing *****

```

:-----:
:
: Offset Type: Specified Force; Continuous Static Equilibrium :
:
: Global-Relative Force Direction: (Gx,Gy,Gz) = (-1.00, .00, .00) :
:
: Force Application Point (Vx,Vy,Vz) = (.00, .00, 6.60) :
:
:-----:

```

Moments reported about Vessel coordinate
(Vx,Vy,Vz) = (0.000E-01, 0.000E-01, 0.000E-01)

>>> Table Notes:

For "continuous offset" sequences, the "Total Restoring Force" is defined as the component of *Net* mooring force along the instantaneous offset vector. The instantaneous offset vector is *not* in general parallel to the net force vector and may also differ in direction from one offset row to the next in a sequence.

---- Most Exposed Line Characteristics: Buoy Data ----

Offset Number	Line #	-- Fairlead Tensions --			Unstretched Suspended Length (m.)	Anchor Forces		Total Restoring Force (m.ton)
		Total (m.ton)	Horiz. (m.ton)	Vert. (m.ton)		Rel. to Bottom <Parallel> (m.ton)	<Perp.> (m.ton)	
1.0	1	15.60	9.02	-12.77	60.9	9.02	-0.00	1.431E-06
2.0	1	19.69	13.08	-14.82	70.4	13.08	-0.00	3.563E-01
3.0	1	25.12	18.47	-17.16	81.4	18.47	-0.00	2.852E-01
4.0	1	31.45	24.77	-19.53	92.7	24.77	-0.00	4.673E-01
5.0	1	38.51	31.78	-21.80	104.1	31.78	-0.00	6.443E-01
6.0	1	45.91	39.14	-24.16	114.6	39.14	-0.00	9.911E-01
7.0	1	53.42	46.62	-26.27	124.6	46.62	-0.00	1.376E+00
8.0	1	61.17	54.33	-28.29	134.3	54.33	-0.00	1.816E+00
9.0	1	69.08	62.21	-30.19	143.6	62.21	-0.00	2.362E+00
10.0	1	77.17	70.27	-32.20	152.4	70.27	-0.00	2.985E+00
11.0	1	84.99	78.05	-33.76	160.9	78.05	-0.00	3.698E+00
12.0	1	92.80	85.83	-35.48	168.6	85.83	-0.00	4.492E+00
13.0	1	100.66	93.67	-37.22	176.1	93.67	-0.00	5.348E+00
14.0	1	108.43	101.40	-38.70	183.4	101.40	-0.00	6.276E+00
15.0	1	116.10	109.04	-39.94	190.8	109.04	-0.00	7.288E+00
16.0	1	123.95	116.87	-41.50	197.4	116.87	-0.00	8.329E+00
17.0	1	131.81	124.70	-43.06	203.9	124.70	-0.00	9.423E+00
18.0	1	139.58	132.45	-44.46	210.3	132.45	-0.00	1.059E+01
19.0	1	147.27	140.11	-45.70	216.7	140.11	-0.00	1.181E+01
20.0	1	154.88	147.69	-46.78	223.0	147.69	-0.00	1.310E+01
21.0	1	162.57	155.36	-47.96	229.0	155.36	-0.00	1.438E+01
22.0	1	170.29	163.06	-49.37	234.6	163.06	-0.00	1.574E+01
23.0	1	177.80	170.55	-50.67	240.0	170.55	-0.00	1.714E+01
24.0	1	185.25	177.98	-51.86	245.3	177.98	-0.00	1.853E+01
25.0	1	192.62	185.32	-52.96	250.6	185.32	-0.00	1.999E+01

***** VIII. Continuous Equilibrium Under Specified Forcing *****

```

:-----:
: Offset Type: Specified Force; Continuous Static Equilibrium :
: Global-Relative Force Direction: (Gx,Gy,Gz) = (-1.00, .00, .00) :
: Force Application Point (Vx,Vy,Vz) = (.00, .00, 6.60) :
:-----:

```

Moments reported about Vessel coordinate
(Vx,Vy,Vz) = (0.000E-01, 0.000E-01, 0.000E-01)

----- Summary of Continuous Equilibrium Offsets -----
(Buoy Data)

Offset Number	Force (m.ton)	Moment (ton-meter)	C.G. Offset (m.)			Angular Offset (deg)		
			Gx	Gy	Gz	Pitch	Roll	Yaw
1	0.00E-01	0.00E-01	.000	.000	.000	-1.00	.00	.00
2	1.00E+01	0.00E-01	-1.664	0.000	-.008	-1.42	0.00	0.00
3	2.00E+01	0.00E-01	-3.084	0.000	-.008	-2.89	0.00	0.00
4	3.00E+01	0.00E-01	-4.196	0.000	-.012	-4.38	0.00	0.00
5	4.00E+01	0.00E-01	-5.088	0.000	-.009	-5.89	0.00	0.00
6	5.00E+01	0.00E-01	-5.728	0.000	-.008	-7.25	0.00	0.00
7	6.00E+01	0.00E-01	-6.258	0.000	-.001	-8.56	0.00	0.00
8	7.00E+01	0.00E-01	-6.698	0.000	.012	-9.81	0.00	0.00
9	8.00E+01	0.00E-01	-7.077	0.000	.029	-11.03	0.00	0.00
10	9.00E+01	0.00E-01	-7.381	0.000	.047	-12.13	0.00	0.00
11	1.00E+02	0.00E-01	-7.674	0.000	.070	-13.21	0.00	0.00
12	1.10E+02	0.00E-01	-7.902	0.000	.091	-14.15	0.00	0.00
13	1.20E+02	0.00E-01	-8.100	0.000	.114	-15.02	0.00	0.00
14	1.30E+02	0.00E-01	-8.295	0.000	.141	-15.89	0.00	0.00
15	1.40E+02	0.00E-01	-8.487	0.000	.173	-16.74	0.00	0.00
16	1.50E+02	0.00E-01	-8.636	0.000	.203	-17.48	0.00	0.00
17	1.60E+02	0.00E-01	-8.770	0.000	.234	-18.17	0.00	0.00
18	1.70E+02	0.00E-01	-8.903	0.000	.268	-18.85	0.00	0.00
19	1.80E+02	0.00E-01	-9.034	0.000	.304	-19.52	0.00	0.00
20	1.90E+02	0.00E-01	-9.163	0.000	.343	-20.17	0.00	0.00
21	2.00E+02	0.00E-01	-9.279	0.000	.382	-20.78	0.00	0.00
22	2.10E+02	0.00E-01	-9.373	0.000	.419	-21.30	0.00	0.00
23	2.20E+02	0.00E-01	-9.464	0.000	.456	-21.80	0.00	0.00
24	2.30E+02	0.00E-01	-9.555	0.000	.493	-22.29	0.00	0.00
25	2.40E+02	0.00E-01	-9.645	0.000	.532	-22.77	0.00	0.00

***** VIII. Continuous Equilibrium Under Specified Forcing *****

```

:-----:
: Offset Type: Specified Force; Continuous Static Equilibrium :
: Global-Relative Force Direction: (Gx,Gy,Gz) = (-1.00, .00, .00) :
: Force Application Point (Vx,Vy,Vz) = (.00, .00, 6.60) :
:-----:

```

Moments reported about Vessel coordinate
(Vx,Vy,Vz) = (0.000E-01, 0.000E-01, 0.000E-01)

----- Hawser Characteristics -----

>>> Line Number 7, Line Type 2, Unstretched Length: 52.00 m. <<<

Net Vessel Offset (m.)	Buoy Offset (m.)	-- Buoy-End Tensions --			Vessel Forces Rel. to Bottom		Total Restoring Force (m.ton)
		Total (m.ton)	Horiz. (m.ton)	Vert. (m.ton)	<Parallel> (m.ton)	<Perp.> (m.ton)	
.00	.00	.55	.00	-.55	.00	.55	0.000E-01
53.73	1.66	10.00	10.00	-.05	10.00	-2.42	1.000E+01
55.64	3.08	20.02	20.00	.91	20.00	-3.38	2.000E+01
57.17	4.20	30.06	30.00	1.88	30.00	-4.32	3.000E+01
58.46	5.09	40.10	40.00	2.82	40.00	-5.27	4.000E+01
59.49	5.73	50.14	50.00	3.75	50.00	-6.22	5.000E+01
60.41	6.26	60.18	60.00	4.69	60.00	-7.11	6.000E+01
61.23	6.70	70.22	70.00	5.57	70.00	-8.04	7.000E+01
61.99	7.08	80.26	80.00	6.49	80.00	-8.90	8.000E+01
62.66	7.38	90.30	90.00	7.34	90.00	-9.81	9.000E+01
63.32	7.67	100.34	100.00	8.20	100.00	-10.67	1.000E+02
63.91	7.90	110.37	110.00	9.07	110.00	-11.48	1.100E+02
64.45	8.10	120.41	120.00	9.89	120.00	-12.34	1.200E+02
64.99	8.30	130.44	130.00	10.71	130.00	-13.18	1.300E+02
65.53	8.49	140.47	140.00	11.50	140.00	-13.97	1.400E+02
66.02	8.64	150.50	150.00	12.28	150.00	-14.70	1.500E+02
66.48	8.77	160.53	160.00	13.04	160.00	-15.48	1.600E+02
66.93	8.90	170.56	170.00	13.79	170.00	-16.25	1.700E+02
67.37	9.03	180.59	180.00	14.50	180.00	-16.98	1.800E+02
67.82	9.16	190.61	190.00	15.21	190.00	-17.67	1.900E+02
68.25	9.28	200.64	200.00	15.88	200.00	-18.33	2.000E+02
68.66	9.37	210.66	210.00	16.56	210.00	-18.97	2.100E+02
69.04	9.46	220.68	220.00	17.22	220.00	-19.66	2.200E+02
69.41	9.56	230.70	230.00	17.86	230.00	-20.32	2.300E+02
69.78	9.64	240.72	240.00	18.49	240.00	-20.96	2.400E+02

***** VIII. Continuous Equilibrium Under Specified Forcing *****

```

:-----:
:      Offset Type: Specified Force; Continuous Static Equilibrium      :
:      :                                                                :
:      Global-Relative Force Direction: (Gx,Gy,Gz) = (-1.00,  .00,  .00) :
:      :                                                                :
:      Force Application Point (Vx,Vy,Vz) = (  .00,  .00,  6.60) :
:      :                                                                :
:-----:

```

Moments reported about Vessel coordinate
(Vx,Vy,Vz) = (0.000E-01, 0.000E-01, 0.000E-01)

---- Most Exposed Line Potential Energy: Buoy Data ----

Buoy Offset Number	Line #	-- Fairlead Tensions --			Unstretched Suspended Length (m.)	Line Potential Energy (ton-meter)	Total Buoy Potential Energy (ton-meter)
		Total (m.ton)	Horiz. (m.ton)	Vert. (m.ton)			
.0	1	15.60	9.02	-12.77	60.9	8.742E+01	5.245E+02
1.7	1	19.69	13.08	-14.82	70.4	1.075E+02	5.320E+02
3.1	1	25.12	18.47	-17.16	81.4	1.318E+02	5.545E+02
4.2	1	31.45	24.77	-19.53	92.7	1.577E+02	5.820E+02
5.1	1	38.51	31.78	-21.80	104.1	1.851E+02	6.142E+02
5.7	1	45.91	39.14	-24.16	114.6	2.105E+02	6.461E+02
6.3	1	53.42	46.62	-26.27	124.6	2.363E+02	6.786E+02
6.7	1	61.17	54.33	-28.29	134.3	2.616E+02	7.098E+02
7.1	1	69.08	62.21	-30.19	143.6	2.873E+02	7.414E+02
7.4	1	77.17	70.27	-32.20	152.4	3.115E+02	7.711E+02
7.7	1	84.99	78.05	-33.76	160.9	3.369E+02	8.034E+02
7.9	1	92.80	85.83	-35.48	168.6	3.599E+02	8.331E+02
8.1	1	100.66	93.67	-37.22	176.1	3.819E+02	8.614E+02
8.3	1	108.43	101.40	-38.70	183.4	4.052E+02	8.913E+02
8.5	1	116.10	109.04	-39.94	190.8	4.304E+02	9.240E+02
8.6	1	123.95	116.87	-41.50	197.4	4.521E+02	9.520E+02
8.8	1	131.81	124.70	-43.06	203.9	4.739E+02	9.798E+02
8.9	1	139.58	132.45	-44.46	210.3	4.953E+02	1.008E+03
9.0	1	147.27	140.11	-45.70	216.7	5.187E+02	1.037E+03
9.2	1	154.88	147.69	-46.78	223.0	5.437E+02	1.069E+03
9.3	1	162.57	155.36	-47.96	229.0	5.670E+02	1.099E+03
9.4	1	170.29	163.06	-49.37	234.6	5.872E+02	1.124E+03
9.5	1	177.80	170.55	-50.67	240.0	6.086E+02	1.151E+03
9.6	1	185.25	177.98	-51.86	245.3	6.301E+02	1.179E+03
9.6	1	192.62	185.32	-52.96	250.6	6.518E+02	1.206E+03

***** VIII. Continuous Equilibrium Under Specified Forcing *****

```

:-----:
:      Offset Type: Specified Force; Continuous Static Equilibrium      :
:      :                                                                :
:      Global-Relative Force Direction: (Gx,Gy,Gz) = (-1.00,  .00,  .00) :
:      :                                                                :
:      Force Application Point (Vx,Vy,Vz) = (  .00,  .00,  6.60) :
:      :                                                                :
:-----:

```

Moments reported about Vessel coordinate
(Vx,Vy,Vz) = (0.000E-01, 0.000E-01, 0.000E-01)

----- Hawser Energy Characteristics -----

>>> Line Number 7, Line Type 2, Unstretched Length: 52.00 m. <<<

Net Vessel Offset (m.)	Buoy Offset (m.)	-- Buoy-End Tensions --			Hawser Potential Energy -----	Buoy Potential Energy (ton-meter)	System Potential Energy -----
		Total (m.ton)	Horiz. (m.ton)	Vert. (m.ton)			
.00	.00	.55	.00	-.55	0.000E-01	5.245E+02	5.245E+02
52.07	1.66	10.00	10.00	-.05	2.660E+01	5.320E+02	5.586E+02
52.55	3.08	20.02	20.00	.91	3.277E+01	5.545E+02	5.872E+02
52.97	4.20	30.06	30.00	1.88	4.105E+01	5.820E+02	6.230E+02
53.37	5.09	40.10	40.00	2.82	5.303E+01	6.142E+02	6.672E+02
53.77	5.73	50.14	50.00	3.75	7.021E+01	6.461E+02	7.163E+02
54.16	6.26	60.18	60.00	4.69	9.624E+01	6.786E+02	7.748E+02
54.54	6.70	70.22	70.00	5.57	1.098E+02	7.098E+02	8.196E+02
54.91	7.08	80.26	80.00	6.49	1.271E+02	7.414E+02	8.685E+02
55.28	7.38	90.30	90.00	7.34	1.680E+02	7.711E+02	9.392E+02
55.64	7.67	100.34	100.00	8.20	1.879E+02	8.034E+02	9.913E+02
56.01	7.90	110.37	110.00	9.07	2.114E+02	8.331E+02	1.044E+03
56.35	8.10	120.41	120.00	9.89	2.767E+02	8.614E+02	1.138E+03
56.70	8.30	130.44	130.00	10.71	3.005E+02	8.913E+02	1.192E+03
57.04	8.49	140.47	140.00	11.50	3.278E+02	9.240E+02	1.252E+03
57.38	8.64	150.50	150.00	12.28	3.585E+02	9.520E+02	1.310E+03
57.71	8.77	160.53	160.00	13.04	4.646E+02	9.798E+02	1.444E+03
58.02	8.90	170.56	170.00	13.79	4.926E+02	1.008E+03	1.500E+03
58.34	9.03	180.59	180.00	14.50	5.238E+02	1.037E+03	1.561E+03
58.66	9.16	190.61	190.00	15.21	5.581E+02	1.069E+03	1.627E+03
58.97	9.28	200.64	200.00	15.88	5.956E+02	1.099E+03	1.694E+03
59.29	9.37	210.66	210.00	16.56	7.734E+02	1.124E+03	1.898E+03
59.57	9.46	220.68	220.00	17.22	8.043E+02	1.151E+03	1.956E+03
59.85	9.56	230.70	230.00	17.86	8.380E+02	1.179E+03	2.017E+03
60.14	9.64	240.72	240.00	18.49	8.745E+02	1.206E+03	2.081E+03

***** VIII. Continuous Equilibrium Under Specified Forcing *****

```

:-----:
:      Offset Type: Specified Force; Continuous Static Equilibrium      :
:-----:
: Global-Relative Force Direction: (Gx,Gy,Gz) = (-1.00, .00, .00)      :
:-----:
: Force Application Point (Vx,Vy,Vz) = ( .00, .00, 6.60)              :
:-----:

```

Moments reported about Vessel coordinate
(Vx,Vy,Vz) = (0.000E-01, 0.000E-01, 0.000E-01)

Total Restoring Characteristics
and Cross-Coupling Summary

>>> Buoy Data <<<

Offset Number	Total Restoring Force				Induced Moments				Vessel-Relative Forces				
	(m.ton)				(m.ton*m.)				(m.ton)				
	Roll	Pitch	Yaw	Orthogonal	Surge	Sway	Heave						
1.0	0.0	0.00E-01	0.00E-01	2.11E-05	77.2	0.0	0.0	-76.6					
2.0	.4	-5.12E-06	-2.33E+01	8.11E-06	77.7	8.1	.0	-77.9					
3.0	.3	1.42E-04	-4.80E+01	-4.77E-06	78.6	15.9	0.0	-80.4					
4.0	.5	-2.06E-04	-7.41E+01	7.44E-05	80.3	23.4	0.0	-84.2					
5.0	.6	3.15E-04	-1.02E+02	5.05E-05	81.7	30.6	0.0	-88.1					
6.0	1.0	-7.14E-05	-1.28E+02	9.54E-06	83.8	37.7	0.0	-93.1					
7.0	1.4	3.20E-04	-1.55E+02	-3.81E-06	85.6	44.5	0.0	-98.0					
8.0	1.8	2.62E-04	-1.82E+02	3.81E-06	87.0	51.2	0.0	-102.9					
9.0	2.4	3.10E-04	-2.10E+02	0.00E-01	88.5	57.7	0.0	-108.0					
10.0	3.0	-3.08E-05	-2.36E+02	9.54E-06	90.0	64.1	0.0	-113.3					
11.0	3.7	-2.07E-05	-2.64E+02	5.72E-05	91.2	70.2	0.0	-118.6					
12.0	4.5	6.76E-04	-2.90E+02	-1.18E-04	92.8	76.4	0.0	-124.2					
13.0	5.3	-4.62E-05	-3.16E+02	3.81E-05	94.3	82.5	0.0	-129.9					
14.0	6.3	6.81E-04	-3.42E+02	-1.18E-04	95.5	88.4	0.0	-135.5					
15.0	7.3	-7.17E-05	-3.69E+02	-2.67E-05	96.6	94.1	0.0	-141.0					
16.0	8.3	2.89E-04	-3.95E+02	-5.34E-05	97.9	99.9	0.0	-146.7					
17.0	9.4	-5.14E-05	-4.20E+02	4.58E-05	99.1	105.7	0.0	-152.4					
18.0	10.6	-7.18E-05	-4.46E+02	-3.81E-06	100.2	111.3	0.0	-158.1					
19.0	11.8	-1.07E-04	-4.73E+02	3.81E-06	101.1	116.8	0.0	-163.6					
20.0	13.1	-3.63E-05	-5.00E+02	1.60E-04	102.0	122.3	0.0	-169.2					
21.0	14.4	-7.13E-04	-5.26E+02	2.56E-04	102.9	127.7	0.0	-174.8					
22.0	15.7	-7.18E-04	-5.51E+02	7.25E-05	104.0	133.2	0.0	-180.5					
23.0	17.1	1.11E-03	-5.77E+02	-8.01E-05	105.3	138.5	0.0	-186.3					
24.0	18.5	3.48E-05	-6.02E+02	-1.64E-04	106.5	143.8	0.0	-192.2					
25.0	20.0	8.84E-04	-6.28E+02	-3.62E-04	107.7	149.1	0.0	-198.1					

***** Total Fairlead Line Tensions *****
(m.ton)

```

:-----:
:      Offset Type: Specified Force; Continuous Static Equilibrium      :
:-----:
: Global-Relative Force Direction: (Gx,Gy,Gz) = (-1.00, .00, .00)      :
:-----:
: Force Application Point (Vx,Vy,Vz) = ( .00, .00, 6.60)              :
:-----:

```

Line #:	1	2	3	4	5	6	7
Offset Number							
1.00	15.60	15.60	15.60	15.60	15.60	15.60	.55
2.00	19.69	17.46	14.21	12.93	14.21	17.46	10.00
3.00	25.12	19.33	13.12	11.37	13.12	19.33	20.02
4.00	31.45	21.21	12.43	10.40	12.43	21.21	30.06
5.00	38.51	22.75	11.95	9.70	11.95	22.75	40.10
6.00	45.91	24.27	11.59	9.31	11.59	24.27	50.14
7.00	53.42	25.68	11.30	8.98	11.30	25.68	60.18
8.00	61.17	26.88	11.07	8.72	11.07	26.88	70.22
9.00	69.08	27.93	10.91	8.53	10.91	27.93	80.26
10.00	77.17	28.78	10.80	8.39	10.80	28.78	90.30
11.00	84.99	29.79	10.69	8.25	10.69	29.79	100.34
12.00	92.80	30.79	10.61	8.14	10.61	30.79	110.37
13.00	100.66	31.68	10.55	8.05	10.55	31.68	120.41
14.00	108.43	32.57	10.48	7.96	10.48	32.57	130.44
15.00	116.10	33.45	10.43	7.90	10.43	33.45	140.47
16.00	123.95	34.16	10.39	7.85	10.39	34.16	150.50
17.00	131.81	34.81	10.35	7.80	10.35	34.81	160.53
18.00	139.58	35.46	10.32	7.76	10.32	35.46	170.56
19.00	147.27	36.10	10.30	7.72	10.30	36.10	180.59
20.00	154.88	36.75	10.27	7.69	10.27	36.75	190.61
21.00	162.57	37.34	10.25	7.66	10.25	37.34	200.64
22.00	170.29	37.83	10.24	7.63	10.24	37.83	210.66
23.00	177.80	38.48	10.23	7.61	10.23	38.48	220.68
24.00	185.25	39.20	10.22	7.59	10.22	39.20	230.70
25.00	192.62	39.91	10.21	7.57	10.21	39.91	240.72

***** Mooring Line Potential Energy *****
(ton-meter)

.....
:
: Offset Type: Specified Force; Continuous Static Equilibrium :
:
: Global-Relative Force Direction: (Gx,Gy,Gz) = (-1.00, .00, .00) :
:
: Force Application Point (Vx,Vy,Vz) = (.00, .00, 6.60) :
:
:.....

Line #: 1 2 3 4 5 6 7

Offset
Number

1.00	8.74E+01	8.74E+01	8.74E+01	8.74E+01	8.74E+01	8.74E+01	0.00E-01
2.00	1.08E+02	9.63E+01	7.96E+01	7.27E+01	7.96E+01	9.63E+01	2.66E+01
3.00	1.32E+02	1.06E+02	7.37E+01	6.33E+01	7.37E+01	1.06E+02	3.28E+01
4.00	1.58E+02	1.15E+02	6.91E+01	5.69E+01	6.91E+01	1.15E+02	4.10E+01
5.00	1.85E+02	1.22E+02	6.63E+01	5.21E+01	6.63E+01	1.22E+02	5.30E+01
6.00	2.10E+02	1.29E+02	6.40E+01	4.90E+01	6.40E+01	1.29E+02	7.02E+01
7.00	2.36E+02	1.36E+02	6.21E+01	4.65E+01	6.21E+01	1.36E+02	9.62E+01
8.00	2.62E+02	1.41E+02	6.06E+01	4.44E+01	6.06E+01	1.41E+02	1.10E+02
9.00	2.87E+02	1.46E+02	5.93E+01	4.27E+01	5.93E+01	1.46E+02	1.27E+02
10.00	3.11E+02	1.51E+02	5.84E+01	4.13E+01	5.84E+01	1.51E+02	1.68E+02
11.00	3.37E+02	1.56E+02	5.75E+01	4.01E+01	5.75E+01	1.56E+02	1.88E+02
12.00	3.60E+02	1.60E+02	5.69E+01	3.91E+01	5.69E+01	1.60E+02	2.11E+02
13.00	3.82E+02	1.64E+02	5.65E+01	3.83E+01	5.65E+01	1.64E+02	2.77E+02
14.00	4.05E+02	1.68E+02	5.61E+01	3.75E+01	5.61E+01	1.68E+02	3.01E+02
15.00	4.30E+02	1.73E+02	5.58E+01	3.68E+01	5.58E+01	1.73E+02	3.28E+02
16.00	4.52E+02	1.76E+02	5.55E+01	3.63E+01	5.55E+01	1.76E+02	3.59E+02
17.00	4.74E+02	1.80E+02	5.54E+01	3.58E+01	5.54E+01	1.80E+02	4.65E+02
18.00	4.95E+02	1.83E+02	5.52E+01	3.54E+01	5.52E+01	1.83E+02	4.93E+02
19.00	5.19E+02	1.87E+02	5.51E+01	3.51E+01	5.51E+01	1.87E+02	5.24E+02
20.00	5.44E+02	1.90E+02	5.51E+01	3.47E+01	5.51E+01	1.90E+02	5.58E+02
21.00	5.67E+02	1.93E+02	5.51E+01	3.45E+01	5.51E+01	1.93E+02	5.96E+02
22.00	5.87E+02	1.96E+02	5.51E+01	3.43E+01	5.51E+01	1.96E+02	7.73E+02
23.00	6.09E+02	1.99E+02	5.51E+01	3.41E+01	5.51E+01	1.99E+02	8.04E+02
24.00	6.30E+02	2.02E+02	5.52E+01	3.40E+01	5.52E+01	2.02E+02	8.38E+02
25.00	6.52E+02	2.05E+02	5.53E+01	3.38E+01	5.53E+01	2.05E+02	8.75E+02

Index

A

acceleration.....	45
added mass	17, 44, 50
anchor.....	2, 12-15, 17, 19, 32, 38-39, 49-50
anchor depths.....	2, 12-15, 19, 49
archival.....	4, 51
ASCII.....	17-19, 52
asymmetric.....	45
asymmetry.....	31, 41
Auto Repeat.....	44

B

backup.....	5, 11, 36
backup file.....	5
baseline.....	44
beam.....	29, 46-47
benchmark.....	0
binary.....	4, 51
bottom friction.....	12, 14, 38, 49
bow.....	16, 31
breaking strength.....	13, 17-20, 22, 50
Brydon.....	21
buoy.....	1-3, 6-9, 14-15, 18, 27, 33, 35, 41-42, 47-50, 57
buoyancy.....	7-8
buoys.....	7-8, 13, 15

C

cables.....	18
CALMDAT.....	2, 6-7, 12, 35, 48
calmdat.....	2, 6-7, 12, 35, 48
CALMsim.....	2, 6-7, 9, 14, 33, 35, 47-48
carriage return.....	9-10, 12, 45
CATDAT.....	2, 4-6, 51-52, 56
CATIN.....	4, 51
CATOUT.....	4, 38
center of buoyancy.....	29, 44
center of gravity.....	29, 31, 34, 43-44
centroid.....	16, 25, 28, 34-35, 42, 44, 46
chain.....	17-21, 48, 50
clockwise.....	24, 55
clump.....	1, 7-8, 15
coefficient.....	12, 14, 17, 21-22, 49-50
column.....	39, 41
comma.....	54, 56
composite.....	9, 48, 58
continuous equilibrium.....	2, 6, 26-30, 35, 40-43
coordinate.....	24-26, 33-34, 44
coordinate system.....	16, 24, 26-28, 30-31, 42, 44, 46
Copy.....	6, 17, 36-37, 50-51
correction.....	18
couple.....	26, 30
cross-coupling.....	33-34, 41
cross-reference.....	5, 9

Index

cubic	11, 19, 21-23
D	
damping	45
data file	6-7, 9, 11, 20, 36-37, 48-49, 51-53, 55-56
debug	33, 35
declination	13, 32
default values	34
delete	17-18, 50
density	11, 23, 29
depth	12, 14-15, 17, 19, 45, 47, 49-50
diameter	8, 17-20, 48, 50
dimensionless	19
disk file	51
displacement	14, 18, 29, 45, 47
docks	15, 19
draft	7, 12, 14, 25, 29, 35, 45, 47-49
drag coefficient	7-8, 17, 50
E	
earth	44
earth-fixed	16, 24, 27, 30, 33-34
elastic	17-20, 50, 52-53
element	1, 12, 15, 31, 38-39, 49
elongation	19-22, 53-54
energy	33-34
English	9, 11
English units	44-45
environment	1, 16, 36
environmental conditions	4, 6
environmental forces	44
equilibrium	1-2, 6, 14, 26-32, 34-35, 39-43, 45
equilibrium configuration	45
equilibrium position	39-40
error	15, 36-37
exponential	44
export	7
F	
fairlead	2, 6-7, 13-20, 27-28, 32-35, 38-39, 42, 47, 49
fairlead-anchor	32
fairlead-attached	20
fitting	22
floating point	9, 44-45, 56
flow	10
force couple	26, 30-31
formatted	4
formatted data file	51
formatted output	4
Fortran	44
freeboard	45
frequency-domain	0
freshwater	20

Index

G

global	16, 24-28, 30-33, 48, 55
global coordinate	26
global coordinate system	16, 24, 27, 30
global coordinates	44
gravitational	34, 45
gyradius	44

H

hawser.....	2-3, 7, 9, 12, 14, 27, 35, 41-42, 47-50
heading	15-16, 24, 49
heave.....	29, 41, 45
heel	12, 14
height-dependent	20
help facility.....	20
hydrostatic	1, 6, 27, 29, 35, 40, 43
hydrostatic characteristics	29
hydrostatic data	7, 48

I

import	7, 33, 35-37, 48
in-plane.....	44
inertia.....	18, 44
input data	5-6, 36, 44, 47, 51, 57-58
input data file.....	4
insert.....	17, 50
integral.....	4
integration.....	29
interface	4, 6, 9, 12
internal.....	5, 18-19, 32
IWRC	19

K

keel	14, 16, 44-47
Kevlar.....	21-22
kilogram	44
kip.....	44
KML.....	29, 44, 47
KMT	29, 44, 47

L

LASTBAK	4-5, 36
lateral	1, 14, 23, 25, 28, 34, 40-43
lateral offset.....	2, 6, 23-24, 40, 42
legs	7, 12-15, 35, 48-49
line load	13, 18, 38, 40, 47
linear.....	19, 22, 24, 38, 53
LOA.....	45
loaded	2, 40
local	5, 20, 53
lower case.....	10
lowercase	12
LPP.....	45
Lpp	45

Index

M

machine-readable	4, 45
mass properties.....	7
maximum number	18
maximum value	13, 15, 18
MEANOUT.....	4, 31, 39
member.....	1
metacenter	44
metacentric	29
meter.....	11, 17, 50
metric.....	9, 11-12, 17, 19, 22, 30, 44-45, 47-50
metric units.....	45
model test.....	0
MOORDAT.....	6, 37
MOORED.....	7, 14, 26, 45
MOORIN.....	37

N

natural period.....	45
nonzero.....	12-14, 16, 22, 34, 39, 42, 49, 55
Nylon.....	19, 21, 48, 50
Nystron.....	19, 21

O

oblique.....	1, 23-26, 28, 33-34, 40-43, 52, 55
OFFSETDAT	42
OFFSETS	1-4, 14, 23-27, 29-31, 33-34, 38, 40-43, 55-56
orientation.....	27, 31
orthogonal.....	34, 41
orthogonal to offset	41
oscillate.....	45
output file	38-40
output options.....	6-7, 31-32, 40, 48
overlay	4, 9

P

parallel.....	23, 42-43
perpendicular	23
pitch.....	14, 25, 27-29, 34, 41, 43, 45
pitch moment.....	29
plan-view	14-16, 24, 31-33, 35, 39, 46, 49
polyester	19, 21
Polypropylene.....	19, 21
potential energy	33-34
precision	33, 35
pretension	13-14, 20, 32, 39, 48
program file	4
prompts.....	11, 17-18

Q

quasi-static.....	1, 13, 45
quiescent.....	15, 31, 35, 39, 49

Index

R

reflect.....	14
regular.....	36, 44, 48
regular wave period.....	10
restoring.....	2, 40-43, 45
right-hand.....	14, 26, 28, 41, 55
rope.....	19, 21-22
rotate.....	35
rotation.....	2, 23, 25-26, 42, 55
rotational.....	1, 24-26, 40-42, 55

S

scale.....	45
screen image.....	36
semi-automatic input.....	10
SEMIDAT.....	37
SEMISIM.....	37
semisubmersible.....	37
sequential.....	10
Shipsim.....	29
sign convention.....	39
Simulator.....	4
site.....	3-4, 11, 51
site data.....	11
sloping bottom.....	2, 19
spiral.....	21
SPMDAT.....	2, 6
SPMIN.....	37
spread-moor.....	35
spreadsheet.....	23
square-law.....	7-8
stability.....	26
stress-strain.....	21-23
stud-link.....	21
subline.....	8, 13-15, 17-20, 38-39, 50, 53-54
subscreen.....	9-10, 14-15, 20
surface-resident.....	15
surge.....	41
sway.....	41
symmetric.....	34-35
symmetrical.....	35
symmetry.....	34
synthetic.....	21
synthetic material.....	18

T

tangent.....	39
tanker.....	6-7, 9, 12, 27, 33, 35, 42, 47-50
taut-wire.....	20
tension-elongation.....	19, 22, 53-54
tension-leg.....	20
thruster.....	30
tlpsim.....	2
toggle.....	7, 9, 14-15, 19, 28, 30-32, 34-35, 39, 45, 48

Index

ton.....17, 29, 44-45, 50
torque.....42
torquing 40-41, 43
trim 12, 14
troubleshooting.....36
tugboat27, 30
turret33, 35

U
unformatted data file51
units4, 7, 9, 11, 22, 34
user-defined52
user-input.....20
user-specified 21, 30, 32, 34, 38-39, 43, 53-55
user-supplied19, 21, 31, 52

V
vector 25, 27-28, 41, 55-56
vertical..... 1, 6-7, 13-14, 20, 23-26, 28-30, 32, 34-35, 38-40, 42-44, 46
vessel coordinates..... 14
Vessel Data.....37
vessel-fixed..... 27, 30, 41, 46
VKB29, 47
VKG29, 47

W
water density11
water depth..... 11, 13, 47
water plane29, 47
waterline12, 15, 29, 34, 45-46, 49
waterplane 1-2, 23-26, 28-30, 40-43, 46
waterplane coefficient46
weight.....1, 7-8, 13-14, 17-20, 29, 42, 44-45, 50

X
x-axis25, 27, 46
x-coordinate.....30

Y
y-axis25, 28, 46
y-coordinate.....30
yaw1, 23, 25, 31, 34, 40-43
yaw offset.....23-24, 30, 42

Z
z-axis46